

2011 Eco-lution

High Performance Air-Conditioning



HyperMulti
KX·KXR

VRF inverter multi-system Air-Conditioners

CE

50Hz

11KX04E-A-0



ecolution

History of Technologies

more efficient , more sophisticated



New Line Up



MicroKX

KX·KXR6

Contents

Introduction	4~13
Outdoor units	14~45
Indoor units	46~77
Control systems	78~82
Service and maintenance	83
High Head series	84~87
KX4 Outdoor units	88 · 89
Further information	90~93



Product Line Up

<Outdoor units>

from 11.2kW up to 136.0kW(24models)

Single use (1 Outdoor unit)												
Capacity	4HP	5HP	6HP	8HP	10HP	12HP	14HP	16HP	18HP	20HP	22HP	24HP
Model Index : kW	11.2	14	15.5	22.4	28	33.5	40.0	45.0	50.4	56.0	61.5	68.0
BTU / h	38,200	47,800	52,900	76,400	95,500	114,300	136,500	153,600	172,000	191,100	209,900	232,000
kcal / h	9,630	12,040	13,330	19,260	24,080	28,810	34,400	38,700	43,340	48,160	52,890	58,480

Combination use (2 Outdoor units)												
Capacity	26HP	28HP	30HP	32HP	34HP	36HP	38HP	40HP	42HP	44HP	46HP	48HP
Model Index : kW	73.5	80.0	85.0	90.0	96.0	101.0	106.5	113.0	118.0	123.5	130.0	136.0
BTU / h	250,800	273,000	290,100	307,100	327,600	344,700	363,400	385,600	402,700	421,400	443,600	464,100
kcal / h	63,210	68,800	73,100	77,400	82,560	86,860	91,590	97,180	101,480	106,210	111,800	116,960

MicroKX



4HP	5HP	6HP
FDC112KXEN6	FDC140KXEN6	FDC155KXEN6
FDC112KXES6	FDC140KXES6	FDC155KXES6

- 1-phase
- 3-phase



MicroKX

8HP	10HP	12HP
FDC224KXE6	FDC280KXE6	FDC335KXE6



KX6

12HP	14HP	16HP	18HP
FDC335KXE6-K*	FDC400KXE6	FDC450KXE6	FDC504KXE6

20HP	20HP	22HP	24HP
FDC560KXE6	FDC560KXE6-K*	FDC615KXE6	FDC680KXE6



KX6

26HP	28HP	30HP	32HP	34HP	36HP
FDC735KXE6	FDC800KXE6	FDC850KXE6	FDC900KXE6	FDC960KXE6	FDC1010KXE6
12+14	14+14	14+16	16+16	16+18	18+18
FDC335KXE6-K FDC400KXE6	FDC400KXE6 FDC400KXE6	FDC400KXE6 FDC450KXE6	FDC450KXE6 FDC450KXE6	FDC450KXE6 FDC504KXE6	FDC504KXE6 FDC504KXE6

38HP	40HP	42HP	44HP	46HP	48HP
FDC1065KXE6	FDC1130KXE6	FDC1180KXE6	FDC1235KXE6	FDC1300KXE6	FDC1360KXE6
18+20	20+20	20+22	22+22	22+24	24+24
FDC504KXE6 FDC560KXE6	FDC560KXE6 FDC560KXE6	FDC560KXE6-K FDC615KXE6	FDC615KXE6 FDC615KXE6	FDC615KXE6 FDC680KXE6	FDC680KXE6 FDC680KXE6

* FDC335KXE6-K & FDC560KXE6-K are only used for combining with other models.

<Indoor units>

Wide variety of 17 types 83 models

A range of 17 types of exposed or concealed indoor units, in wide capacities, 83 indoor models. The best selection of indoor units for many kinds of rooms and preference can be available from our full lineup.



Indoor units lineup

Type			Capacity	0.8HP	1HP	1.25HP	1.6HP	2HP	2.5HP	3.2HP	4HP	5HP	6HP	8HP	10HP
			Model Index : kW	22	28	36	45	56	71	90	112	140	160	224	280
Ceiling Cassette	4way	FDT			●	●	●	●	●	●	●	●	●		
	4way Compact (600 x 600)	FDTc		●	●	●	●	●							
	2way	FDTW			●		●	●	●	●	●	●			
	1way Compact	FDTQ		●	●	●									
	1way	FDTs					●		●						
Duct Connected	High Static Pressure	FDU							●	●	●	●		●	●
	Low/Middle Static Pressure	FDUM		●	●	●	●	●	●	●	●	●			
	Low Static Pressure (thin)	FDUT		●	●	●	●	●							
	Compact & Flexible	FDUH		●	●	●									
Wall Mounted		FDK		●	●	●	●	●							
Ceiling Suspended		FDE				●	●	●	●		●	●			
Floor Standing	2way	FDfW			●		●	●							
	with casing	FDfL							●						
	without casing	FDfU			●		●	●	●						
Type			Air flow M³/h	250	350	500	800	850	1000	1300	1800				
Fresh Air Ventilation and Heat Exchange unit		SAF		●	●	●	●		●						
Fresh Air DX Assembly		SAF-DX		●	●	●	●		●						
OA Processing unit		FDU-F				●		●		●		●		●	



1. High Efficiency (KX6)

The industry's highest COP levels

We have cleared the class A standard, the highest energy saving level, with our high COP (Coefficient Of Performance).

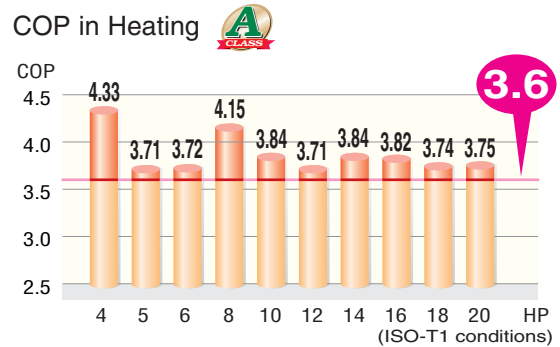
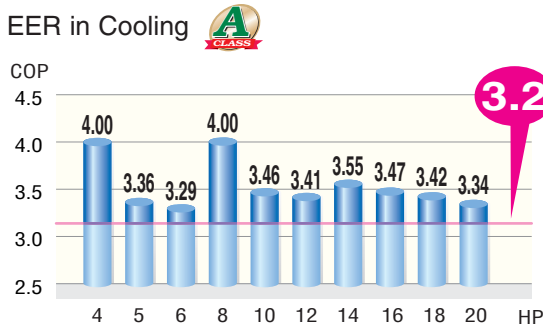

* COP = Capacity[kW] / Power Consumption[kW]

* COP across the KX6 range ensures reduced running costs and reduced environmental impact.

2. Compact Design

4~6HP(KX6)



Previous Model
H1300 x W970 x D370mm
125kg / 0.47m³

Volume

35% reduced

Weight

32% reduced



1FAN

New Model
H845 x W970 x D370mm
85kg / 0.30m³
(FDC112/140/155KXEN6)

- Transportation Becomes much easier
- Easier to hide behind the fence (Harmonic Appearance)

8~12HP(KX6)



Previous Model
H1690 x W1350 x D720mm
245kg / 0.97m³

Volume

47% reduced

Weight

10% reduced



2FAN

New Model
H1675 x W1080 x D480mm
221kg / 0.52m³ (FDC224KXE6)

- Transportation Becomes much easier

High efficiency and compact design are realized applying the various advanced functions

4~6HP(KX6)

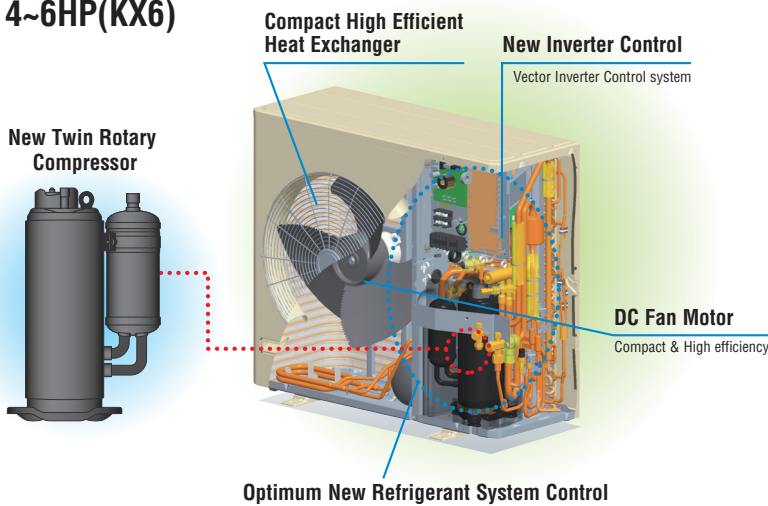

Compact high efficiency Heat Exchanger

- Optimizing relationship of the air flow velocity & fin pattern
- Improvement of air distribution Maximizing efficiency of heat exchanger

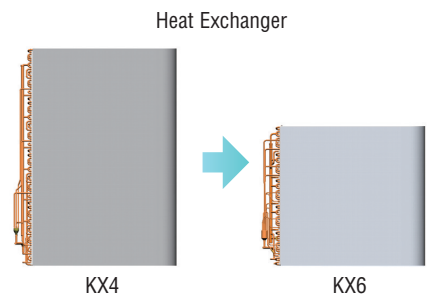

8~12HP(KX6)

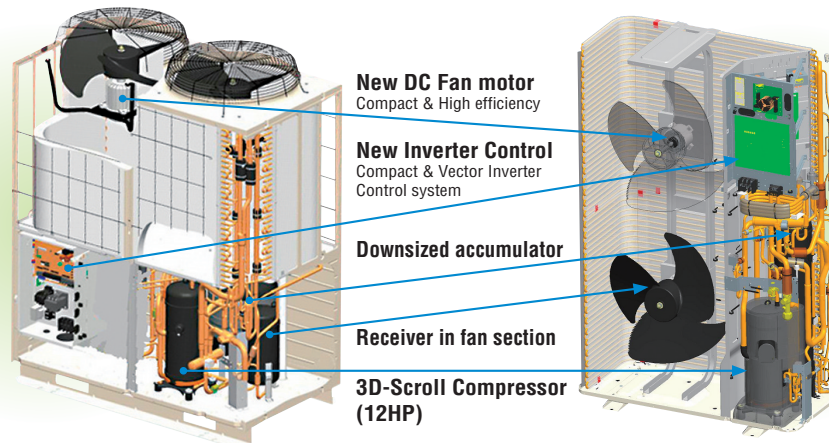

14~48HP(KX6)

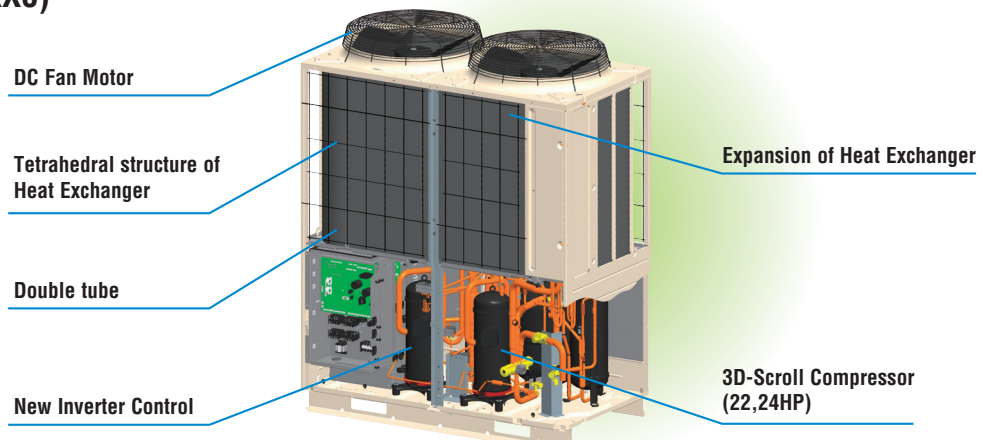



3D Scroll Compressor

Unit start up speed in heating mode drastically improved for lower outdoor temperature operation.



Downsizing

High Efficiency **High Endurance**

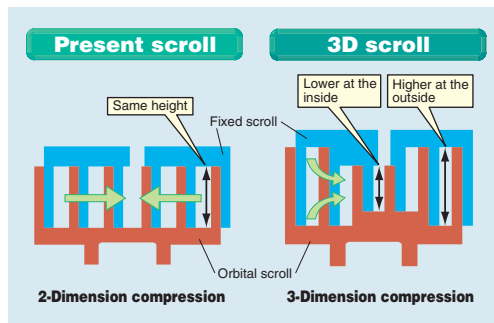

3D scroll compressor has the different height scroll at the outside and the inside.
 A high compression ratio is improved by compressing the refrigerant both radially and axially.
 3-Dimension Compression has been realized with a much higher efficiency even if compression ratio is high.

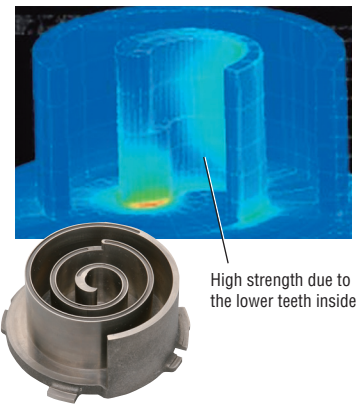

The strength of the scroll is improved by reducing the height of the inner wrap, which receives a heavy load.

* 3D compressors are applied for 12HP, 20HP, 22HP & 24HP.

New Inverter Control (Vector control)

New Inverter Control has applied new advanced technology of Vector control and has realized high efficiency.

- Smooth operation from low speed to high speed
- Smooth Sine Voltage Wave form are attained
- Energy efficiency is further improved in low speed range

Compact Integrated PCB

- Control Box size reduction
- PCB size reduced by 50 %
 Control PCB: Single-sided board → Double-sided board
 Inverter PCB: Power transistor size reduction
- New Superlink system control
- New Design method applied

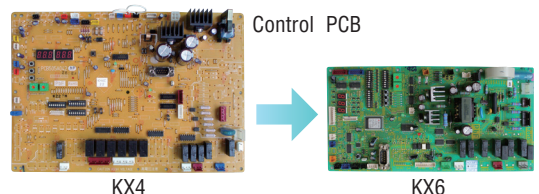

Optimum Refrigerant System Control

We have improved refrigeration circuit from our long experience and have realized following Optimum Refrigerant System Control.

- Optimum heat exchanger refrigerant distribution
- Advanced refrigerant liquid return protection control system
- High speed system control by new Superlink system
- Use of larger diameter for suction piping and discharge piping and redesigned of double tube

DC Fan Motor

Employment of DC fan motor has enabled to realize an excellent efficiency of approximate 60% higher than previous models.

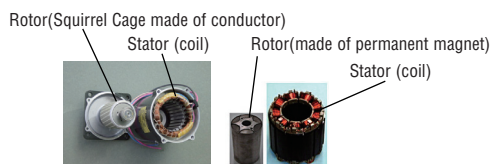

Long-chorded 3 propeller fan with serration

Fan blade design adapted from MHI's aerospace division - with serrated edges that deliver increased air volume with less power input.

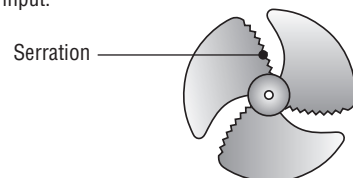

3. Design Flexibility

Increased indoor unit connection capacity

KX6 series(4~34HP) can connect indoor unit capacity up to 150~200% from 130% of previous models.
 If the connection capacity of indoor units is more than 100%, capacity of each indoor unit may be affected by connection capacity ratio.

Capacity connection

HP	KX4, KXR4	HP	KX6	HP	KXR6
5~12	130%	4~12	150%	8~16	200%
14,16	130%	14,16	200%	18~34	160%
18~34	130%	18~34	160%	36~48	130%
36~48	130%	36~48	130%		

- In case that capacity connection is more than 130%, additional charge of refrigerant is required on site.
- In case of 8-34HP of KX6/KXR6 system, if one or more indoor units of FDK, FDFL, FDFU and/or FDFW series are connected to the system, the total connecting capacity of indoor units should not exceed 130%.

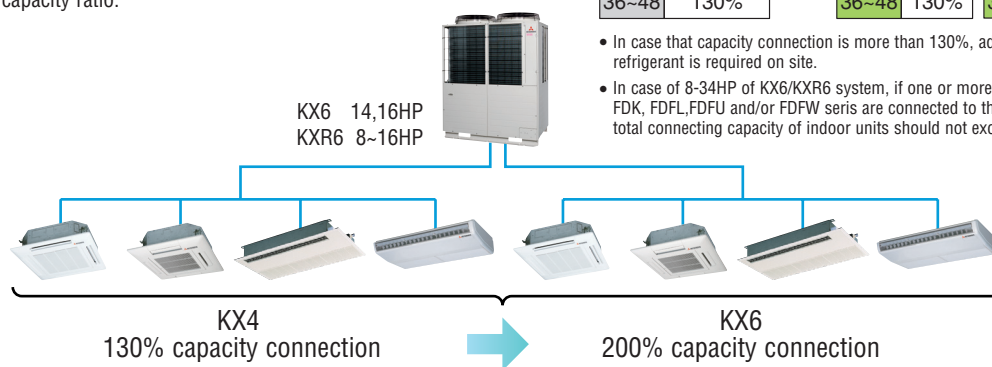

More connectable indoor units

KX6 enable more connectable indoor units (per kW), compared with former model KX4.

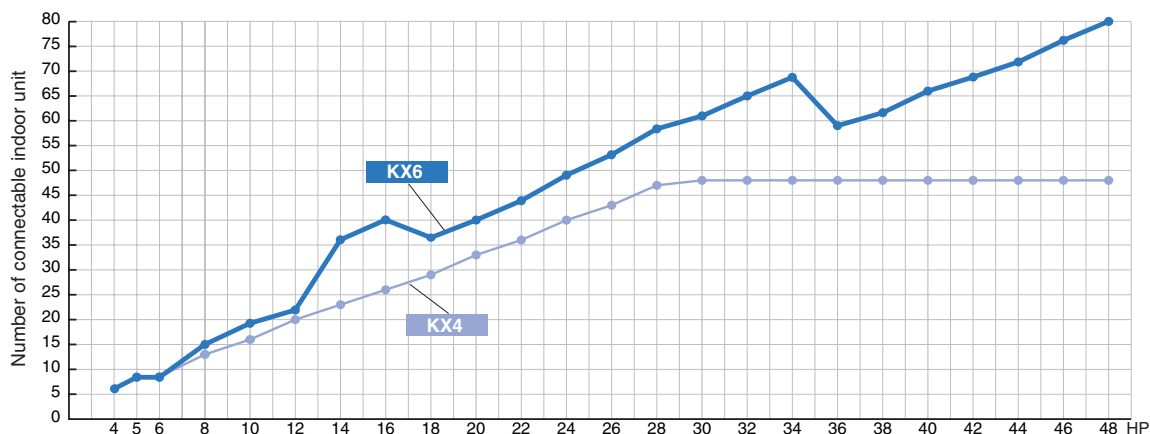

Control Systems

KX6 series offer wide variation of control system and provide the best solution.

[KX6, KXR6 Control system units with "New" SUPERLINK- II]

Classification	Type	Model	Connectable indoor units (Maximum)	Electric power calculation
Individual controller	Wired	RC-E4	1	—
	Wireless	RCN-T-36W-E etc.	1	—
Center Console	Push buttons	SC-SL1N-E	16	—
		SC-SL2NA-E	64	—
	Touch screen	SC-SL3NA-AE	128	—
		SC-SL3NA-BE	128	●
	PC windows interface units	SC-WGWNA-A	128(64x2)	—
		SC-WGWNA-B	128(64x2)	●
BMS interface units	BACnet	SC-BGWNA-A	128(64x2)	—
		SC-BGWNA-B	128(64x2)	●
	Lonworks	SC-LGWNA-A	96(48x2)	—



Long Pipe Length

Piping length has extended max height difference between indoor units from 4m to 18m and enables us to put indoor unit on extra three floors.

As a result of the adoption of thinner refrigerant piping and refrigerant volume reductions, the industry's longest 160 m actual piping length or 1000m total piping length is realized.

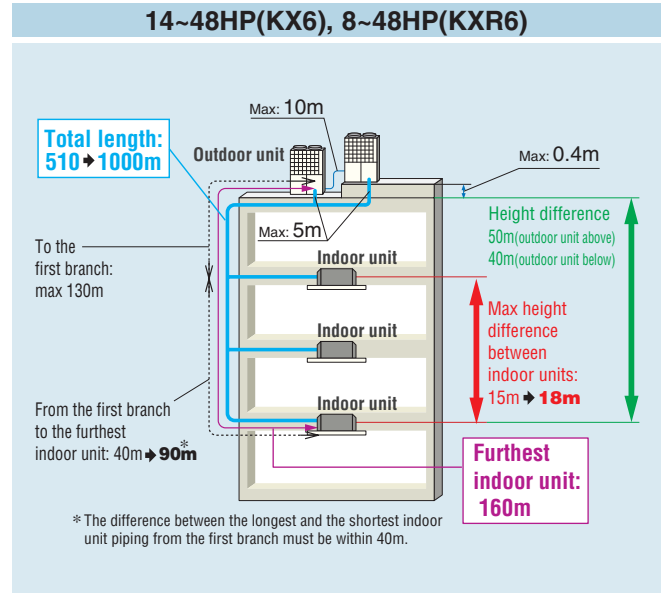
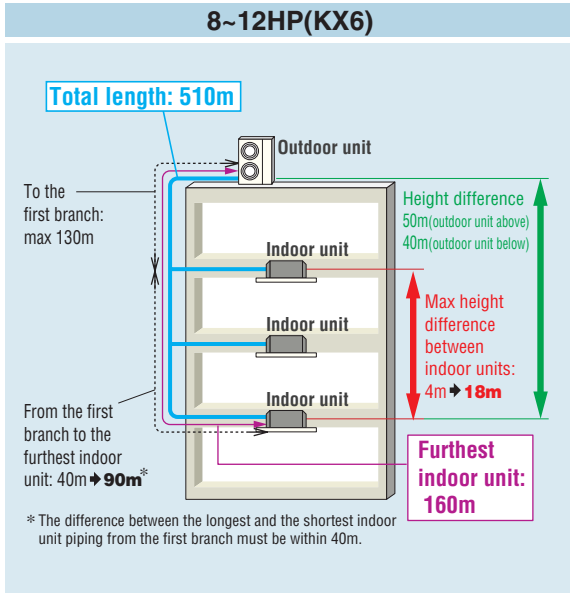

- (1) Divide up the refrigerant system into independent refrigeration circuit systems in case required additional refrigerant on site is 50kg or more for 14~24HP and 100kg or more for 26~48HP.
- (2) In case indoor unit connection capacity is 130% or more or total piping length is 510m or more, additional charge of refrigerant and oil on site is required. Refer to our Installation Manual for details.

Easy Transportation & Installation

Due to realization of significant reduction in size and foot print which is one of the smallest in the industry, transportation in an elevator made for six persons (Width:1400mm, Depth:850, Open area:800mm) is possible, eliminating cost of a crane and reducing labor.

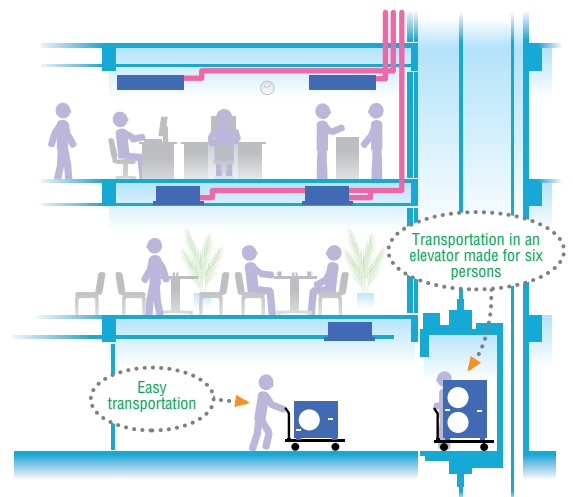
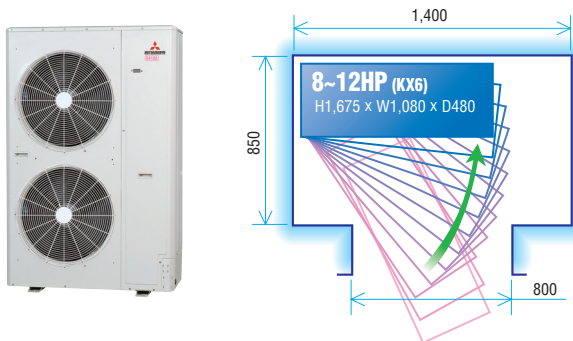

KX6(14~48HP) is portable and the uniform reduced footprint allows neat, continuous installation.

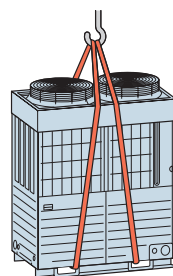

Wide Range of Operation

KX6, KXR6 series permits a system design considering a heating range operation under a low temperature condition up to -20°C from -15°C of previous model and a cooling range operation under -15°C from -5°C of that.

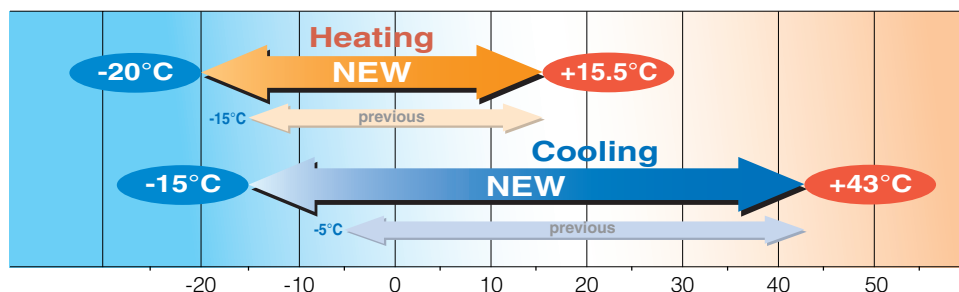

* For the capacities under low temperature conditions, refer to technical manual.

New remote control for all indoor units

Applying nonpolar 2-core in new remote control line, it is very convenient for installation including renewal case.

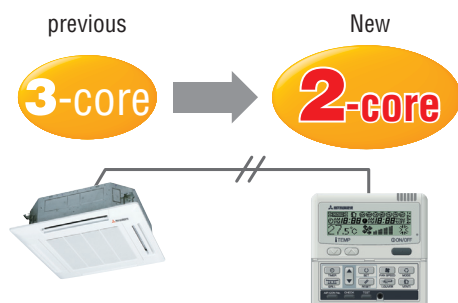

Max length of electrical wiring

The wiring must be a 2-core shielded cable size 0.75mm^2 to 1.25mm^2 .

The max length of 2-core can be 1500m from 1000m of previous models.



4. Serviceability

Easy Service

Quick and easy access to service parts by separation of compartments.

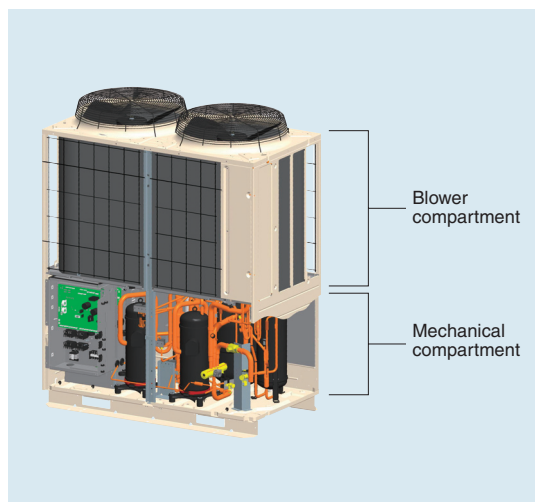

Check Operation (8~48HP)

Closing of Service valve, crossing connection of refrigerant piping and electrical wiring, proper operation of EEV (Electrical Expansion Valve) can be checked automatically in cooling operation. This check operation can be done at $0\sim 43^{\circ}\text{C}$ outdoor temperature and $10\sim 32^{\circ}\text{C}$ indoor temperature by use of outdoor unit dip switch. The check should be done in one refrigerant system. It takes 15~30 minutes and avoids frequent failure by preventing careless mistakes during installation.

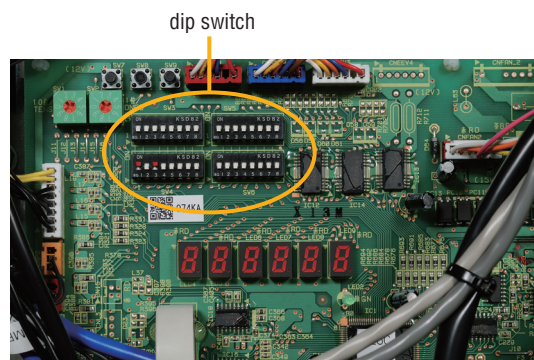



Monitoring Function

KX6 series includes new feature to assist with servicing and trouble shooting. Various data can be monitored through 3-digit or 6-digit display on the outdoor unit PCB.

Detailed fault diagnosis and operation history memory via 7-segment display.

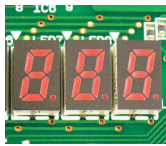

4~6HP

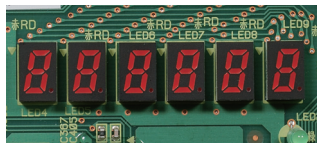

8~48HP

Equipped with RS232C for connection directly to your PC monitoring and service tasks made simple with our service software ("Mente PC").
all KX6, KXR6 series

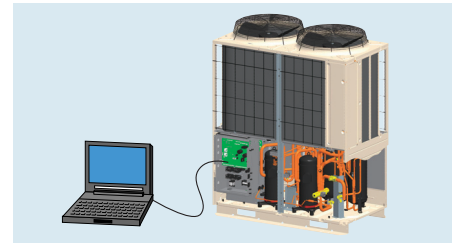

3 Layer Construction (KX6 <14~48HP>, KXR6 <8~48HP>)

Thanks to improvement of control box structure from 4 to 3 layer construction and by use of hinged lays, service and maintenance has been made much easier for inverter components.



Back-up Operation <14~48HP>

In, 2-compressor module, in the event of the compressor failure, the system will keep operating with good compressor. In combined module, in the event that one unit has a failure, the system will keep operating with another unit.

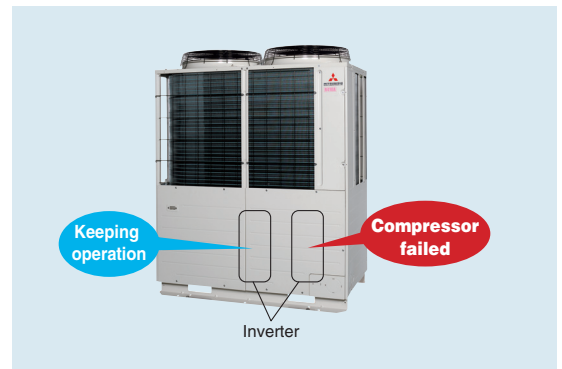

Reduced Refrigerant Volume

To use the new refrigerant R410A, KX6 series have adopted thinner diameter refrigerant pipes, which will help reduce piping work cost.

KX6 R410A

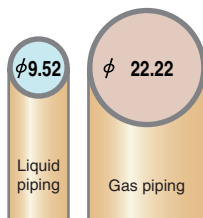

ex. 10HP

Outdoor unit

HP	KX6	
	Liquid piping	Gas piping
4	ø9.52	ø15.88
5		
6		
8		
10		
12	ø12.7	ø25.4[ø28.58]
14		
16		
18		
20	ø15.88	ø28.58
22		
24		
26		
28		
30		
32		
34		
36	ø19.05	ø31.8[ø34.92]
38		
40		
42		
44	ø19.05	ø38.1[ø34.92]
46		
48		
48		

[]: Pipe sizes applicable to European installations are shown in parentheses.

mm	ø9.52	ø12.7	ø15.88	ø19.05	ø22.22	ø25.4	ø28.58	ø31.8	ø34.92	ø38.1	ø44.5	ø50.8
inch	3/8"	1/2"	5/8"	3/4"	7/8"	1"	1 1/8"	1 1/4"	1 3/8"	1 1/2"	1 3/4"	2"

Blue Fin

Due to application of blue coated fins for the heat exchanger of new outdoor unit, corrosion resistance has been improved compared to current models.



KX6 heat pump systems

KX6 heat pump systems operate with 2 inter-connecting pipes, thus commonly referred to as a '2-pipe system'.

These systems provide either a heating or cooling operation to all indoor units and are suitable for a wide range of applications from an individual apartment (with "Micro KX", 1/phase system) to an entire multi storey building, especially where there are significant open plan areas to be controlled.

The range starts with a 11.2kW cooling capacity, up to the largest capacity single outdoor unit in the industry (24hp) with 68.0kW cooling capacity. Outdoor units can also be "twinned" providing up to 48HP/136.0kW on a single system.

The KX6 range has a total piping length of 1000m (14HP+) and the furthest indoor unit can be connected up to 160m (8HP+) from the outdoor unit.

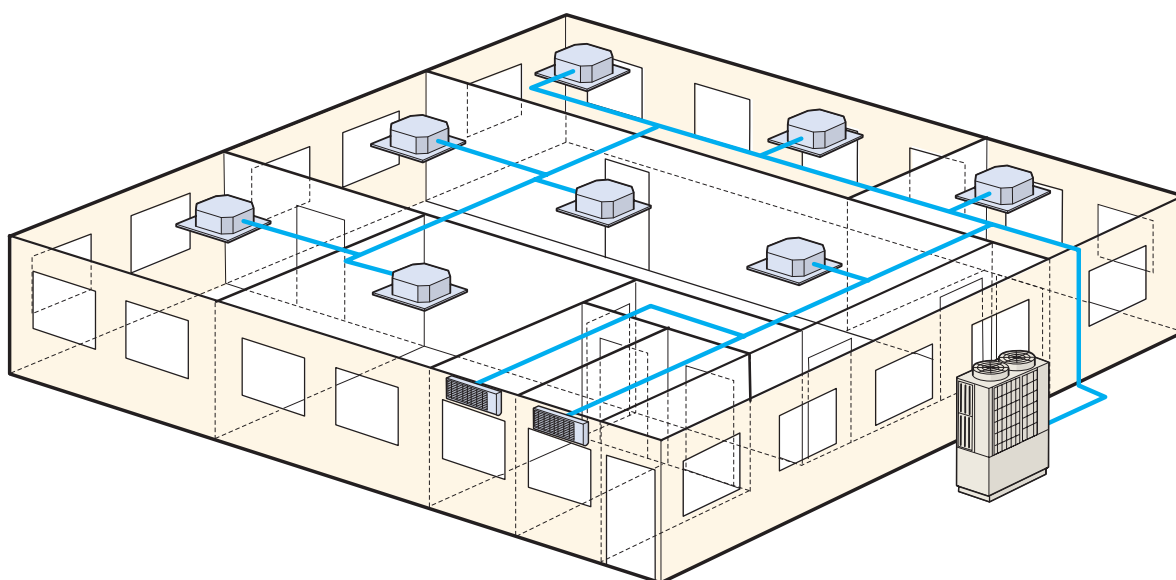

Fixed Cooling mode/fixed heating mode (summer/winter switch):

It is possible to fix the operational mode of the system (either cooling or heating) using a switch (SW3-7) on the outdoor unit PC board - this enables the building user to decide the operation of the system (e.g. cooling only in summer/heating only in winter), to avoid unnecessary energy wastage. It is also possible to wire the control switch to a remote location (inside the building) to a control room, or even linked to an ambient thermostat.





MicrOKX Outdoor units

Heat pump systems 4, 5, 6hp (11.2kW~15.5kW)

Model No.	Nominal Cooling Capacity
FDC112KXEN6	11.2kW (1phase)
FDC140KXEN6	14.0kW (1phase)
FDC155KXEN6	15.5kW (1phase)
FDC112KXES6	11.2kW (3phase)
FDC140KXES6	14.0kW (3phase)
FDC155KXES6	15.5kW (3phase)

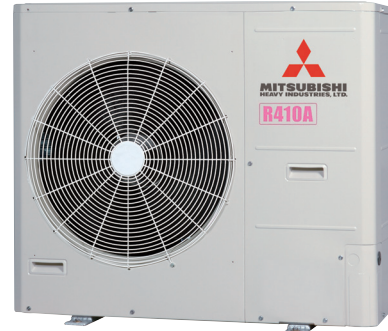

- The KX6 heat pump 2-pipe systems offer high performance VRF for applications that require either cooling only or heating only, ideal for open plan areas.
- Connect up to 8 indoor units/up to 150% capacity.
- High efficiency with COP (in cooling) up to 4.0.
- KX6 employs DC inverter compressors ONLY.
- Industry leading total piping length up to 100m and a maximum pipe run of 70m.

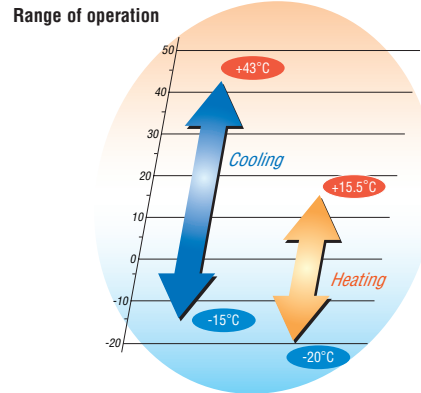
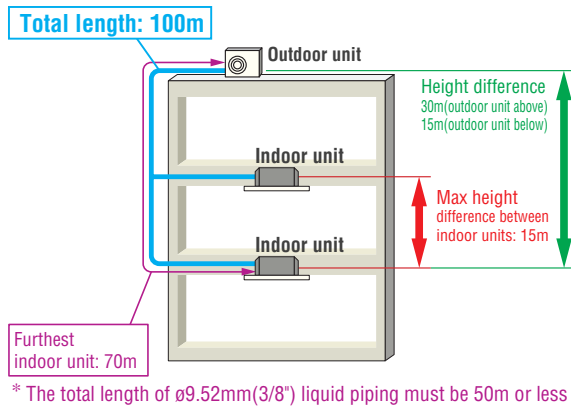

Specifications

Item	Model	FDC112KXEN6	FDC140KXEN6	FDC155KXEN6	FDC112KXES6	FDC140KXES6	FDC155KXES6		
Nominal horse power		4HP	5HP	6HP	4HP	5HP	6HP		
Power source		1 Phase 220-240V, 50Hz			3 Phase 380-415V, 50Hz				
Nominal capacity	Cooling	11.2	14.0	15.5	11.2	14.0	15.5		
	Heating	12.5	16.0	16.3	12.5	16.0	16.3		
Electrical characteristics	Starting current	A						5	
	Power consumption	Cooling	2.80	4.17	4.71	2.80	4.17	4.71	
		Heating	2.89	4.31	4.38	2.89	4.31	4.38	
	Running current	Cooling	13.5-12.4	20.6-18.9	23.3-21.3	4.5-4.1	6.9-6.3	7.8-7.1	
Heating		14.1-12.9	21.5-19.7	21.9-20.1	4.7-4.3	7.2-6.6	7.3-6.7		
Exterior dimensions	HxWxD	mm						845x970x370	
Net weight		kg			85			87	
Refrigerant charge	R410A	kg			5.0				
Sound pressure level	Cooling/Heating	dB(A)		52/54	53/55	53/56	52/54	53/55	53/56
Refrigerant piping size	Liquid line	mm(in)						ø9.52(3/8")	
	Gas line	mm(in)						ø15.88(5/8")	
Capacity connection		%						80~150	
Number of connectable indoor units		6	8	8	6	8	8		

1. The data are measured under the following conditions(ISO-T1). Cooling: Indoor temp. of 27°CDB, 19°CWB, and outdoor temp. of 35°CDB. Heating: Indoor temp. of 20°CDB, and outdoor temp. of 7°CDB, 6°CWB. Piping length is 7.5m.
 2. Sound pressure level indicates the value in anechoic chamber. During operation these values are somewhat higher due to ambient conditions.

Refrigerant piping

Outdoor unit (HP)		4	5	6
Gas pipe	Furthest indoor unit ≈70m	ø15.88		
Liquid pipe		ø9.52		

Branch pipes

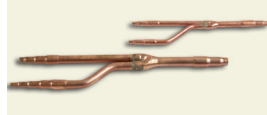

DIS-22-1/DIS-180-1

Header pipe



HEAD6-180-1

Dimensions

All measurements in mm.

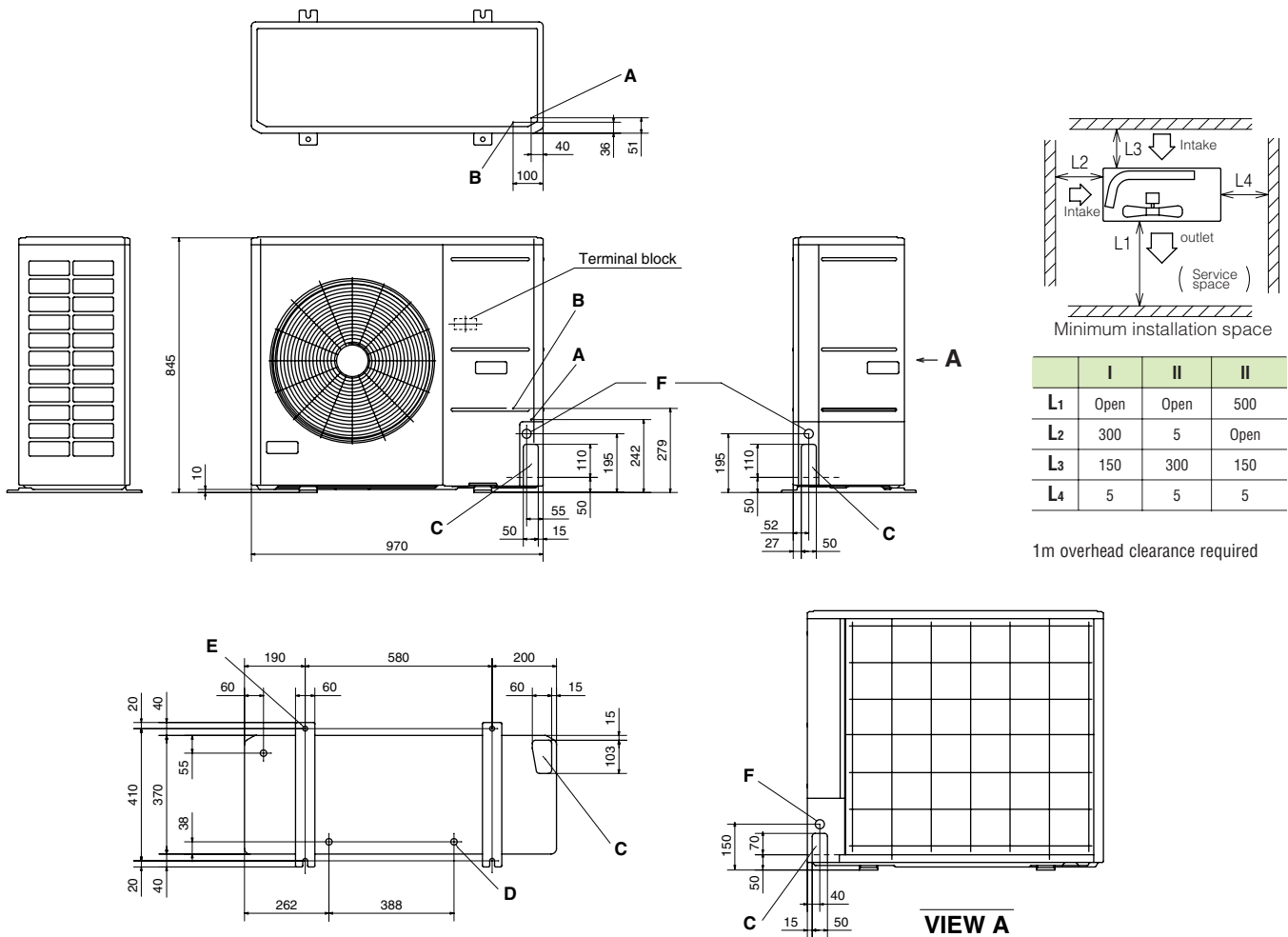

Mark	Item	
A	Service valve connection (gas side)	ø15.88 (5/8") (flare)
B	Service valve connection (liquid line)	ø9.52 (3/8") (flare)
C	Pipe/cable draw-out port	4 places
D	Drain discharge port	ø20 x 3 places
E	Anchor bolt hole	M10 x 4 places
F	Cable draw-out port	ø30 x 3 places

Notes:

- (1) It must not be surrounded by walls on the four sides.
- (2) The unit must be fixed with anchor bolts. An anchor bolt must not protrude more than 15mm.
- (3) Where the unit is subject to strong winds, lay it in such a direction that the blower outlet faces perpendicularly to the dominant wind direction.
- (4) Leave a 1m or larger space above the unit.
- (5) A wall in front of the blower outlet must not exceed the units height.
- (6) The unit name plate is attached on the lower right corner of the front panel.



MicroKX Outdoor units

Heat pump systems 8, 10, 12hp (22.4kW~33.5kW)

Model No.	Nominal Cooling Capacity
FDC224KXE6	22.4kW
FDC280KXE6	28.0kW
FDC335KXE6	33.5kW

- The KX6 heat pump 2-pipe systems offer high performance VRF for applications that require either cooling only or heating only, ideal for open plan areas.
- Connect up to 22 indoor units/up to 150% capacity.
- High efficiency with COP (in cooling) up to 4.0.
- KX6 employs DC inverter compressors ONLY.
- Industry leading total piping length up to 510m and a maximum pipe run of 160m.

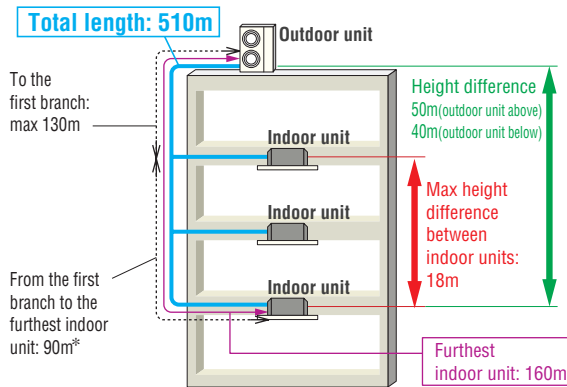

* The difference between the longest and the shortest indoor unit piping from the first branch must be within 40m.

Range of operation

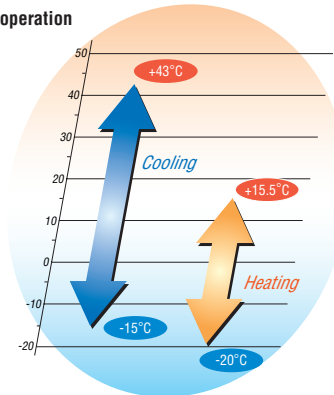

Specifications

Item	Model	FDC224KXE6	FDC280KXE6	FDC335KXE6		
Nominal horse power		8HP	10HP	12HP		
Power source		3 Phase 380-415V, 50Hz				
Nominal capacity	Cooling	kW	22.4	28.0	33.5	
	Heating		25.0	31.5	37.5	
Electrical characteristics	Starting current	A	5			
	Power consumption	Cooling	kW	5.60	8.09	9.82
		Heating		6.03	8.21	10.12
	Running current	Cooling	A	9.25-8.47	13.22-12.10	15.87-14.53
Heating			9.85-9.02	13.41-12.28	16.36-14.98	
Exterior dimensions	HxWxD	mm	1675x1080x480			
Net weight		kg	221			
Refrigerant charge	R410A	kg	11.5			
Sound pressure level	Cooling/Heating	dB(A)	58/58	59/60	61/61	
Refrigerant piping size	Liquid line	mm(in)	ø9.52(3/8")			
	Gas line		ø19.05(3/4")	ø22.22(7/8")	ø25.4(1") [ø28.58(1 1/8")]	
Capacity connection		%	50~150			
Number of connectable indoor units			15	19	22	

1. The data are measured under the following conditions(ISO-T1). Cooling: Indoor temp. of 27°CDB, 19°CWB, and outdoor temp. of 35°CDB. Heating: Indoor temp. of 20°CDB, and outdoor temp. of 7°CDB, 6°CWB. Piping length is 7.5m.
 2. Sound pressure level indicates the value in an anechoic chamber. During operation these values are somewhat higher due to ambient conditions.
 3. [] : Pipe sizes applicable to European installations are shown in parentheses.

Refrigerant piping

Outdoor unit (HP)		8	10	12
Gas pipe	Furthest indoor unit =<90m	ø19.05	ø22.22	ø28.58
Liquid pipe		ø9.52		ø12.7
Gas pipe	Furthest indoor unit =<90m	ø22.22		ø28.58
Liquid pipe		ø12.7		

Branch pipes

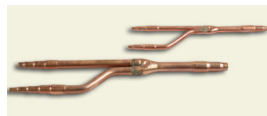

DIS-22-1/DIS-180-1

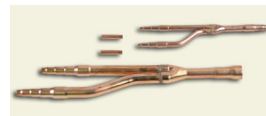

DIS-371-1

Header pipe



HEAD6-180-1

Dimensions

All measurements in mm.

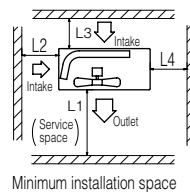
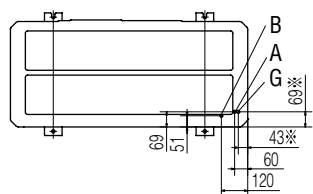

	I	II	III
L1	Open	Open	1500
L2	300	5	Open
L3	300	300	300
L4	5	5	5

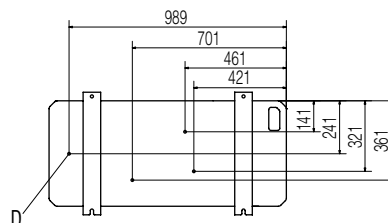
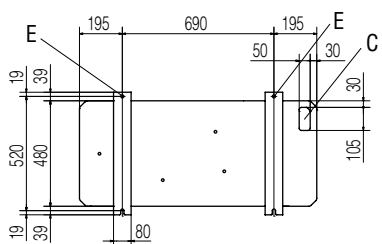
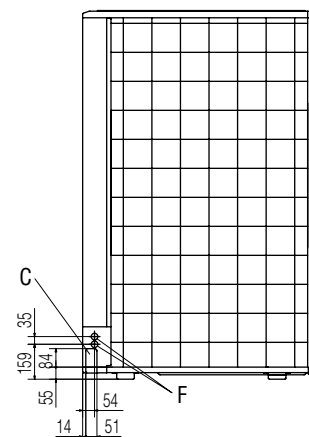
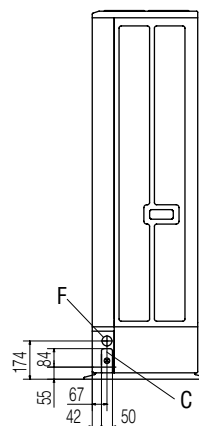
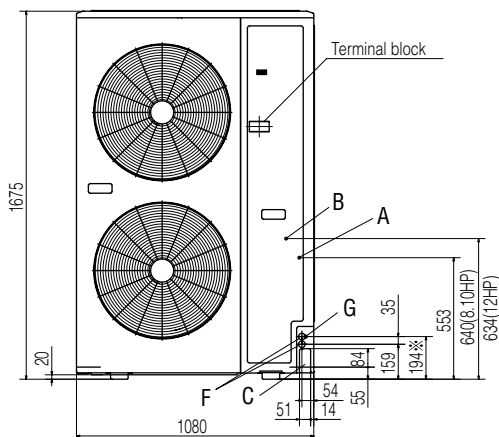
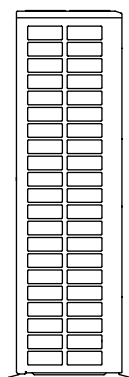

Mark	Item	FDC224KXE6	FDC280KXE6	FDC335KXE6
A	Service valve connection of the attached connecting pipe (gas side)	ø19.05 (3/4") (Flare)	ø19.05 (3/4") (Flare)	ø19.05 (3/4") (Flare)
B	Service valve connection (liquid side)	ø9.52 (3/8") (Flare)	ø9.52 (3/8") (Flare)	ø12.7 (1/2") (Flare)
C	Pipe/cable draw-out hole	4places	4places	4places
D	Drain discharge hole	ø20 × 4places	ø20 × 4places	ø20 × 4places
E	Anchor bolt hole	M10 × 4places	M10 × 4places	M10 × 4places
F	Cable draw-out hole	ø30 × 2places (front) ø45 (side) ø30 × 2places (back)	ø30 × 2places (front) ø45 (side) ø30 × 2places (back)	ø30 × 2places (front) ø45 (side) ø30 × 2places (back)
G	Connecting position of the local pipe. (gas side)	ø19.05 (3/4")(Brazing)	ø22.22 (7/8")(Brazing)	ø25.4 (1")(Brazing)

Notes:

- It must not be surrounded by walls on the four sides.
- The unit must be fixed with anchor bolts. An anchor bolt must not protrude more than 15mm.
- Where the unit is subject to strong winds, lay it in such a direction that the blower outlet faces perpendicularly to the dominant wind direction.
- Leave a 1m or larger space above the unit.
- A wall in front of the blower outlet must not exceed the units height.
- The model name label is attached on the lower right corner of the front.
- Connect the Service valve with local pipe by using the pipe of the attachment.(Gas side only)
- Mark ※ shows the connecting position of the local pipe.(Gas side only)



KX6 Outdoor units

Heat pump systems 14, 16hp (40.0kW~45.0kW)

Model No.	Nominal Cooling Capacity
FDC400KXE6	40.0kW
FDC450KXE6	45.0kW



Uniform footprint of models (14,16hp) allows continuous side-by-side installation

- The KX6 heat pump 2-pipe systems offer high performance VRF for applications that require either cooling only or heating only, ideal for open plan areas.
- Connect up to 40 indoor units/up to 200% capacity.
- High efficiency with COP (in cooling) up to 3.6.
- KX6 employs DC inverter compressors ONLY.
- Industry leading total piping length up to 1000m and a maximum pipe run of 160m.

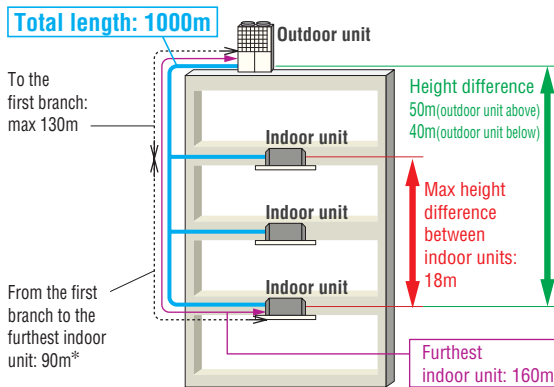

* The difference between the longest and the shortest indoor unit piping from the first branch must be within 40m.

Range of operation

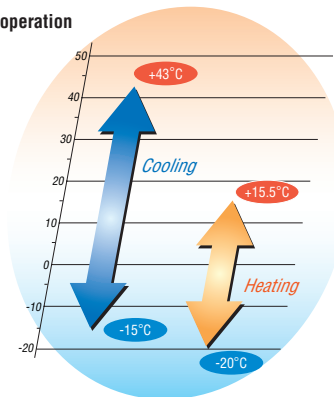

Specifications

Item		Model	FDC400KXE6	FDC450KXE6
Nominal horse power			14HP	16HP
Power source			3 Phase 380-415V, 50Hz	
Nominal capacity	Cooling	kW	40.0	45.0
	Heating	kW	45.0	50.0
Electrical characteristics	Starting current		8	
	Power consumption	Cooling	11.27	12.97
		Heating	11.73	13.10
	Running current	Cooling	18.4-16.9	21.1-19.3
Heating		19.6-17.9	21.7-19.9	
Exterior dimensions		HxWxD	1690x1350x720	
Net weight		kg	317	
Refrigerant charge		R410A	11.5	
Sound pressure level		Cooling/Heating	59.5/60	62.5/62.5
Refrigerant piping size	Liquid line	mm(in)	ø12.7(1/2")	
	Gas line	mm(in)	ø25.4(1") [ø28.58(1 1/8")]	
Capacity connection		%	50~200	
Number of connectable indoor units			36	40

1. The data are measured under the following conditions(ISO-T1). Cooling: Indoor temp. of 27°CDB, 19°CWB, and outdoor temp. of 35°CDB. Heating: Indoor temp. of 20°CDB, and outdoor temp. of 7°CDB, 6°CWB. Piping length is 7.5m.
 2. Sound pressure level indicates the value in an anechoic chamber. During operation these values are somewhat higher due to ambient conditions.
 3. [] : Pipe sizes applicable to European installations are shown in parentheses.

Dimensions

All measurements in mm.

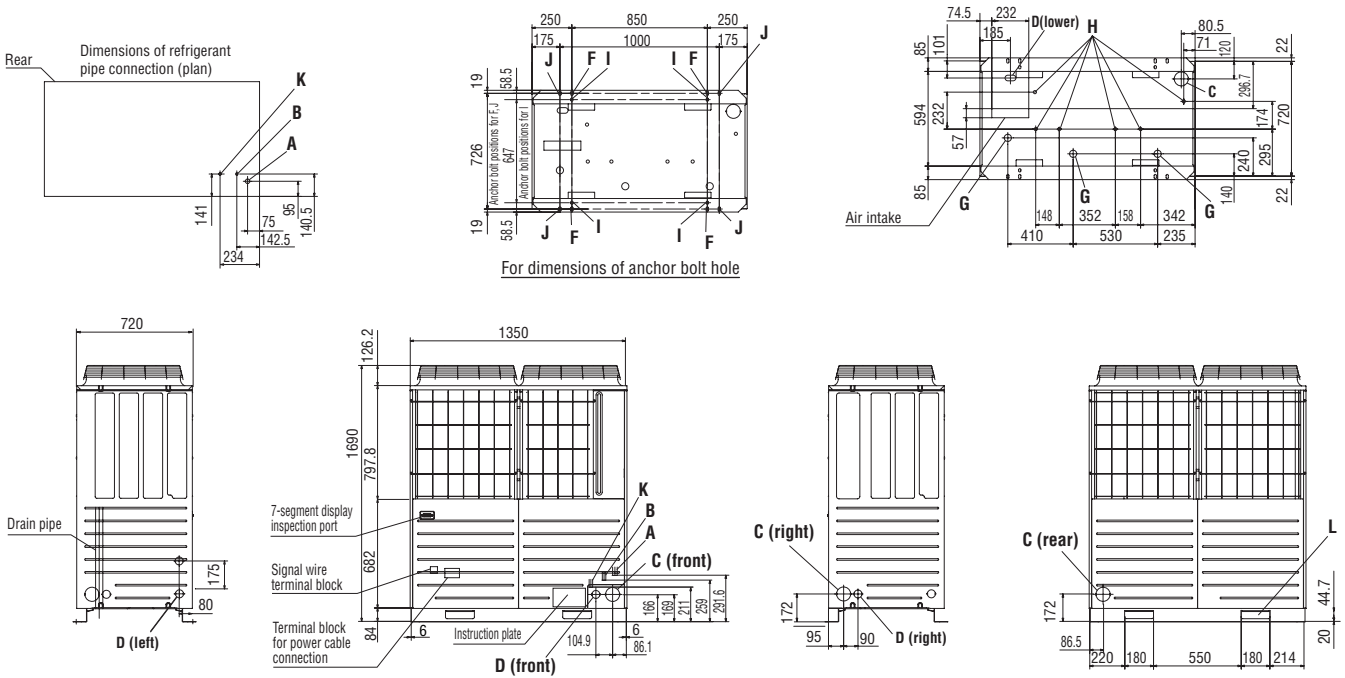

Mark	Item	
A	Service valve connection (gas side)	For refrigerant piping, please refer to the unit specifications.
B	Service valve connection (liquid line)	
C	Refrigerant pipe draw-out port	ø88
D	Power cable draw-in port	ø50
F	Anchor bolt hole	M10 x 4 places
G	Drain hose hole	ø45 x 3 places
H	Drain discharge port	ø20 x 6 places
K*	Oil-equalising pipe joint	ø3/8" flare
L	Sling holes for haulage or hoisting	180 x 44.7

*14, 16HP models only

Installation example		
Dimensions	1	2
L ₁	500	Open
L ₂	10	200
L ₃	100	300
L ₄	10	Open
H ₁	1500	-
H ₂	No restrictions	No restrictions
H ₃	1000	No restrictions
H ₄	No restrictions	-

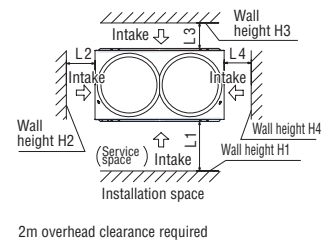

Notes:

- The unit must be fixed with anchor bolts.
- Leave a 2m or larger space above the unit.
- The unit name plate is attached on the lower right corner of the front panel.
- The ports for refrigerant pipe and power cable penetrations are covered with half-blanks. Please cut off a half-blank with nippers in using these ports.
- Use a ø88 port for refrigerant pipe connection.
- Anchor holes marked "L J" (four holes for M10) are for a renewal installation.
- The oil-equalising pipe K should be used when outdoor units are used in combination. (For 14,16Hp only)

When more than one unit is installed

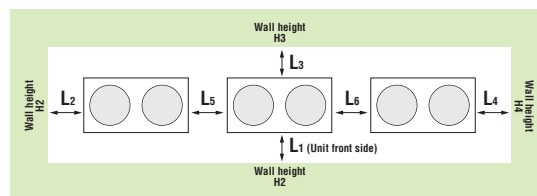

Installation example		
Dimensions	A	B
L ₁	500	Open
L ₂	10	200
L ₃	100	300
L ₄	10	Open
L ₅	0	400
L ₆	0	400
H ₁	1500	No restrictions
H ₂	No restrictions	No restrictions
H ₃	1000	No restrictions
H ₄	No restrictions	No restrictions



KX6 Outdoor units

Heat pump systems 18, 20, 22, 24hp (50.4kW~68.0kW)

Model No.	Nominal Cooling Capacity
FDC504KXE6	50.4kW
FDC560KXE6	56.0kW
FDC615KXE6	61.5kW
FDC680KXE6	68.0kW

- The KX6 heat pump 2-pipe systems offer high performance VRF for applications that require either cooling only or heating only, ideal for open plan areas.
- Connect up to 49 indoor units/up to 160% capacity.
- High efficiency with COP (in cooling) up to 3.4.
- KX6 employs DC inverter compressors ONLY.
- Industry leading total piping length up to 1000m and a maximum pipe run of 160m.



Uniform footprint of all models (from 8hp~24hp) allows continuous side-by-side installation

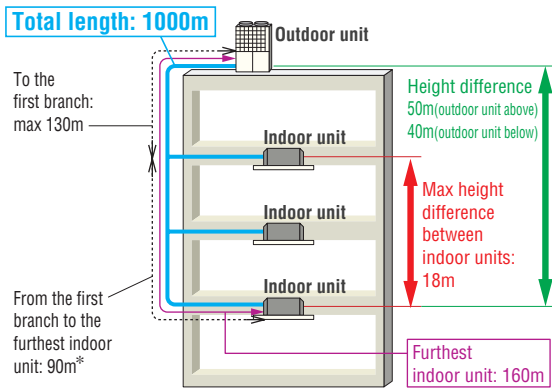

* The difference between the longest and the shortest indoor unit piping from the first branch must be within 40m.

Range of operation

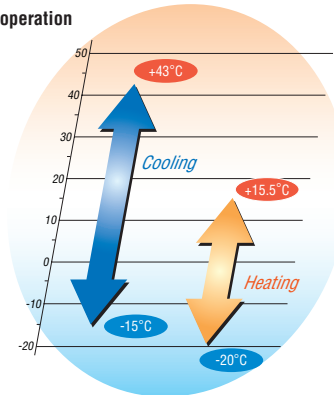

Specifications

Item	Model	FDC504KXE6	FDC560KXE6	FDC615KXE6	FDC680KXE6	
Nominal horse power		18HP	20HP	22HP	24HP	
Power source		3 Phase 380-415V, 50Hz				
Nominal capacity	Cooling	50.4	56.0	61.5	68.0	
	Heating	56.5	63.0	69.0	73.0	
Electrical characteristics	Starting current	8				
	Power consumption	Cooling	14.73	16.79	20.37	24.98
		Heating	15.12	16.79	18.48	19.08
	Running current	Cooling	24.1-22.0	27.4-25.1	33.1-30.3	40.3-36.9
Heating		25.2-23.1	28.0-25.7	30.7-28.1	31.6-29.0	
Exterior dimensions	HxWxD	2048x1350x720				
Net weight	kg	341		355		
Refrigerant charge	R410A	11.5		11.5		
Sound pressure level	Cooling/Heating	61.5/62.0	63.0/63.5	64.5/64.0	65.0/65.0	
Refrigerant piping size	Liquid line	ø12.7(1/2")				
	Gas line	ø28.58(1 1/8")				
Capacity connection	%	50~160				
Number of connectable indoor units		36	40	44	49	

1. The data are measured under the following conditions(ISO-T1). Cooling: Indoor temp. of 27°CDB, 19°CWB, and outdoor temp. of 35°CDB. Heating: Indoor temp. of 20°CDB, and outdoor temp. of 7°CDB, 6°CWB. Piping length is 7.5m.
 2. Sound pressure level indicates the value in an anechoic chamber. During operation these values are somewhat higher due to ambient conditions.

Dimensions

All measurements in mm.

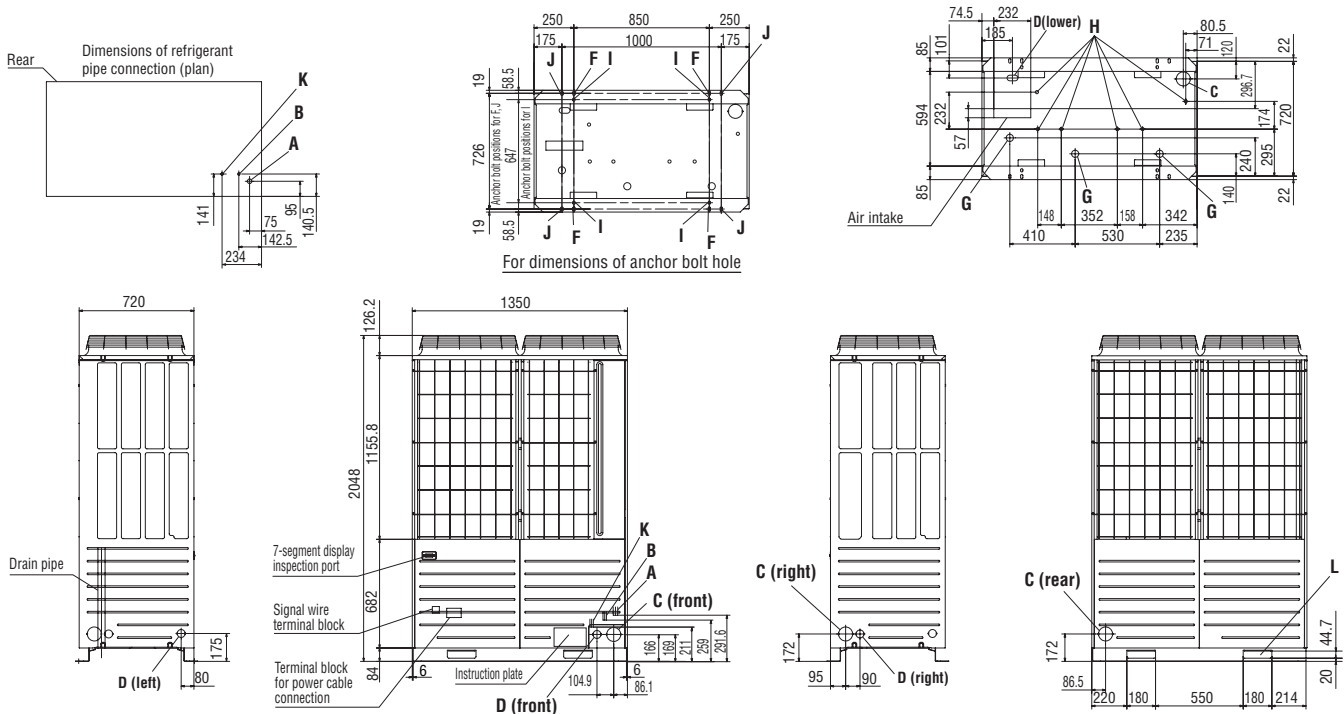

Mark	Item	
A	Service valve connection (gas side)	For refrigerant piping, please refer to the unit specifications.
B	Service valve connection (liquid line)	
C	Refrigerant pipe draw-out port	ø100
D	Power cable draw-in port	ø50
F	Anchor bolt hole	M10 x 4 places
G	Drain hose hole	ø45 x 3 places
H	Drain discharge port	ø20 x 6 places
K	Oil-equalising pipe joint	ø9.52 flare
L	Sling holes for haulage or hoisting	180 x 44.7

Installation example		
Dimensions	1	2
L1	500	Open
L2	10	200
L3	100	300
L4	10	Open
H1	1500	-
H2	No restrictions	No restrictions
H3	1000	No restrictions
H4	No restrictions	-

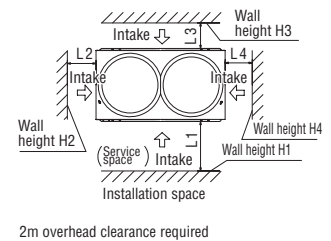

Notes:

- (1) The unit must be fixed with anchor bolts.
- (2) Leave a 2m or larger space above the unit.
- (3) The unit name plate is attached on the lower right corner of the front panel.
- (4) The ports for refrigerant pipe and power cable penetrations are covered with half-blanks. Please cut off a half-blank with nippers in using these ports.
- (5) Use a ø88 port for refrigerant pipe connection.
- (6) Anchor holes marked "L J" (four holes for M10) are for a renewal installation.
- (7) The oil-equalising pipe K should be used when outdoor units are used in combination.



KX6 Outdoor units

Heat pump combination systems

26, 28, 30, 32hp (73.5kW~90.0kW)



Model No.	Nominal Cooling Capacity
FDC735KXE6 (FDC335-K+FDC400)	73.5kW
FDC800KXE6 (FDC400x2)	80.0kW
FDC850KXE6 (FDC400+FDC450)	85.0kW
FDC900KXE6 (FDC450x2)	90.0kW

- The KX6 heat pump 2-pipe systems offer high performance VRF for applications that require either cooling only or heating only, ideal for open plan areas.
- Connect up to 65 indoor units/up to 160% capacity.
- High efficiency with COP (in cooling) up to 3.6.
- KX6 employs DC inverter compressors ONLY.
- Industry leading total piping length up to 1000m and a maximum pipe run of 160m.



Uniform footprint of all models (from 8hp~24hp) allows continuous side-by-side installation

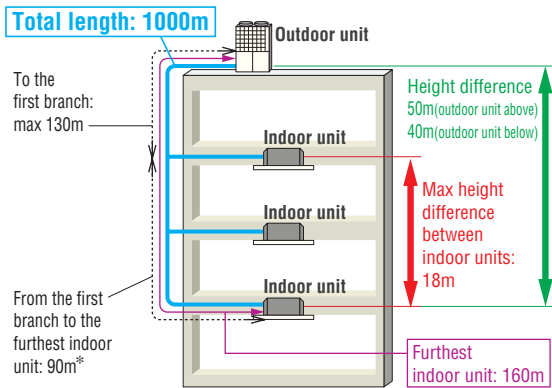

* The difference between the longest and the shortest indoor unit piping from the first branch must be within 40m.

Range of operation

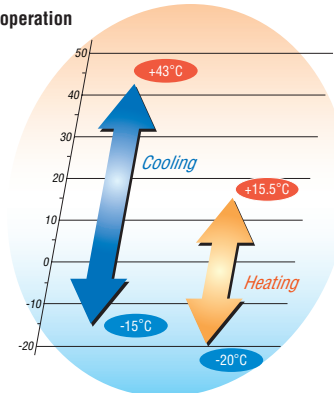

Specifications

Item	Model	FDC735KXE6	FDC800KXE6	FDC850KXE6	FDC900KXE6	
Combination (FDC)		335KXE6-K	400KXE6	400KXE6	450KXE6	
		400KXE6	400KXE6	450KXE6	450KXE6	
Nominal horse power		26HP	28HP	30HP	32HP	
Power source		3 Phase 380-415V, 50Hz				
Nominal capacity	Cooling	73.5	80.0	85.0	90.0	
	Heating	82.5	90.0	95.0	100.0	
Electrical characteristics	Starting current	A 16				
	Power consumption	Cooling	20.21	22.54	24.24	25.94
		Heating	20.66	23.46	24.83	26.20
	Running current	Cooling	32.9-30.2	36.8-33.8	39.5-36.2	42.2-38.6
Heating		34.4-31.4	39.2-35.8	41.3-37.8	43.4-39.8	
Exterior dimensions	HxWxD	mm 1690x2700x720				
Net weight		kg 317x2				
Refrigerant charge	R410A	kg 11.5x2				
Refrigerant piping size	Liquid line	mm(in) ø15.88(5/8")				
	Gas line	mm(in) ø31.8(1 1/4") [ø34.92(1 3/8")]				
Capacity connection	%	50~160				
Number of connectable indoor units		53	58	61	65	

1. The data are measured under the following conditions(ISO-T1). Cooling: Indoor temp. of 27°CDB, 19°CWB, and outdoor temp. of 35°CDB. Heating: Indoor temp. of 20°CDB, and outdoor temp. of 7°CDB, 6°CWB. Piping length is 7.5m.
 2. Sound pressure level indicates the value in an anechoic chamber. During operation these values are somewhat higher due to ambient conditions.
 3. [] : Pipe sizes applicable to European installations are shown in parentheses.

Dimensions

All measurements in mm.

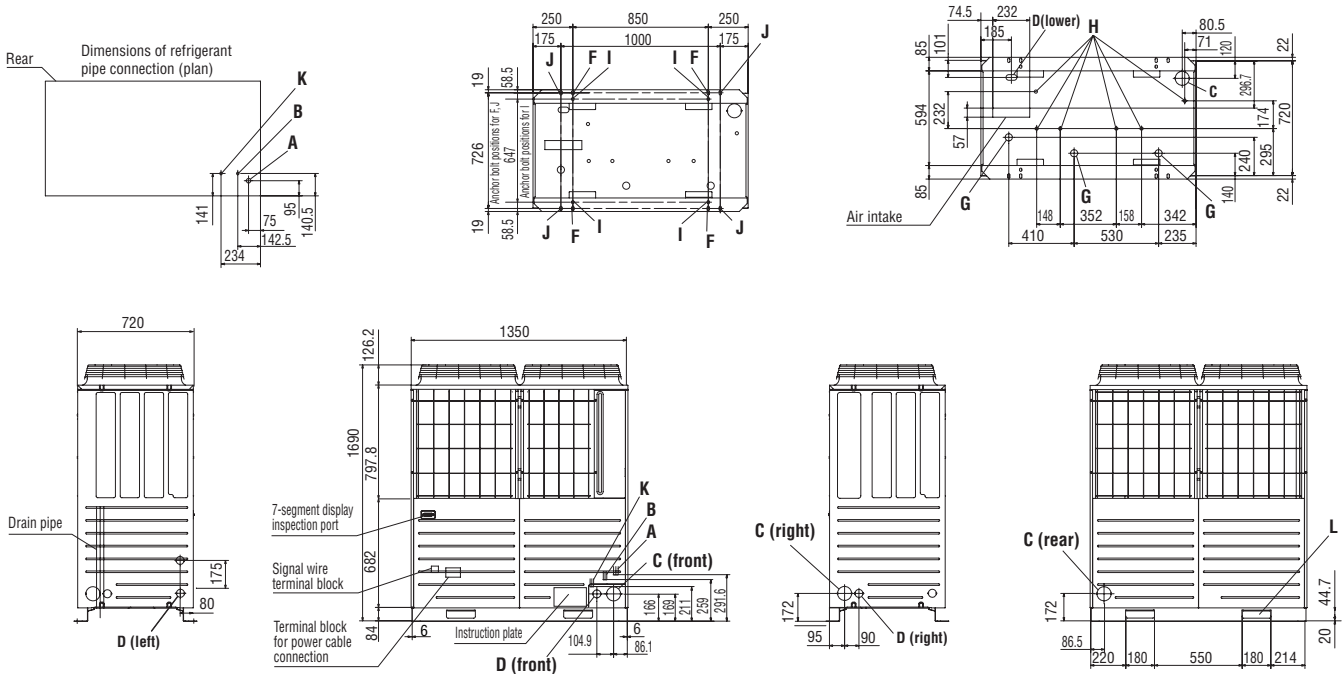

Mark	Item	
A	Service valve connection (gas side)	For refrigerant piping, please refer to the unit specifications.
B	Service valve connection (liquid line)	
C	Refrigerant pipe draw-out port	ø88
D	Power cable draw-in port	ø50
F	Anchor bolt hole	M10 x 4 places
G	Drain hose hole	ø45 x 3 places
H	Drain discharge port	ø20 x 6 places
K	Oil-equalising pipe joint	ø3/8" flare
L	Sling holes for haulage or hoisting	180 x 44.7

Notes:

- (1) The unit must be fixed with anchor bolts.
- (2) Leave a 2m or larger space above the unit.
- (3) The unit name plate is attached on the lower right corner of the front panel.
- (4) The ports for refrigerant pipe and power cable penetrations are covered with half-blanks. Please cut off a half-blank with nippers in using these ports.
- (5) Use a ø88 port for refrigerant pipe connection.
- (6) Anchor holes marked "L J" (four holes for M10) are for a renewal installation.
- (7) The oil-equalising pipe K should be used when outdoor units are used in combination.



KX6 Outdoor units

Heat pump combination systems

34, 36, 38, 40, 42, 44, 46, 48hp (96.0kW~136.0kW)

Model No.	Nominal Cooling Capacity
FDC960KXE6 (FDC450+FDC504)	96.0kW
FDC1010KXE6 (FDC504x2)	101.0kW
FDC1065KXE6 (FDC504+FDC560)	106.5kW
FDC1130KXE6 (FDC560x2)	113.0kW
FDC1180KXE6 (FDC560-K+FDC615)	118.0kW
FDC1235KXE6 (FDC615x2)	123.5kW
FDC1300KXE6 (FDC615+FDC680)	130.0kW
FDC1360KXE6 (FDC680x2)	136.0kW



- The KX6 heat pump 2-pipe systems offer high performance VRF for applications that require either cooling only or heating only, ideal for open plan areas.
- Connect up to 80 indoor units/up to 130% (960KXE6:160%) capacity.
- High efficiency with COP (in cooling) up to 3.5.
- KX6 employs DC inverter compressors ONLY.
- Industry leading total piping length up to 1000m and a maximum pipe run of 160m.

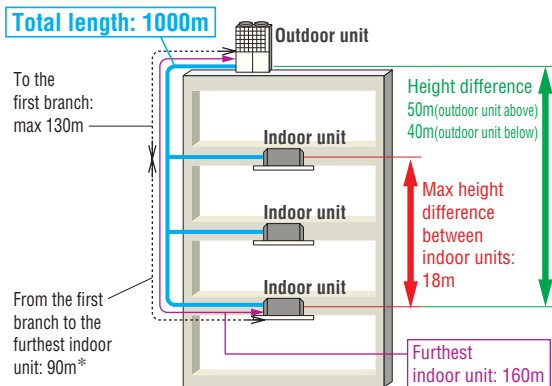

* The difference between the longest and the shortest indoor unit piping from the first branch must be within 40m.

Range of operation

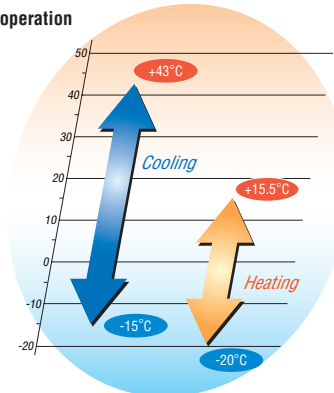

Specifications

Item	Model	FDC960KXE6	FDC1010KXE6	FDC1065KXE6	FDC1130KXE6	FDC1180KXE6	FDC1235KXE6	FDC1300KXE6	FDC1360KXE6		
Combination (FDC)		450KXE6	504KXE6	504KXE6	560KXE6	560KXE6-K	615KXE6	615KXE6	680KXE6		
		504KXE6	504KXE6	560KXE6	560KXE6	615KXE6	615KXE6	680KXE6	680KXE6		
Nominal horse power		34HP	36HP	38HP	40HP	42HP	44HP	46HP	48HP		
Power source		3 Phase 380-415V, 50Hz									
Nominal capacity	Cooling	kW	96.0	101.0	106.5	113.0	118.0	123.5	130.0	136.0	
	Heating	kW	108.0	113.0	119.5	127.0	132.0	138.0	142.0	146.0	
Electrical characteristics	Starting current	A	16								
	Power consumption	Cooling	kW	27.70	29.46	31.52	33.58	37.16	40.74	45.35	49.96
		Heating	kW	28.22	30.24	31.91	33.58	35.27	36.96	37.56	38.16
	Running current	Cooling	A	45.2-41.3	48.2-44.0	51.5-47.1	54.8-50.2	60.5-55.4	66.2-60.6	73.4-67.2	80.6-73.8
Heating		A	46.9-43.0	50.4-46.2	53.2-48.8	56.0-51.4	58.7-53.8	61.4-56.2	62.3-57.1	63.2-58.0	
Exterior dimensions	HxWxD	mm	2048x2700x720								
Net weight		kg	341+317	341x2				355x2			
Refrigerant charge	R410A	kg	11.5x2								
Refrigerant piping size	Liquid line	mm(in)	ø15.88(5/8")				ø19.05(3/4")				
	Gas line	mm(in)	ø34.92(1 3/8")								
Capacity connection	%		50~160	50~130							
Number of connectable indoor units			69	59	62	66	69	72	76	80	

1. The data are measured under the following conditions(ISO-T1). Cooling: Indoor temp. of 27°CDB, 19°CWB, and outdoor temp. of 35°CDB. Heating: Indoor temp. of 20°CDB, and outdoor temp. of 7°CDB, 6°CWB. Piping length is 7.5m.
 2. Sound pressure level indicates the value in an anechoic chamber. During operation these values are somewhat higher due to ambient conditions.

Dimensions

All measurements in mm.

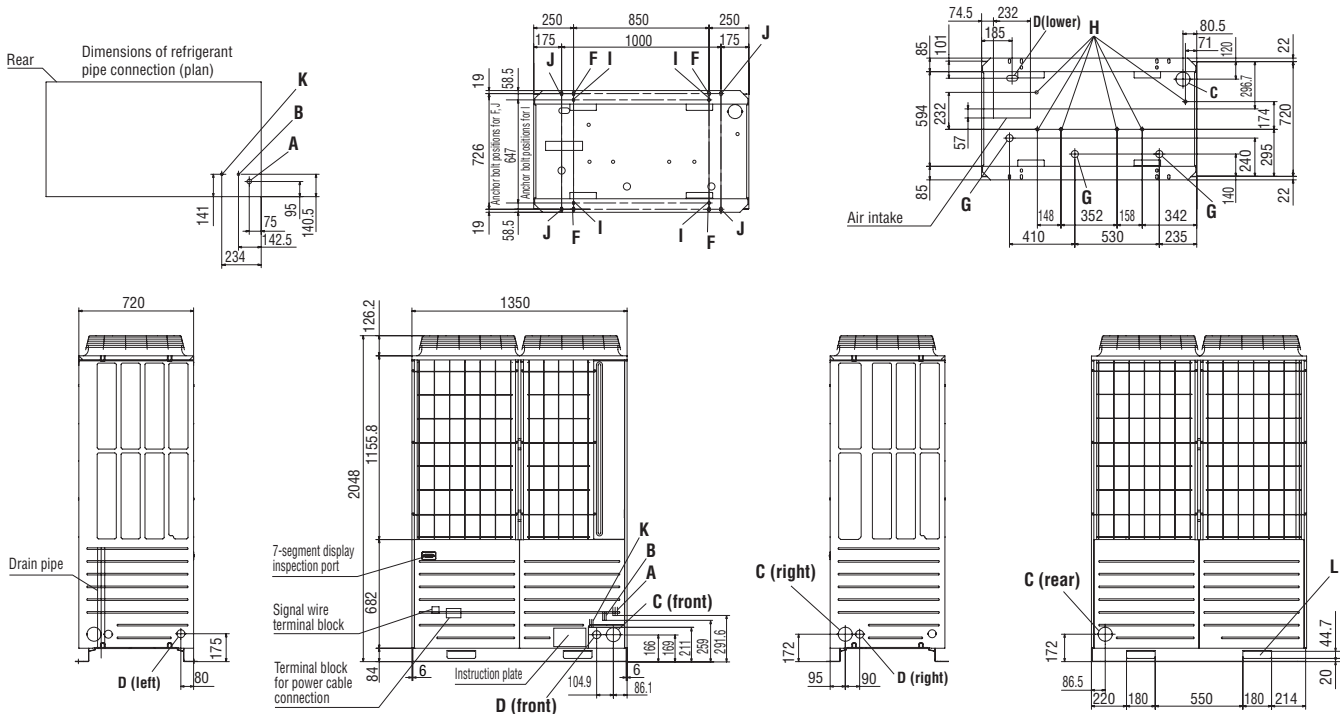

Mark	Item	
A	Service valve connection (gas side)	For refrigerant piping, please refer to the unit specifications.
B	Service valve connection (liquid line)	
C	Refrigerant pipe draw-out port	ø100
D	Power cable draw-in port	ø50
F	Anchor bolt hole	M10 x 4 places
G	Drain hose hole	ø45 x 3 places
H	Drain discharge port	ø20 x 6 places
K	Oil-equalising pipe joint	ø9.52 flare
L	Sling holes for haulage or hoisting	180 x 44.7

Notes:

- (1) The unit must be fixed with anchor bolts.
- (2) Leave a 2m or larger space above the unit.
- (3) The unit name plate is attached on the lower right corner of the front panel.
- (4) The ports for refrigerant pipe and power cable penetrations are covered with half-blanks. Please cut off a half-blank with nippers in using these ports.
- (5) Use a ø88 port for refrigerant pipe connection.
- (6) Anchor holes marked "L J" (four holes for M10) are for a renewal installation.
- (7) The oil-equalising pipe K should be used when outdoor units are used in combination.



KX6 refrigerant piping

Installation of Interconnecting Pipework

Mitsubishi KX6 equipment is manufactured to the highest standards of quality and reliability. It is imperative the method of installation and the materials used are also to high standards, to ensure trouble free operation and long term reliability.

The interconnecting pipework must be installed by a competent and trained engineer. Refrigeration quality copper tube must be used, soft copper coils or half-hard straight lengths. The refrigeration quality tube must be soft drawn seamless high grade copper pipe. The copper tube must be selected taking into account the higher operating pressures of R410A refrigerant, and that high pressures will occur throughout the system because of the reverse cycle operation. All pipework material used should be EN12735 European standard.

The supplied branch pipe kits, must be used to make connections to indoor units, and the supplied manifold kits must be used to make connections between outdoor units (where applicable); it is not permitted to use standard fittings such as elbows, tees etc. The branch pipes shall be installed in accordance with the manufacturer's instructions, allowing unrestricted flow of refrigerant, and in accordance with European standard E378:2000. All brazed joints shall be made with dry nitrogen purge to ensure the prevention of oxidation to the internal surface of the copper pipes.

The ingress of moisture, dirt and any other contaminants to the interior of the copper pipes, and air conditioning units, must be prevented during the installation procedure. After the installation of pipework, prior to the

connection of the outdoor units, and sealing of insulation joints, the pipework must be pressure tested for leakage, using dry nitrogen.

Additional Refrigerant

Additional R410A refrigerant only shall be used, and must be charged by weight only, using electronic scales. The amount of additional refrigerant must be accurately calculated from the manufacturer's data, based on the length and diameter of each section of the liquid refrigerant pipework of the system.

Single outdoor unit piping examples:

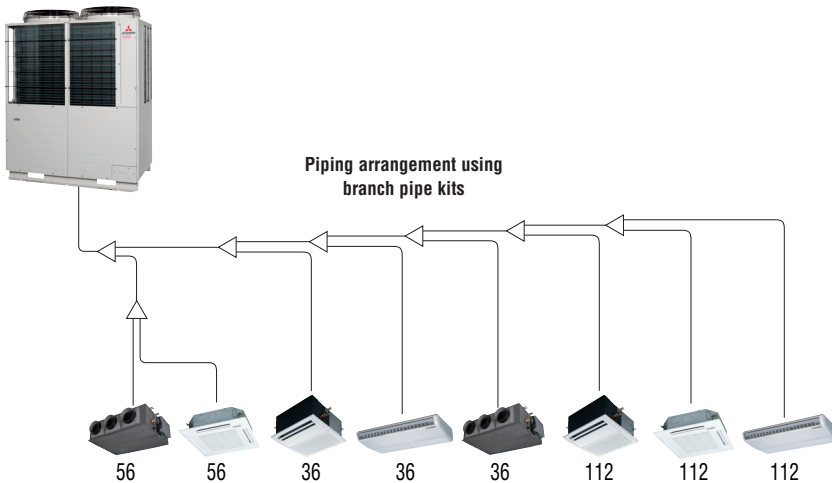
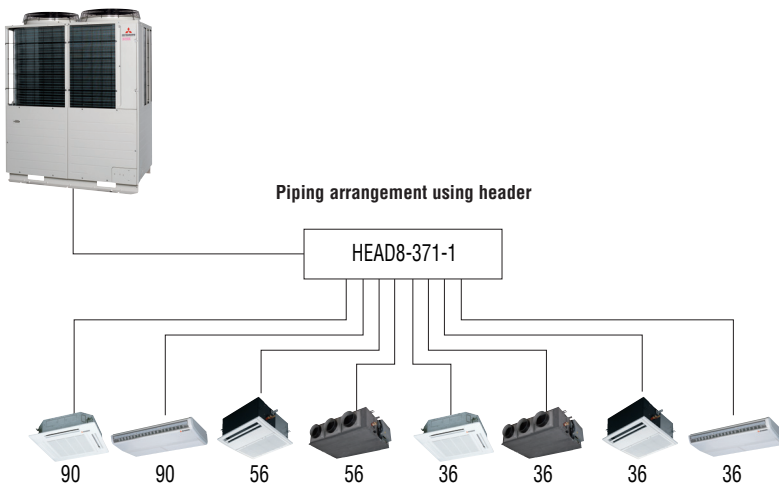

Liquid pipe
Gas pipe

KX6 refrigerant piping

Pipe sizes applicable to European installations.

Outdoor unit (HP)		8	10	12	14	16	18	20	22	24	26	28	30	32	34	36	38	40	42	44	46	48
Liquid pipe	Furthest indoor unit =<90m	ø9.52		ø12.7						ø15.88						ø19.05						
Gas pipe		ø19.05	ø22.22	ø28.58						ø34.92												
Liquid pipe	Furthest indoor unit =>90m	ø12.7		ø15.88						ø19.05						ø22.22						
Gas pipe		ø22.22	ø28.58								ø34.92											

mm	inch	mm	inch
ø9.52	3/8"	ø28.58	1 1/8"
ø12.7	1/2"	ø31.8	1 1/4"
ø15.88	5/8"	ø34.92	1 3/8"
ø19.05	3/4"	ø38.1	1 1/2"
ø22.22	7/8"	ø44.5	1 3/4"
ø25.4	1"	ø50.8	2"

Branch pipes

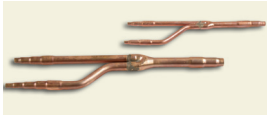

DIS-22-1/DIS-180-1

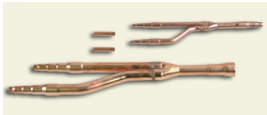

DIS-371-1/DIS-540-2

Header pipe



HEAD6-180-1

Combination outdoor unit manifold



DOS-2A-1

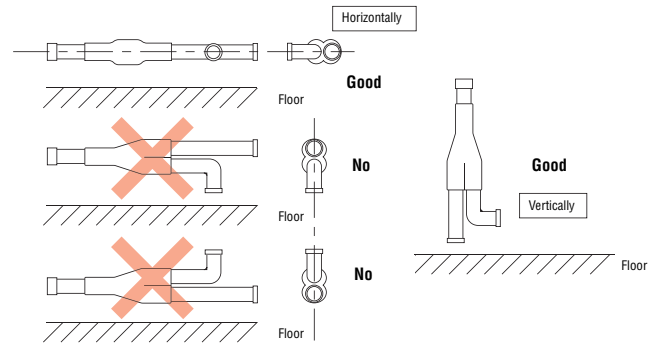

Combination outdoor unit piping examples:

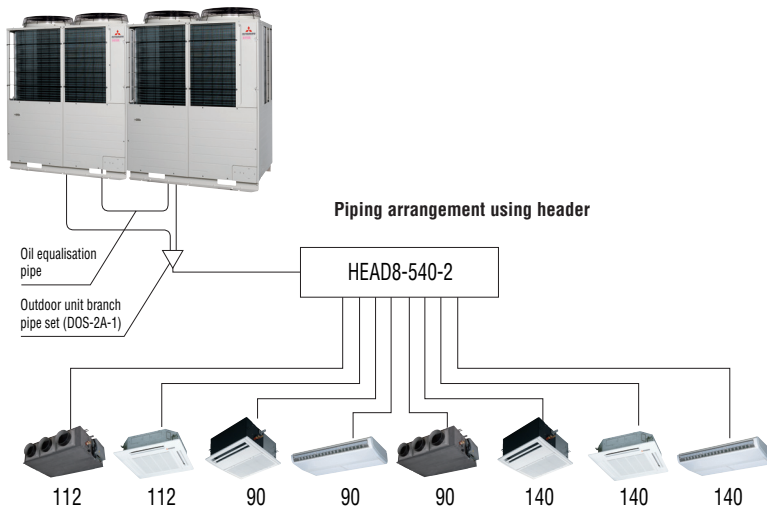
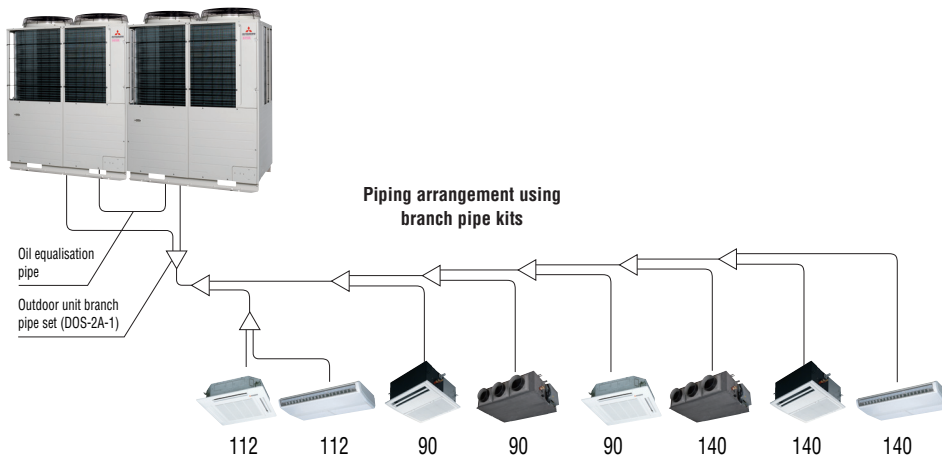

Outdoor unit's branching piping

Outdoor unit	Branch piping set
2 units (for 735~1360)	DOS-2A-1

Indoor unit's first branching piping

Total capacity of indoor units	Branch piping set	Header set	
		Model	Branches
~179	DIS-22-1	HEAD4-22-1	Max 4 branches
180~370	DIS-180-1	HEAD6-180-1	Max 6 branches
371~539	DIS-371-1	HEAD8-371-1	Max 8 branches
540~	DIS-540-2	HEAD8-540-2	Max 8 branches



KX6 electrical wiring – power supply

KX6 new design includes greatly simplified wiring requirements utilising a ‘polarity-free’ two wire control loop connecting the indoor units.

Power wiring

Cables can be laid through the front, right, left or bottom of the outdoor unit casing.

Separate power supplies should be used for the outdoor unit (3/phase) and the indoor units (1/phase).

Only control wiring is connected from outdoor to indoor unit.

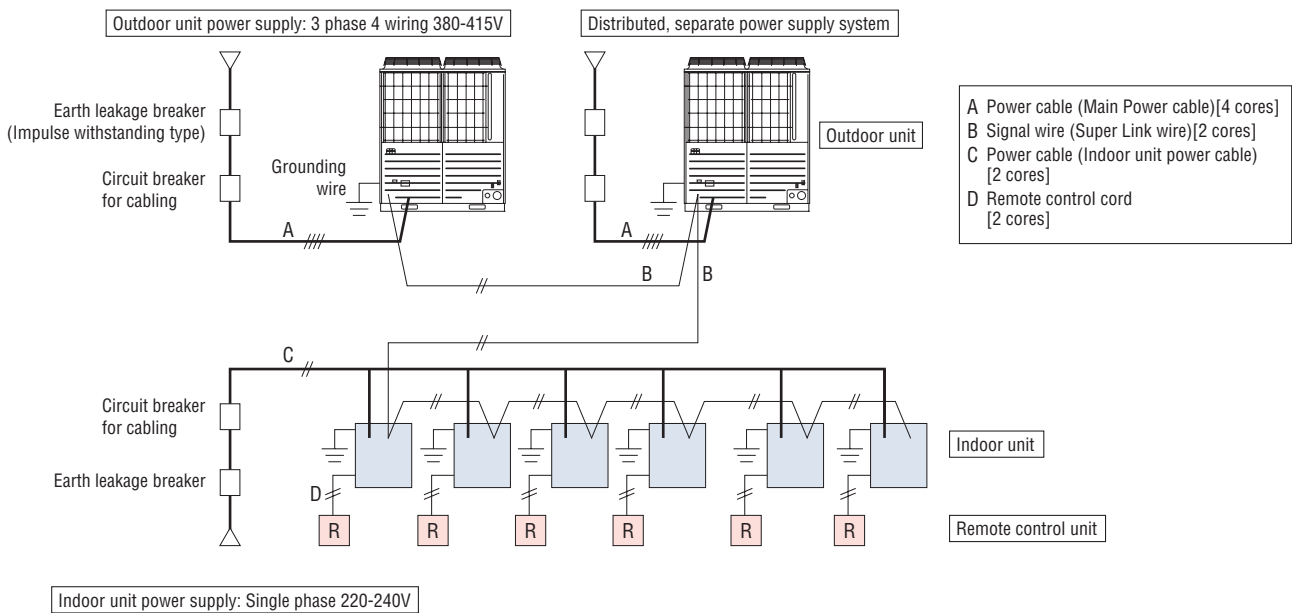

CAUTION

If the earth leakage breaker is exclusively for ground fault protection, then you will need to install a circuit breaker for wiring work.

KX6 outdoor unit mechanical compartment

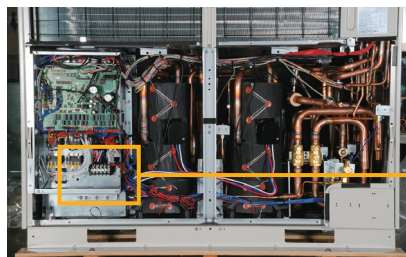

Electrical component box

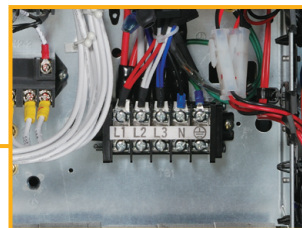

Outdoor unit power supply terminal block

KX6 electrical wiring – control wiring

1. The control wiring is 5 Volt DC, non-polarised, two wire connection notated as 'A1' and 'B1'. This 'AB' wiring connects outdoor unit to indoor unit and indoor unit to indoor unit.

2. This wiring must be a 2-core shielded cable size 0.75mm² or 1.25mm².

	0.75mm ²	1.25mm ²
~1000m	YES	YES
1000~1500m	YES	NO

3. We recommend the both ends of the shield of the cable are connected to ground (earth) at all the indoor units and outdoor units.

4. When plural outdoor units are used,
 • Connect the signal cable between indoor and outdoor units and the signal cable between outdoor units belonging to the same refrigerant line to A1 and B1.
 • Connect the signal line between outdoor units on different refrigerant lines to A2 and B2.

5. For current specification of 2-core (AB) wiring, please consult your MHI dealer.

(1) When one outdoor unit is used

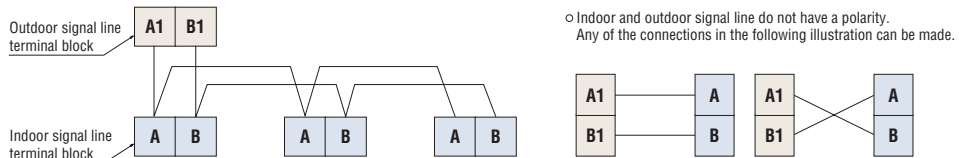

(2) When plural outdoor units are used

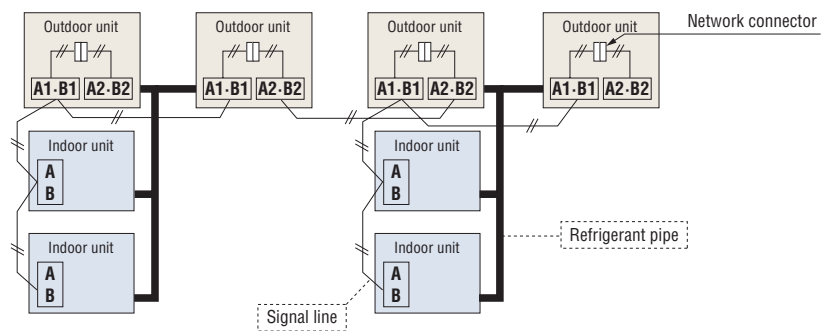

- (a) The maximum number of indoor units that can be connected in a system is 128 and it is possible to configure outdoor units and/or indoor units as an outdoor or indoor unit group connected with each other with two wires.
- (b) The signal wires can also be connected using the method shown below.

(3) The signal lines can also be connected using the method shown below.

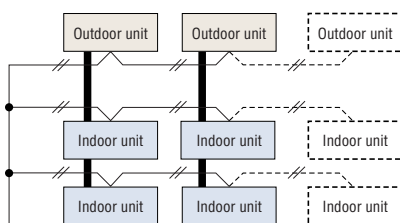

Important

Loop wiring prohibited

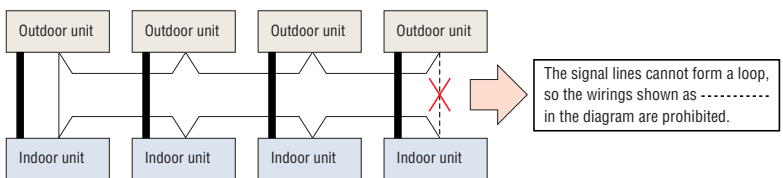

Remote control wiring specifications

For interconnecting wiring between the remote control and indoor units (XY wiring) use 2-core cable size 0.3mm². The maximum length of 2-core cable is 600 metres. Where the 2-core wiring exceeds 100m, use the wire size detailed on the table opposite.

Length (m)	Wire size
100 to 200	0.5mm ² x 2 core
To 300	0.75mm ² x 2 core
To 400	1.25mm ² x 2 core
To 600	2.0mm ² x 2 core

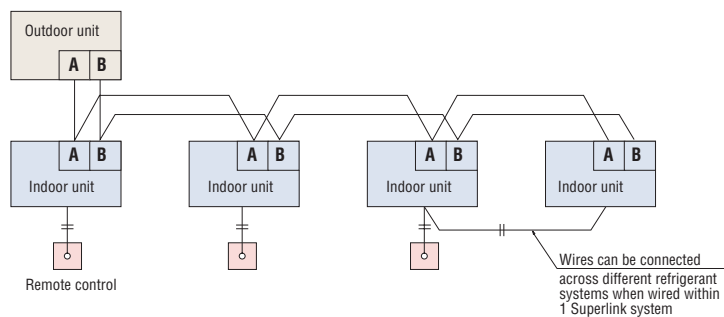



KXR6 heat recovery systems - for simultaneous heating and cooling

KXR6 heat recovery systems operate with 3 inter-connecting pipes, thus commonly referred to as a '3-pipe system'.

KXR6 systems provide both heating and cooling operations to individual indoor units according to the room condition/requirement. KXR6 incorporates highly sophisticated control to condition multiple indoor areas, whatever their requirement for cooling or heating, for applications

where the building orientation (N, S, E, W) can mean that heat gain/loss varies on each side of the building.

The range starts from the 8hp model (22.4kW) cooling capacity, up to the largest capacity single outdoor unit in the industry (24hp) with 68.0kW cooling capacity. Outdoor units can also be "twinned" providing up to 48HP/136.0kW on a single system.



KXR6

8HP	10HP	12HP	12HP	14HP	16HP
FDC224KXRE6	FDC280KXRE6	FDC335KXRE6	FDC335KXRE6-K	FDC400KXRE6	FDC450KXRE6
18HP	20HP	20HP	22HP	24HP	
FDC504KXRE6	FDC560KXRE6	FDC560KXRE6-K	FDC615KXRE6	FDC680KXRE6	

KXR6

26HP	28HP	30HP	32HP	34HP	36HP
FDC735KXRE6	FDC800KXRE6	FDC850KXRE6	FDC900KXRE6	FDC960KXRE6	FDC1010KXRE6
12+14	14+14	14+16	16+16	16+18	18+18
FDC335KXRE6-K FDC400KXRE6	FDC400KXRE6 FDC400KXRE6	FDC400KXRE6 FDC450KXRE6	FDC450KXRE6 FDC450KXRE6	FDC450KXRE6 FDC504KXRE6	FDC504KXRE6 FDC504KXRE6
38HP	40HP	42HP	44HP	46HP	48HP
FDC1065KXRE6	FDC1130KXRE6	FDC1180KXRE6	FDC1235KXRE6	FDC1300KXRE6	FDC1360KXRE6
18+20	20+20	20+22	22+22	22+24	24+24
FDC504KXRE6 FDC560KXRE6	FDC560KXRE6 FDC560KXRE6	FDC560KXRE6-K FDC615KXRE6	FDC615KXRE6 FDC615KXRE6	FDC615KXRE6 FDC680KXRE6	FDC680KXRE6 FDC680KXRE6

1. 12HP, 20HP, 22HP & 24HP are applied 3D compressor.
2. FDC335KXRE6-K & FDC560KXRE6-K are only used for combining with other models.

Capacity connection

HP	KXR4
8~12	130%
14,16	130%
18~34	130%
36~48	130%



HP	KXR6
8~16	200%
18~34	160%
36~48	130%

- In case that capacity connection is more than 130%, additional charge of refrigerant is required on site.
- In case of 8-34HP of KXR6 system, if one or more indoor units of FDK, FDFL, FDFU and/or FDFW series are connected to the system, the total connecting capacity of indoor units should not exceed 130%.

Up to 80 indoor units can be connected to the largest capacity outdoor unit, with a range of 16 types of exposed or concealed indoor unit, in several capacities, a choice of 80 indoor units is available.



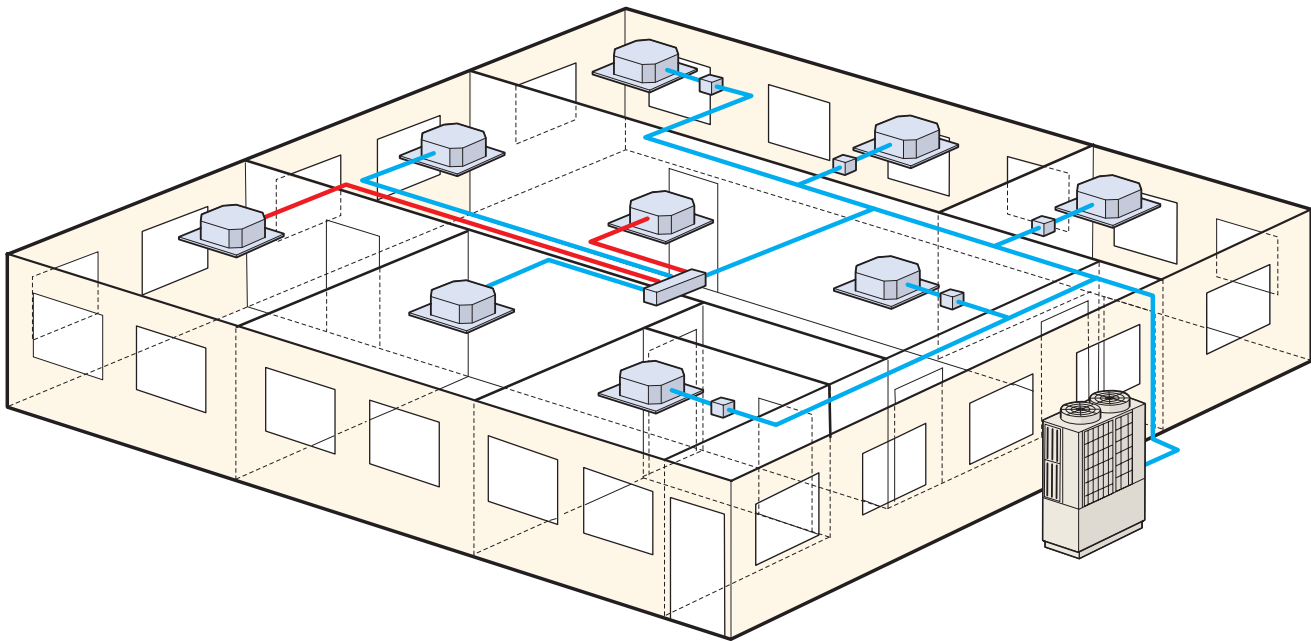

KXR6 heat recovery systems - for simultaneous heating and cooling

The KXR6 system interconnecting pipework has a unique arrangement, with two of the interconnecting pipes routed through a PFD Distribution Controller, and the third pipe connected directly to each indoor unit from the main pipe run. This reduces installation time, and the number of brazed connections on site. The PFD Distribution Controllers are available for single connection, or as a combined PFD 4-way connection, with each connected unit having independent cooling or heating operation.

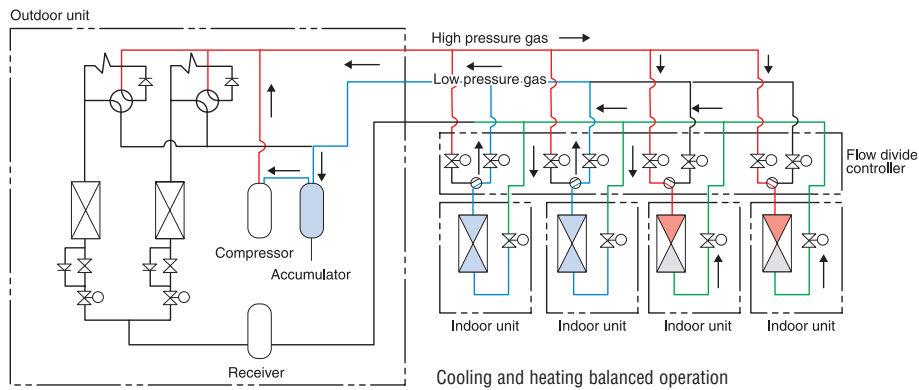

During defrosting or during automatic protection of a compressor, which is activated every several hours in heating operation, heating operation temporarily stops and restarts after some period. KXR6 series has the same automatic protection of compressor in cooling operation also. During this protection period air flow only comes on and cooling operation restarts after some period.

The industry's highest COP levels

We have cleared the class A standard, the highest energy saving level, with our high COP (Coefficient Of Performance).

EER in Cooling

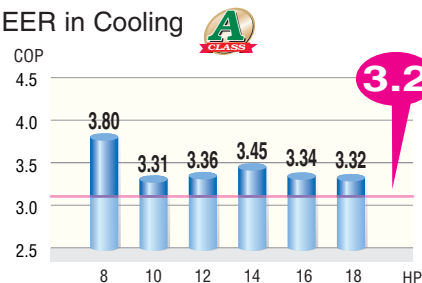

COP in Heating

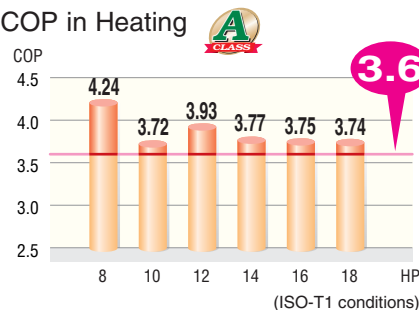

*COP = Capacity[kW] / Power Consumption[kW]

*COP across the KXR6 range ensures reduced running costs and reduced environmental impact.



KXR6 Outdoor units

Heat recovery 3-pipe systems 8, 10, 12, 14, 16hp (22.4kW – 45.0kW) for simultaneous heating and cooling

Model No.	Nominal Cooling Capacity
FDC224KXRE6	22.4kW
FDC280KXRE6	28.0kW
FDC335KXRE6	33.5kW
FDC400KXRE6	40.0kW
FDC450KXRE6	45.0kW

- The KXR6 heat recovery systems offer high performance VRF for almost every type of building, with the capacity for simultaneous heating and cooling operations of individual indoor units. Energy efficiency is maximised by employing DC inverter compressors ONLY, and distributing surplus heat from cooling operations to areas where it is required (and vice versa) resulting in COP (in cooling) from 3.7 to 4.2.
- Connect from 50% up to 200% capacity indoor units.
- Industry leading total piping length up to 1000m and a maximum pipe run of 160m.



Uniform footprint of all models (from 8hp-24 hp) allows continuous side-by-side installation

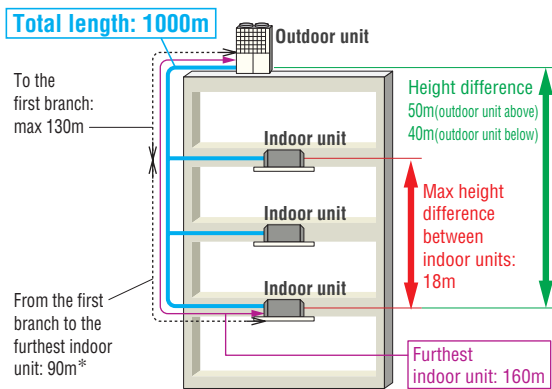

* The difference between the longest and the shortest indoor unit piping from the first branch must be within 40m.

Range of operation

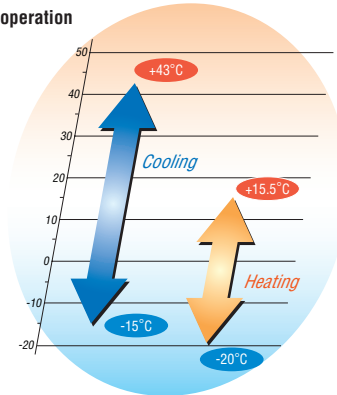

Specifications

Item		FDC224KXRE6	FDC280KXRE6	FDC335KXRE6	FDC400KXRE6	FDC450KXRE6	
Nominal horse power		8HP	10HP	12HP	14HP	16HP	
Power source		3 Phase 380-415V, 50Hz					
Nominal capacity	Cooling	22.4	28.0	33.5	40.0	45.0	
	Heating	25.0	31.5	37.5	45.0	50.0	
Electrical characteristics	Starting current	A				8	
	Power consumption	Cooling	5.90	8.46	9.98	11.61	13.49
		Heating	5.90	8.46	9.55	11.93	13.32
	Operating current	Cooling	9.1-8.3	13.5-12.3	15.9-14.8	19.0-17.4	21.6-19.8
Heating		9.2-8.4	13.4-12.3	15.5-14.2	19.9-18.2	22.0-20.1	
Exterior dimensions	HxWxD	mm 1690x1350x720					
Net weight	kg	252		256	337		
Refrigerant charge	R410A	8.7	9.9	11.4	11.5		
Sound pressure level	Cooling/Heating	dB(A) 57/57		58/59	62/63	60/60 62.5/62.5	
Refrigerant piping size	Liquid line	ø9.52(3/8")			ø12.7(1/2")		
	Suction Gas line	ø19.05(3/4")	ø25.4(1") [ø22.22(7/8")]		ø25.4(1") [ø28.58(1 1/8")]		
	Discharge Gas line	ø15.88(5/8")	ø19.05(3/4")		ø22.22(7/8")		
Capacity connection	%	50-200					
Number of connectable indoor units		20	25	30	36	40	

1. The data are measured under the following conditions(ISO-T1). Cooling: Indoor temp. of 27°CDB, 19°CWB, and outdoor temp. of 35°CDB. Heating: Indoor temp. of 20°CDB, and outdoor temp. of 7°CDB, 6°CWB. Piping length is 7.5m.
 2. Sound pressure level indicates the value in an anechoic chamber. During operation these values are somewhat higher due to ambient conditions.
 3. [] : Pipe sizes applicable to European installations are shown in parentheses.

Dimensions

All measurements in mm.

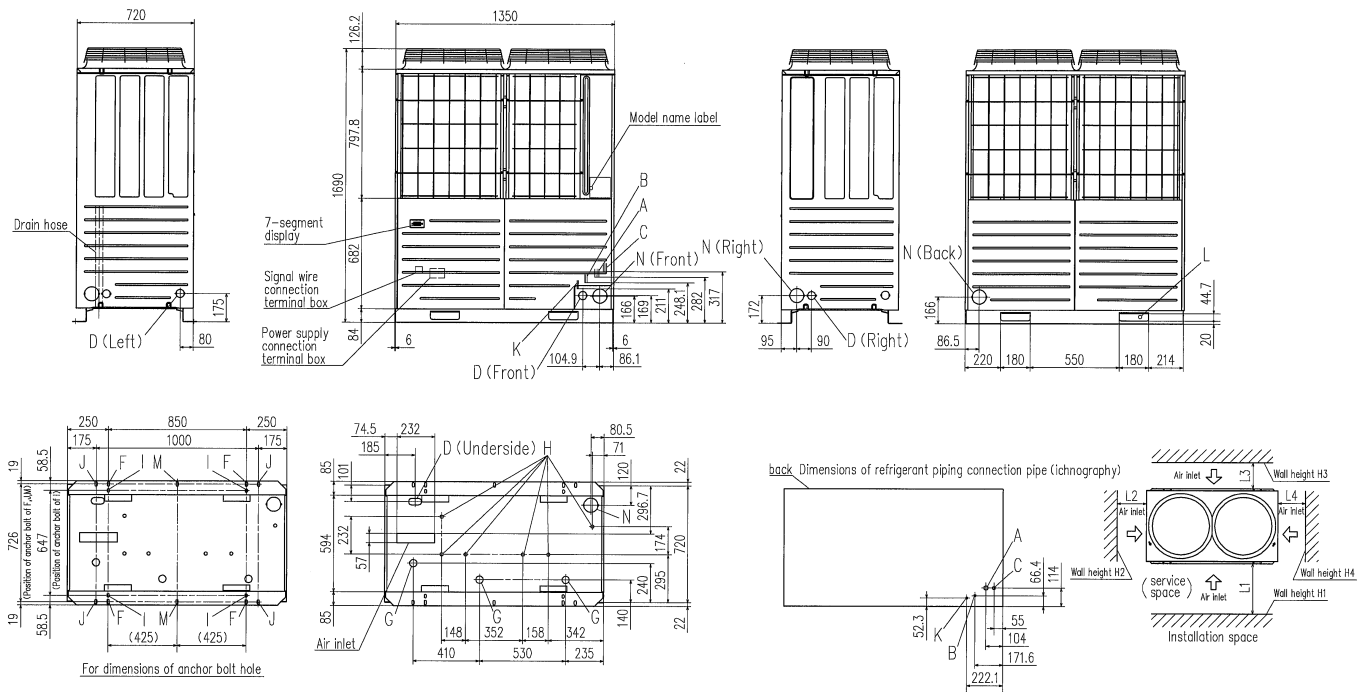

Mark	Content	224	280	335	335-K	400	450
A	Refrigerant suction gas piping connection entrance	ø19.05(Brazing)	ø22.22(Brazing)	ø25.4(Brazing)		ø28.58(Brazing)	
B	Refrigerant liquid piping connection entrance	ø9.52(Flare)		ø12.7(Flare)			
C	Refrigerant discharge gas piping connection entrance	ø15.88(Brazing)	ø19.05(Brazing)		ø22.22(Brazing)		
D	Power supply entry hole	ø50(right · left · front), long hole 40x80(under side)					
F	Anchor bolt hole	M10 x 4 places					
G	Drain waste water hose hole	ø45 x 3 places					
H	Drain hole	ø20 x 6 places					
K	Refrigerant oil equalization piping connection entrance	ø9.52(Flare)					
L	Carrying in or hole for hanging	180x44.7					
N	Refrigerant piping exit hole	ø88(or ø100)					

*14,16HP models only

Notes:

- Make sure to secure the unit with anchor bolts.
- Make sure to allow the space of 2m or more above the unit.
- Connect the refrigerant piping (suction gas side, discharge gas side, liquid side) at local site.
- The refrigerant piping connection entrance and the power supply intake are of the half blank shape. Cut it with the nipper etc., when you use.
- Use ø88 (or ø100) for the refrigerant piping connection entrance.
- Please use the anchor hole (M10x10) marked I and J and M for a renewal purpose.
- Please connect the oil equalization pipe marked K with only the outdoor combination unit. (for 14,16HP only)
- Please use combination trestle (option) when you use the trestle by outdoor combination unit. (for 14,16HP only)

Installation example		
Dimensions	1	2
L1	500	Open
L2	10	10
L3	100	100
L4	10	Open
H1	1500	-
H2	No limited	No limited
H3	1000	No limited
H4	No limited	-



KXR6 Outdoor units

Heat recovery 3-pipe systems 18, 20, 22, 24hp (50.4kW – 68.0kW) for simultaneous heating and cooling

Model No.	Nominal Cooling Capacity
FDC504KXRE6	50.4kW
FDC560KXRE6	56.0kW
FDC615KXRE6	61.5kW
FDC680KXRE6	68.0kW

- The KXR6 heat recovery systems offer high performance VRF for almost every type of building, with the capacity for simultaneous heating and cooling operations of individual indoor units. Energy efficiency is maximised by employing DC inverter compressors ONLY, and distributing surplus heat from cooling operations to areas where it is required (and vice versa) resulting in COP (in cooling) from 2.6 to 3.3.
- Connect from 50% up to 160% capacity indoor units.
- Industry leading total piping length up to 1000m and a maximum pipe run of 160m.



Uniform footprint of all models (from 8hp-24hp) allows continuous side-by-side installation

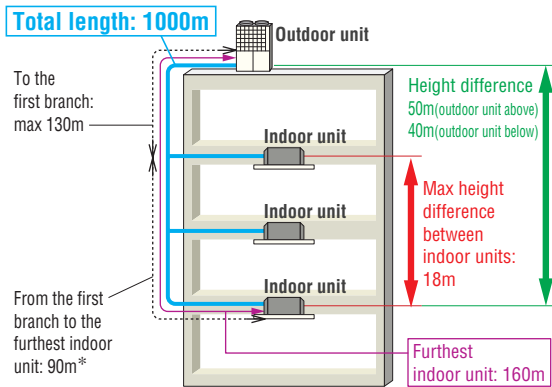

* The difference between the longest and the shortest indoor unit piping from the first branch must be within 40m.

Range of operation

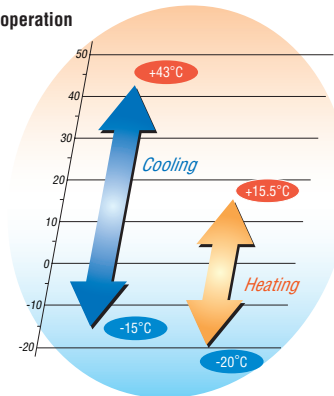

Specifications

Item		FDC504KXRE6	FDC560KXRE6	FDC615KXRE6	FDC680KXRE6	
Nominal horse power		18HP	20HP	22HP	24HP	
Power source		3 Phase 380-415V, 50Hz				
Nominal capacity	Cooling	50.4	56.0	61.5	68.0	
	Heating	56.5	63.0	69.0	73.0	
Electrical characteristics	Starting current	A 8				
	Power consumption	Cooling	15.18	17.95	21.47	25.99
		Heating	15.12	16.79	19.11	19.69
	Operating current	Cooling	23.8-21.8	28.4-26.0	34.7-31.8	44.9-41.1
Heating		25.2-23.1	28.0-25.7	31.6-28.9	34.0-31.1	
Exterior dimensions	HxWxD	mm 2048x1350x720				
Net weight	kg	361		375		
Refrigerant charge	R410A	kg 11.5				
Sound pressure level	Cooling/Heating	62/62	63.5/63.5	64/64.5	65.5/65.5	
	Refrigerant piping size	Liquid line	ø12.7(1/2")			
Suction Gas line		ø28.58(1 1/8")				
Discharge Gas line		ø22.22(7/8")		ø25.4(1") [ø22.22(7/8")]		
Capacity connection	%	50~160				
Number of connectable indoor units		36	40	44	49	

1. The data are measured under the following conditions (ISO-T1). Cooling: Indoor temp. of 27°CDB, 19°CWB, and outdoor temp. of 35°CDB. Heating: Indoor temp. of 20°CDB, and outdoor temp. of 7°CDB, 6°CWB. Piping length is 7.5m.
 2. Sound pressure level indicates the value in an anechoic chamber. During operation these values are somewhat higher due to ambient conditions.
 3. [] : Pipe sizes applicable to European installations are shown in parentheses.

Dimensions

All measurements in mm.

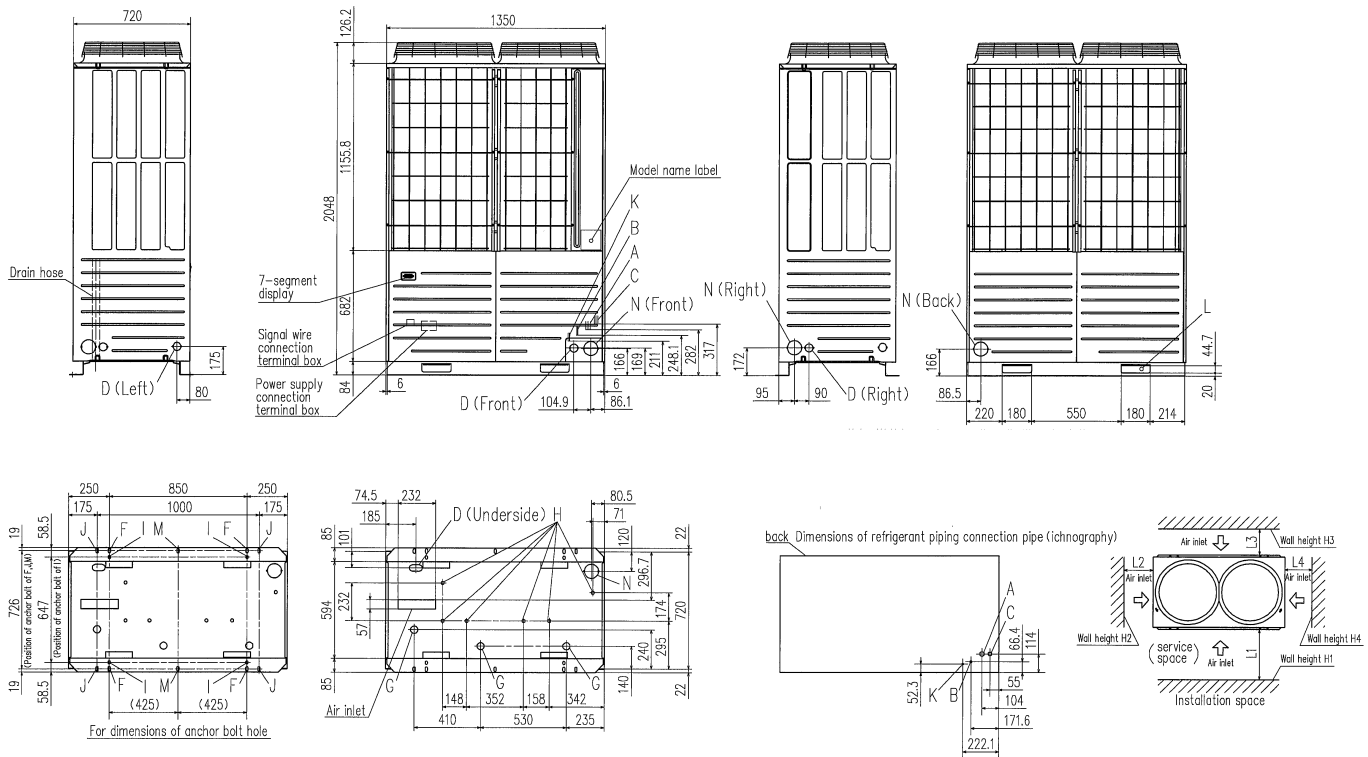

Mark	Content	504	560	560-K	615	680
A	Refrigerant suction gas piping connection entrance			ø28.58(Brazing)		
B	Refrigerant liquid piping connection entrance			ø12.7(Flare)		
C	Refrigerant discharge gas piping connection entrance	ø22.22(Brazing)		ø25.4(Brazing)		
D	Power supply entry hole	ø50(right · left · front),long hole 40x80(under side)				
F	Anchor bolt hole	M10 x 4 places				
G	Drain waste water hose hole	ø45 x 3 places				
H	Drain hole	ø20 x 6 places				
K	Refrigerant oil equalization piping connection pipe	ø9.52(Flare)				
L	Carrying in or hole for hanging	180x44.7				
N	Refrigerant piping exit hole	ø88(or ø100)				

Installation example		
Dimensions	1	2
L ₁	500	Open
L ₂	10	10
L ₃	100	100
L ₄	10	Open
H ₁	1500	–
H ₂	No limited	No limited
H ₃	1000	No limited
H ₄	No limited	–

Notes:

- (1) Make sure to secure the unit with anchor bolts.
- (2) Make sure to allow the space of 2m or more above the unit.
- (3) Connect the refrigerant piping (suction gas side, discharge gas side, liquid side) at local site.
- (4) The refrigerant piping connection entrance and the power supply intake are of the half blank shape. Cut it with the nipper etc., when you use.
- (5) Use ø88 (or ø100) for the refrigerant piping connection entrance.
- (6) Please use the anchor hole (M10x10) marked I and J and M for a renewal purpose.
- (7) Please connect the oil equalization pipe marked K with only the outdoor combination unit.
- (8) Please use combination trestle (option) when you use the trestle by outdoor combination unit.



KXR6 Outdoor units

Heat recovery 3-pipe combination systems 26, 28, 30, 32hp (73.5kW – 90.0kW) for simultaneous heating and cooling

Model No.	Nominal Cooling Capacity
FDC735KXRE6 (FDC335-K+FDC400)	73.5kW
FDC800KXRE6 (FDC400x2)	80.0kW
FDC850KXRE6 (FDC400+FDC450)	85.0kW
FDC900KXRE6 (FDC450x2)	90.0kW

- The KXR6 heat recovery systems offer high performance VRF for almost every type of building, with the capacity for simultaneous heating and cooling operations of individual indoor units. Energy efficiency is maximised by employing DC inverter compressors ONLY, and distributing surplus heat from cooling operations to areas where it is required (and vice versa) resulting in COP (in cooling) from 3.3 to 3.5.
- Connect from 50% up to 160% capacity indoor units.
- Industry leading total piping length up to 1000m and a maximum pipe run of 160m.



Uniform footprint of all models (from 8hp-24hp) allows continuous side-by-side installation

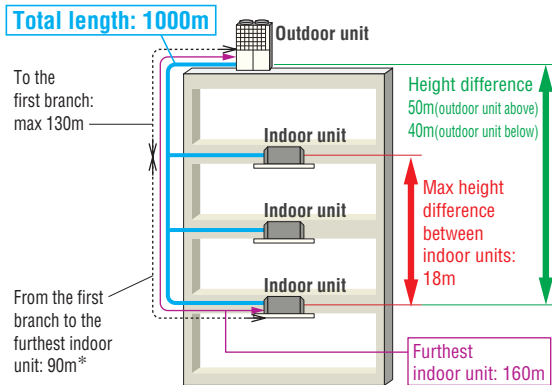

* The difference between the longest and the shortest indoor unit piping from the first branch must be within 40m.

Range of operation

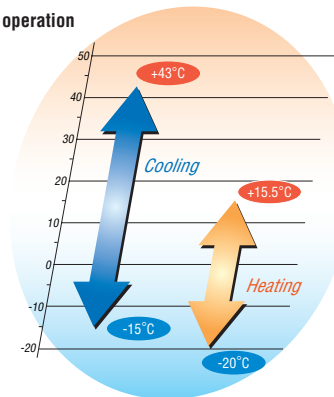

Specifications

Item			FDC735KXRE6	FDC800KXRE6	FDC850KXRE6	FDC900KXRE6	
Combination (FDC)			335KXRE6-K 400KXRE6	400KXRE6 400KXRE6	400KXRE6 450KXRE6	450KXRE6 450KXRE6	
Nominal horse power			26HP	28HP	30HP	32HP	
Power source			3 Phase 380-415V, 50Hz				
Nominal capacity	Cooling	kW	73.5	80.0	85.0	90.0	
	Heating	kW	82.5	90.0	95.0	100.0	
Electrical characteristics			16				
Electrical characteristics	Starting current	A	16				
	Power consumption	Cooling	kW	21.08	23.22	25.10	26.98
		Heating	kW	21.3	23.86	25.25	26.64
Operating current	Cooling	A	34.4-31.5	38.0-34.8	40.6-37.2	43.2-39.6	
	Heating	A	35.4-32.4	39.8-36.4	41.9-38.3	44.0-40.2	
Exterior dimensions		HxWxD	mm 1690x2700x720				
Net weight		kg	674				
Refrigerant charge		R410A	kg 33				
Refrigerant piping size		Liquid line	ø15.88(5/8")				
		Suction Gas line	ø31.75(1 1/4") [ø34.92(1 3/8")]				
		Discharge Gas line	ø25.4(1") [ø28.58(1 1/8")]		ø28.58(1 1/8")		
Capacity connection		%	50~160				
Number of connectable indoor units			53	58	61	65	

1. The data are measured under the following conditions (ISO-T1). Cooling: Indoor temp. of 27°CDB, 19°CWB, and outdoor temp. of 35°CDB. Heating: Indoor temp. of 20°CDB, and outdoor temp. of 7°CDB, 6°CWB. Piping length is 7.5m.
 2. Sound pressure level indicates the value in an anechoic chamber. During operation these values are somewhat higher due to ambient conditions.
 3. [] : Pipe sizes applicable to European installations are shown in parentheses.

Dimensions

All measurements in mm.

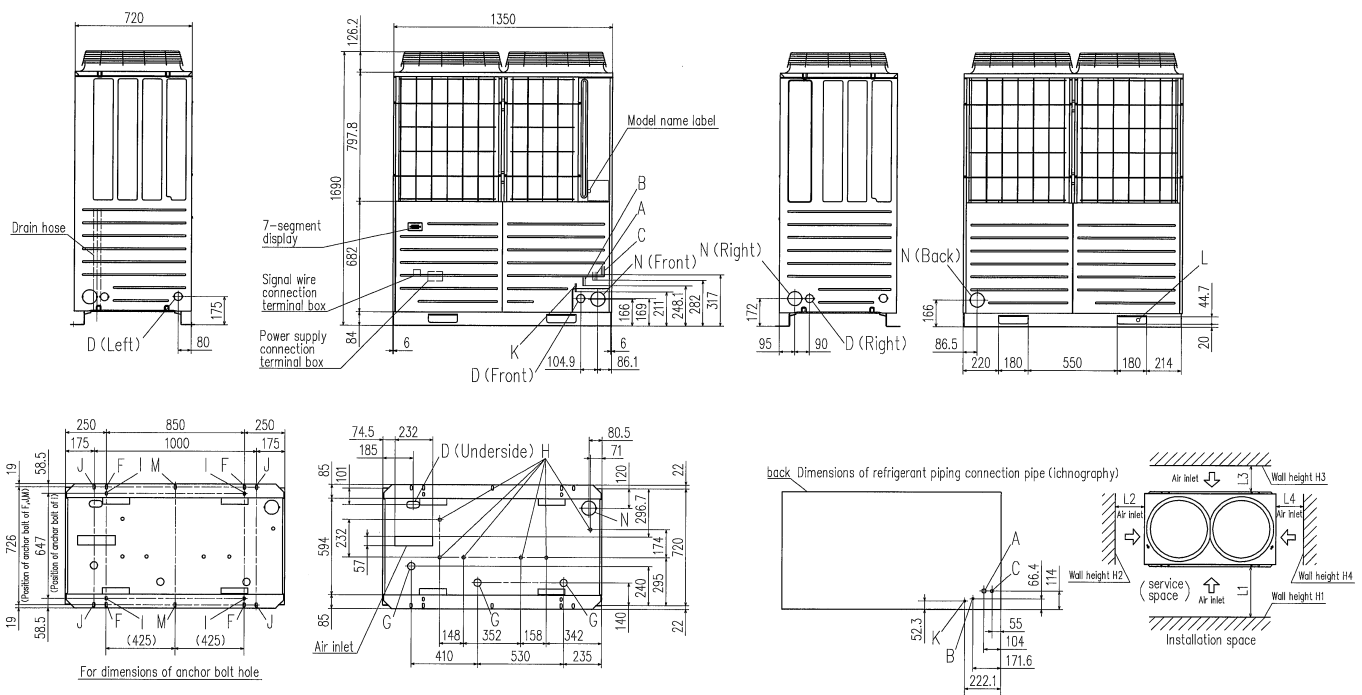

Mark	Content	335-K	400	450
A	Refrigerant suction gas piping connection entrance	ø25.4(Brazing)		ø28.58(Brazing)
B	Refrigerant liquid piping connection entrance	ø12.7(Flare)		
C	Refrigerant discharge gas piping connection entrance	ø19.05(Brazing)	ø22.22(Brazing)	
D	Power supply entry hole	ø50(right · left · front),long hole 40x80(under side)		
F	Anchor bolt hole	M10 x 4 places		
G	Drain waste water hose hole	ø45 x 3 places		
H	Drain hole	ø20 x 6 places		
K*	Refrigerant oil equalization piping connection entrance	ø9.52(Flare)		
L	Carrying in or hole for hanging	180x44.7		
N	Refrigerant piping exit hole	ø88(or ø100)		

*14,16HP models only

Notes:

- (1) Make sure to secure the unit with anchor bolts.
- (2) Make sure to allow the space of 2m or more above the unit.
- (3) Connect the refrigerant piping (suction gas side, discharge gas side, liquid side) at local site.
- (4) The refrigerant piping connection entrance and the power supply intake are of the half blank shape. Cut it with the nipper etc., when you use.
- (5) Use ø88 (or ø100) for the refrigerant piping connection entrance.
- (6) Please use the anchor hole (M10x10) marked I and J and M for a renewal purpose.
- (7) Please connect the oil equalization pipe marked K with only the outdoor combination unit. (for 14,16HP only)
- (8) Please use combination trestle (option) when you use the trestle by outdoor combination unit. (for 14,16HP only)

Installation example		
Dimensions	1	2
L ₁	500	Open
L ₂	10	10
L ₃	100	100
L ₄	10	Open
H ₁	1500	-
H ₂	No limited	No limited
H ₃	1000	No limited
H ₄	No limited	-



KXR6 Outdoor units

Heat recovery 3-pipe combination systems

34, 36, 38, 40, 42, 44, 46, 48hp (96.0kW – 136.0kW)

for simultaneous **heating** and **cooling**



Model No.	Nominal Cooling Capacity
FDC960KXRE6 (FDC450+FDC504)	96.0kW
FDC1010KXRE6 (FDC504x2)	101.0kW
FDC1065KXRE6 (FDC504+FDC560)	106.5kW
FDC1130KXRE6 (FDC560x2)	113.0kW
FDC1180KXRE6 (FDC560-K+FDC615)	118.0kW
FDC1235KXRE6 (FDC615x2)	123.5kW
FDC1300KXRE6 (FDC615+FDC680)	130.0kW
FDC1360KXRE6 (FDC680x2)	136.0kW



- The KXR6 heat recovery systems offer high performance VRF for almost every type of building, with the capacity for simultaneous heating and cooling operations of individual indoor units. Energy efficiency is maximised by employing DC inverter compressors ONLY, and distributing surplus heat from cooling operations to areas where it is required (and vice versa) resulting in COP (in cooling) from 3.3 to 3.8.
- Connect from 50% up to 130% capacity indoor units (960KXRE6:160%).
- Industry leading total piping length up to 1000m and a maximum pipe run of 160m.

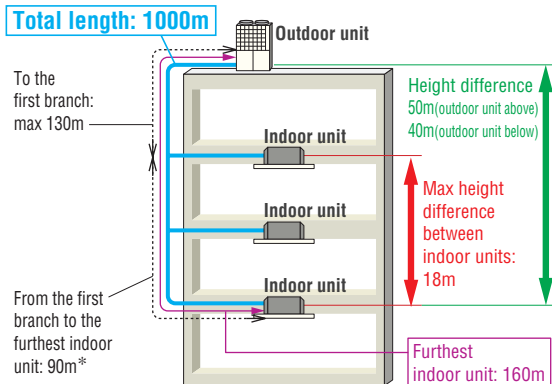

*The difference between the longest and the shortest indoor unit piping from the first branch must be within 40m.

Range of operation

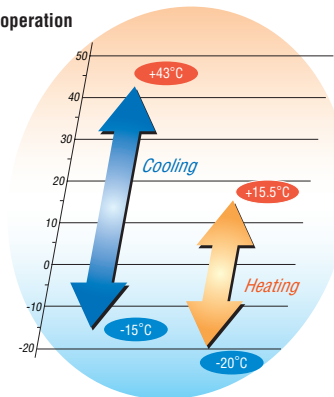

Specifications

Item		FDC960KXRE6	FDC1010KXRE6	FDC1065KXRE6	FDC1130KXRE6	FDC1180KXRE6	FDC1235KXRE6	FDC1300KXRE6	FDC1360KXRE6	
Combination (FDC)		450KXRE6	504KXRE6	504KXRE6	560KXRE6	560KXRE6-K	615KXRE6	615KXRE6	680KXRE6	
		504KXRE6	504KXRE6	560KXRE6	560KXRE6	615KXRE6	615KXRE6	680KXRE6	680KXRE6	
Nominal horse power		34HP	36HP	38HP	40HP	42HP	44HP	46HP	48HP	
Power source		3 Phase 380-415V, 50Hz								
Nominal capacity	Cooling	96.0	101.0	106.5	113.0	118.0	123.5	130.0	136.0	
	Heating	108.0	113.0	119.5	127.0	132.0	138.0	142.0	146.0	
Electrical characteristics	Starting current	A 16								
	Power consumption	Cooling	28.67	30.36	33.13	35.9	39.42	42.94	47.46	51.98
		Heating	28.44	30.24	31.91	33.58	35.9	38.22	38.80	39.38
	Operating current	Cooling	45.4-41.6	47.6-43.6	52.2-47.8	56.8-52.0	63.1-57.8	69.4-63.6	79.6-72.9	89.8-82.2
Heating		47.2-43.2	50.4-46.2	53.2-48.8	56.0-51.4	59.6-54.6	63.2-57.8	65.6-60.0	68.0-62.2	
Exterior dimensions	HxWxD	mm 2048x2700x720								
Net weight	kg	698	722			750				
Refrigerant charge	R410A	kg 33								
Refrigerant piping size	Liquid line	ø15.88(5/8")			ø19.05(3/4")					
	Suction Gas line	in (mm) ø1.75(1 1/4") [ø4.92(1 3/8")]								
	Discharge Gas line	ø38.1(1 1/2") [ø34.92(1 3/8")]								
Capacity connection	%	50-160				50-130				
Number of connectable indoor units		69	59	62	66	69	72	76	80	

1. The data are measured under the following conditions(ISO-T1). Cooling: Indoor temp. of 27°CDB, 19°CWB, and outdoor temp. of 35°CDB. Heating: Indoor temp. of 20°CDB, and outdoor temp. of 7°CDB, 6°CWB. Piping length is 7.5m.
 2. Sound pressure level indicates the value in an anechoic chamber. During operation these values are somewhat higher due to ambient conditions.
 3. [] : Pipe sizes applicable to European installations are shown in parentheses.

Dimensions

All measurements in mm.

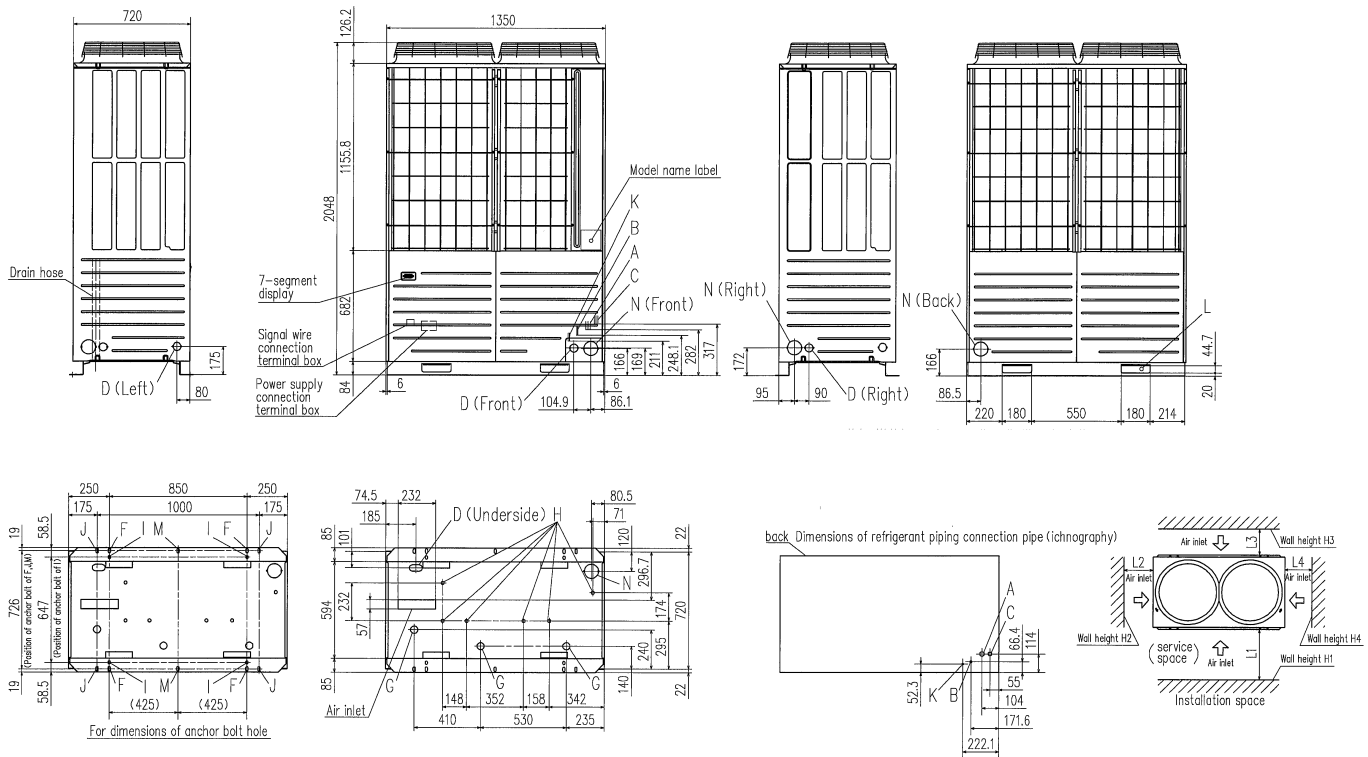

Mark	Content	504	560	560-K	615	680
A	Refrigerant suction gas piping connection entrance			ø28.58(Brazing)		
B	Refrigerant liquid piping connection entrance			ø12.7(Flare)		
C	Refrigerant discharge gas piping connection entrance	ø22.22(Brazing)		ø25.4(Brazing)		
D	Power supply entry hole	ø50(right · left · front),long hole 40x80(under side)				
F	Anchor bolt hole	M10 x 4 places				
G	Drain waste water hose hole	ø45 x 3 places				
H	Drain hole	ø20 x 6 places				
K	Refrigerant oil equalization piping connection pipe	ø9.52(Flare)				
L	Carrying in or hole for hanging	180x44.7				
N	Refrigerant piping exit hole	ø88(or ø100)				

Installation example		
Dimensions	1	2
L ₁	500	Open
L ₂	10	10
L ₃	100	100
L ₄	10	Open
H ₁	1500	-
H ₂	No limited	No limited
H ₃	1000	No limited
H ₄	No limited	-

Notes:

- (1) Make sure to secure the unit with anchor bolts.
- (2) Make sure to allow the space of 2m or more above the unit.
- (3) Connect the refrigerant piping (suction gas side, discharge gas side, liquid side) at local site.
- (4) The refrigerant piping connection entrance and the power supply intake are of the half blank shape. Cut it with the nipper etc., when you use.
- (5) Use ø88 (or ø100) for the refrigerant piping connection entrance.
- (6) Please use the anchor hole (M10x10) marked I and J and M for a renewal purpose.
- (7) Please connect the oil equalization pipe marked K with only the outdoor combination unit.
- (8) Please use combination trestle (option) when you use the trestle by outdoor combination unit.



KXR6 PFD refrigerant flow branch control

Branch control

- PFD1123-E
- PFD1803-E
- PFD2803-E
- PFD1123X4-E

Total downstream indoor unit capacity

- less than 11.2kW
- less than 18.0kW
- 28.0kW or less
- less than 44.8kW(less than 11.2kWx4 branches)

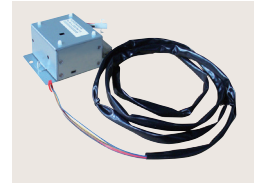

Relay kit
(Relay kit comes attached to the branch control)

- The remote control setting (as individual indoor unit on-off, temperature setting other than cooling/heating mode control) is possible with one remote control connected to each indoor unit, while at the same time, Center Control (SC-SL1N/2NA/3NA-E) can be used together with the individual remote control.
- It is necessary to set the central control to use this function. Please refer to the Installation Manual for details.

- In case of the mode changeover from cooling to heating and from cooling to heating, by the use of only the indoor units and PFD box combination, the mode changeover sound was reduced. All this made possible without turning off the compressor and at the same time without the reduction of capacity.

- The risk of refrigerant leakage was reduced by changing piping connection at the PFD box to brazing method.

- By the use of optional PFD box extension cable that has a connector at ends, makes it possible to further separate the indoor unit and PFD box. This will enable the PFD box to be located away from the indoor unit and help reduce the influence of sound caused by PFD box and refrigerant flow.

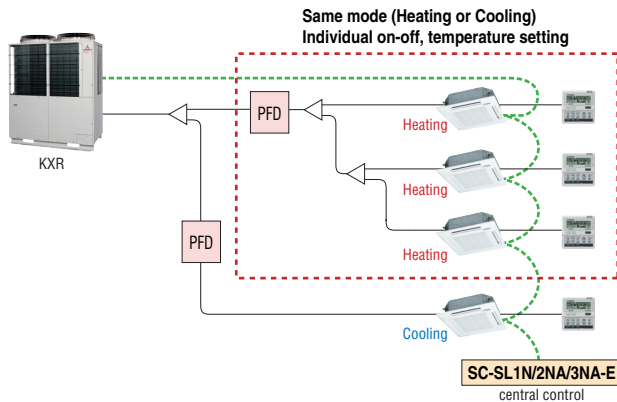

extension cable 15m



PFD-15WR-E (option)

Easy installation

New PFD design means the connection of the indoor unit liquid pipe is made directly to the liquid line - bypassing the PFD. This means (x2) less pipe connections per indoor unit, reducing installation time and cost.

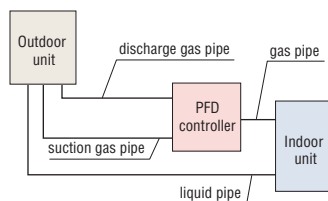

The PFD is connected to the indoor unit by 3 core signal wire via a relay kit (supplied) to be located within 2m of each other. The indoor unit however can be up to 40m away. Power to the PFD can be connected from the indoor unit or other supply.

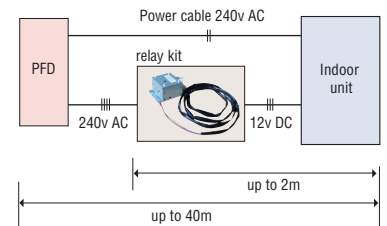

Groups of indoor units can be connected up to a total capacity 44.8kW to a single PFD with branch piping and all units in that group will operate in the same mode only (cooling or heating).

We also have introduced the 4-way PFD control PFD1123X4-E which can connect up to four indoor units with individual control - simultaneous cooling or heating.



4-Way PFD box

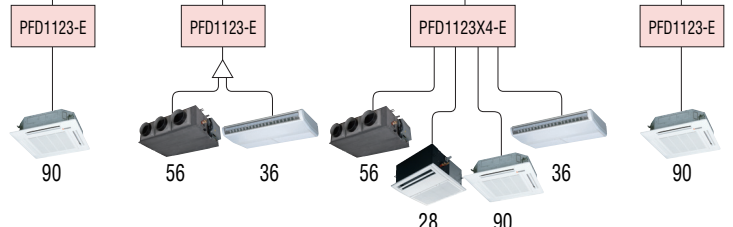

Branch control	Total downstream capacity	*Connectable indoor units
PFD1123-E	less than 11.2kW	1-5
PFD1803-E	less than 18.0kW	1-8
PFD2803-E	28.0kW or less	1-10
PFD1123X4-E	less than 44.8kW(less than 11.2kWx4 branches)	Up to 16

*Refer to Data Book for details

Dimensions

All measurements in mm.

PFD1123-E

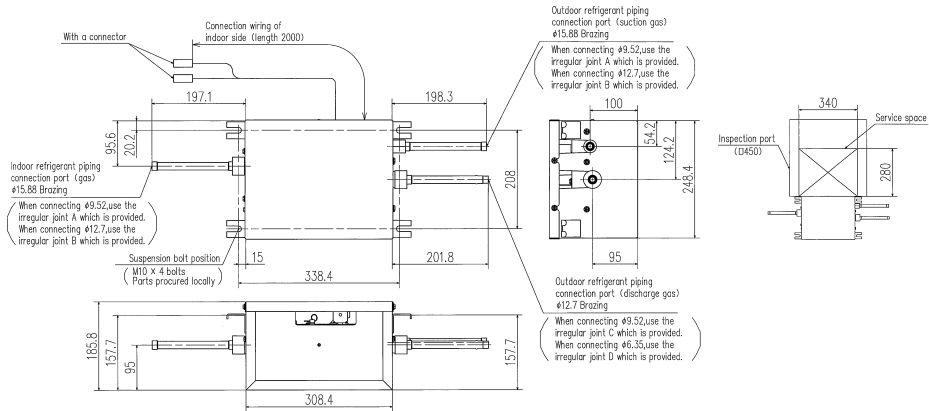

PFD1803-E

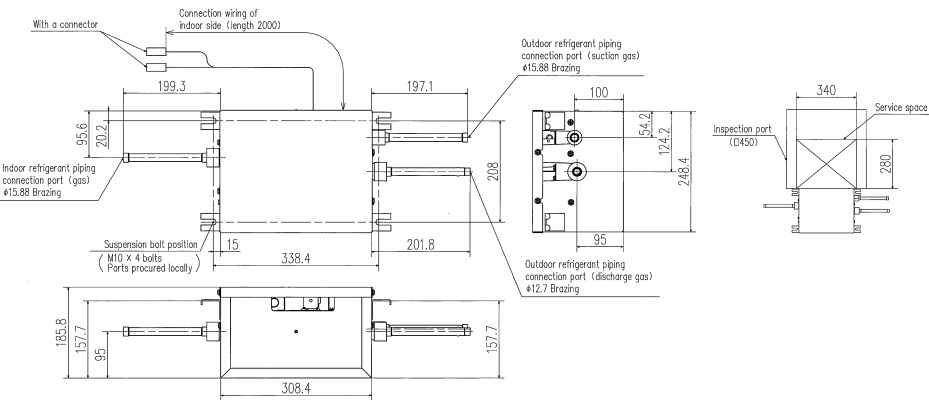

PFD2803-E

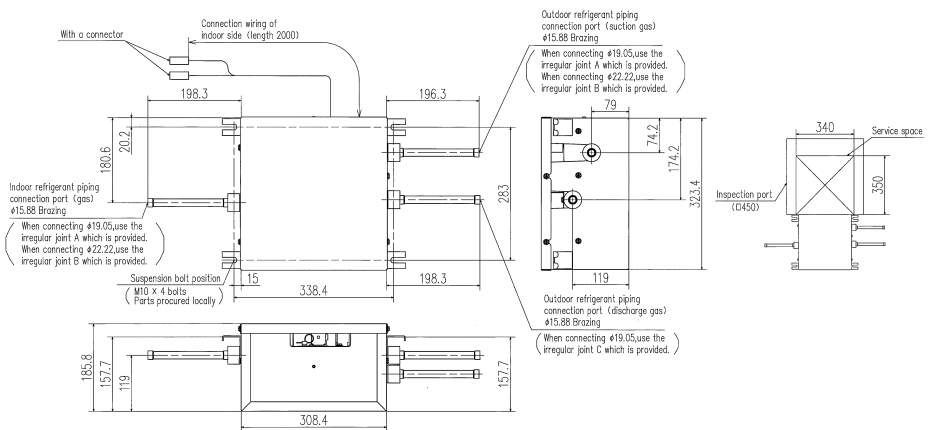

PFD1123X4-E

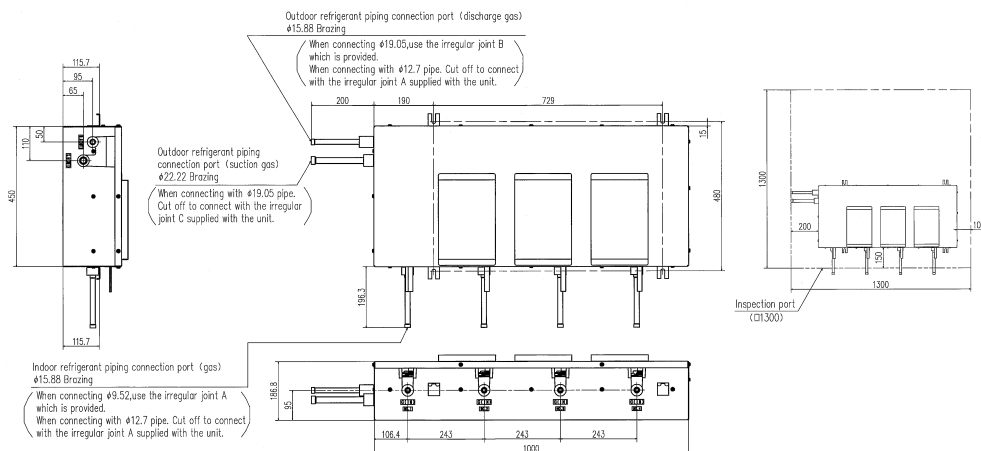



KXR6 refrigerant piping

Installation of Interconnecting Pipework

Mitsubishi KXR6 equipment is manufactured to the highest standards of quality and reliability. It is imperative the method of installation and the materials used are also to high standards, to ensure trouble free operation and long term reliability.

The interconnecting pipework must be installed by a competent and trained engineer.

Refrigeration quality copper tube must be used, soft copper coils or half-hard straight lengths.

The refrigeration quality tube must be soft drawn seamless high grade copper pipe. The copper tube must be selected taking into account the higher operating pressures of R410A refrigerant, and that high pressures will occur throughout the system because of the reverse cycle operation. All pipework material used should be EN12735 European standard.

The supplied branch pipe kits, must be used to make connections to indoor units, and the supplied manifold kits must be used to make connections between outdoor units (where applicable); it is not permitted to use standard fittings such as elbows, tees etc. The branch pipes shall be installed in accordance with the manufacturer's instructions, allowing unrestricted flow of refrigerant, and in accordance with European standard E378:2000. All brazed joints shall be made with dry nitrogen purge to ensure the prevention of oxidation to the internal surface of the copper pipes.

The ingress of moisture, dirt and any other contaminants to the interior of the copper pipes, and air conditioning units, must be prevented during the installation procedure. After the installation of pipework, prior to the

connection of the outdoor units, and sealing of insulation joints, the pipework must be pressure tested for leakage, using dry nitrogen.

Additional Refrigerant

Additional R410A refrigerant only shall be used, and must be charged by weight only, using electronic scales. The amount of additional refrigerant must be accurately calculated from the manufacturer's data, based on the length and diameter of each section of the liquid refrigerant pipework of the system.

Single outdoor unit piping examples:

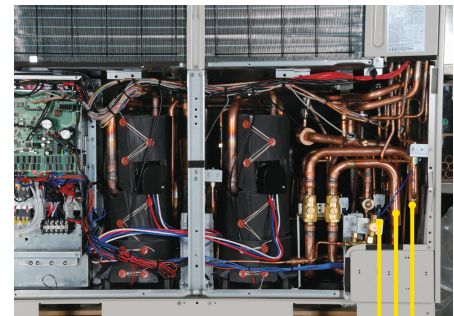
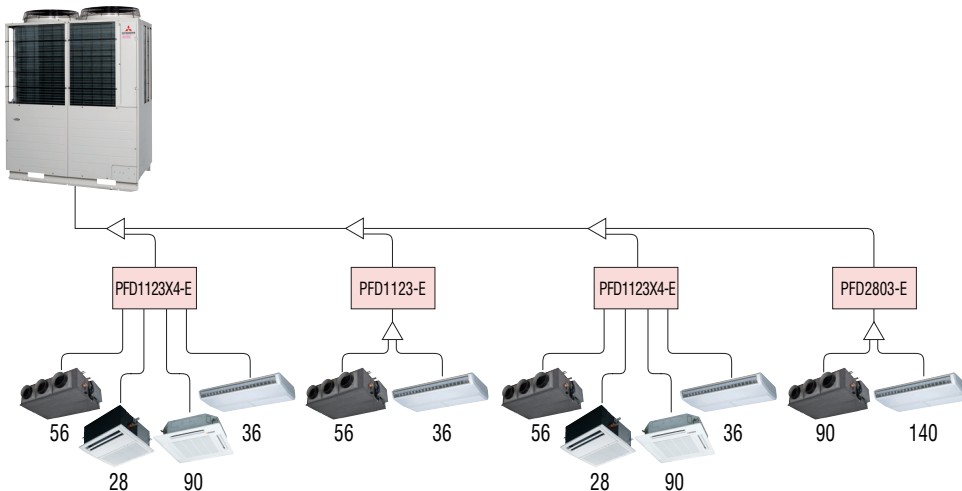
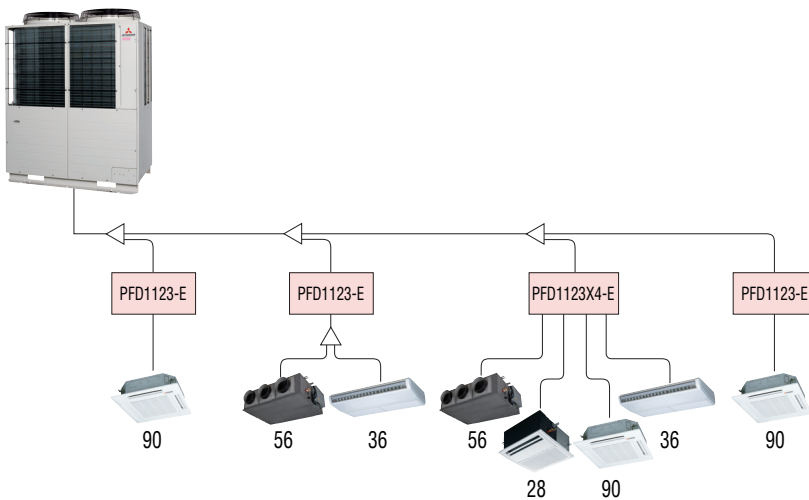

Liquid pipe
Suction gas pipe
Discharge gas pipe

KXR6 refrigerant piping

Pipe sizes applicable to European installations.

Outdoor unit (HP)	8	10	12	14	16	18	20	22	24	26	28	30	32	34	36	38	40	42	44	46	48
Liquid pipe	ø9.52		ø12.7						ø15.88						ø19.05						
Suction Gas pipe	ø19.05		ø22.22		ø28.58						ø34.92										
Discharge Gas Pipe	ø15.88		ø19.05		ø22.22						ø28.58										
Liquid pipe	ø12.7				ø15.88				ø19.05				ø22.22								
Suction Gas pipe	ø22.22				ø28.58				ø34.92												
Discharge Gas Pipe	ø15.88		ø19.05		ø22.22						ø28.58										

mm	inch	mm	inch
ø9.52	3/8"	ø28.58	1 1/8"
ø12.7	1/2"	ø31.8	1 1/4"
ø15.88	5/8"	ø34.92	1 3/8"
ø19.05	3/4"	ø38.1	1 1/2"
ø22.22	7/8"	ø44.5	1 3/4"
ø25.4	1"	ø50.8	2"

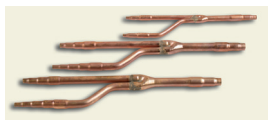

DIS-22-1-R/DIS-180-1-R



DOS-2A-1-R

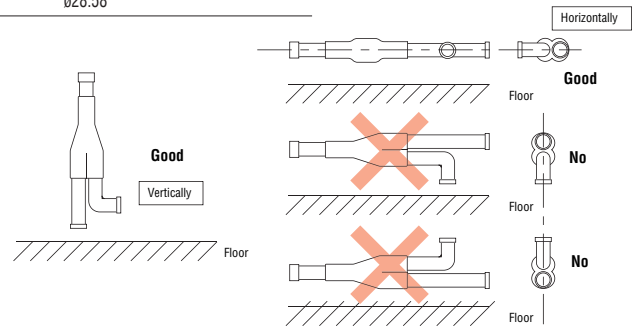

Oil equalisation pipe(1)
Outdoor unit branch pipe set (DOS-2A-1-R)

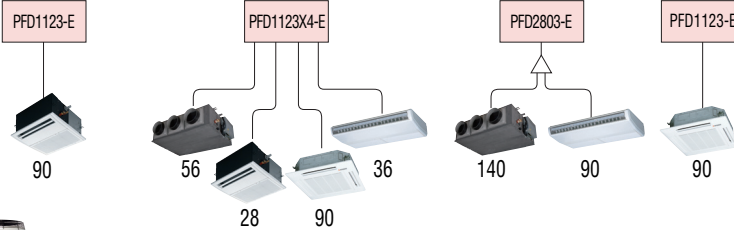

Oil equalisation pipe(1)
Outdoor unit branch pipe set (DOS-2A-1-R)

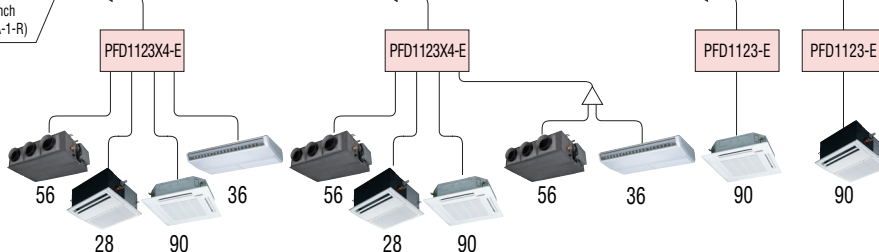

Outdoor unit's branching piping

Outdoor unit	Branch piping set
2 units (for 735~1360)	DOS-2A-1-R

Indoor unit's first branching piping

Total capacity of indoor units	Branch piping set
~179	DIS-22-1-R
180~370	DIS-180-1-R
371~539	DIS-371-2-R
540~	DIS-540-2-R

For Down Stream of PFD box

Total capacity of indoor units	Branch piping set
~179	DIS-22-1
180~370	DIS-180-1
371~539	DIS-371-1



KXR6 electrical wiring – power supply

KXR6 new design includes greatly simplified wiring requirements utilising a ‘polarity-free’ two wire control loop connecting the indoor units.

Power wiring

Cables can be laid through the front, right, left or bottom of the outdoor unit casing.

Separate power supplies should be used for the outdoor unit (3/phase) and the indoor units (1/phase).

Only control wiring is connected from outdoor to indoor unit.

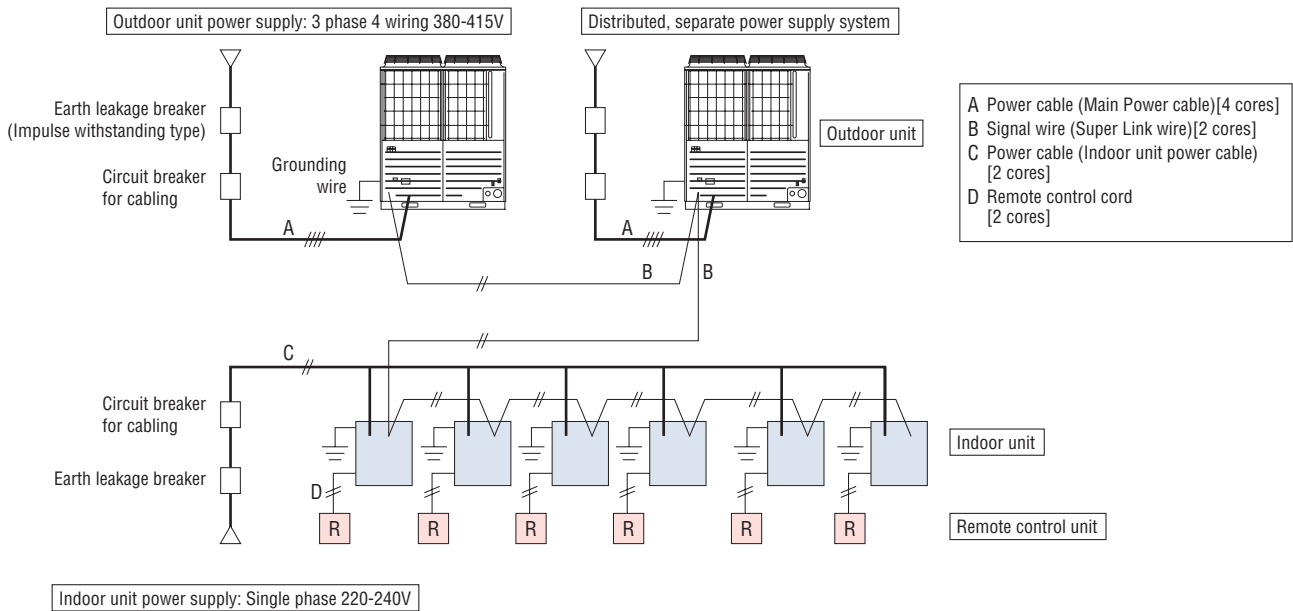

CAUTION

If the earth leakage breaker is exclusively for ground fault protection, then you will need to install a circuit breaker for wiring work.

KXR6 outdoor unit mechanical compartment

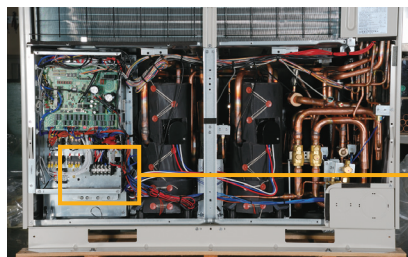

Electrical component box

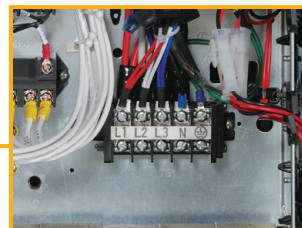

Outdoor unit power supply terminal block

KXR6 electrical wiring – control wiring

1. The control wiring is 5 Volt DC, non-polarised, two wire connection notated as 'A1' and 'B1'. This 'AB' wiring connects outdoor unit to indoor unit and indoor unit to indoor unit.

2. This wiring must be a 2-core shielded cable size 0.75mm² or 1.25mm².

	0.75mm ²	1.25mm ²
~1000m	YES	YES
1000~1500m	YES	NO

3. We recommend the both ends of the shield of the cable are connected to ground (earth) at all the indoor units and outdoor units.

4. When plural outdoor units are used,
 • Connect the signal cable between indoor and outdoor units and the signal cable between outdoor units belonging to the same refrigerant line to A1 and B1.
 • Connect the signal line between outdoor units on different refrigerant lines to A2 and B2.

5. For current specification of 2-core (AB) wiring, please consult your MHI dealer.

(1) When one outdoor unit is used

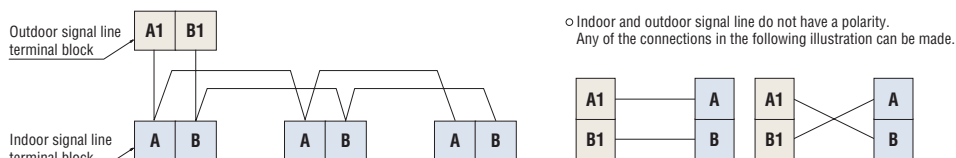

(2) When plural outdoor units are used

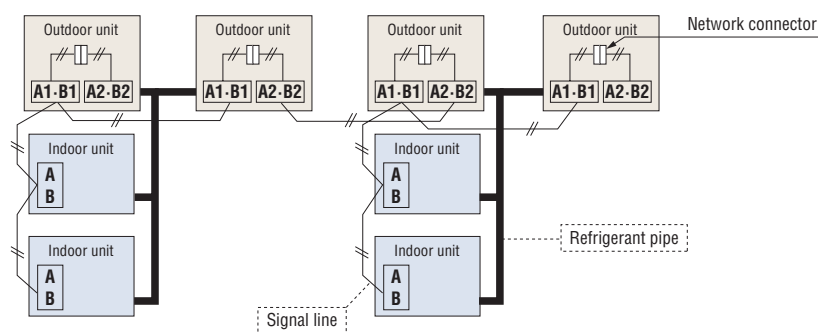

- (a) The maximum number of indoor units that can be connected in a system is 128 and it is possible to configure outdoor units and/or indoor units as an outdoor or indoor unit group connected with each other with two wires.
- (b) The signal wires can also be connected using the method shown below.

(3) The signal lines can also be connected using the method shown below.

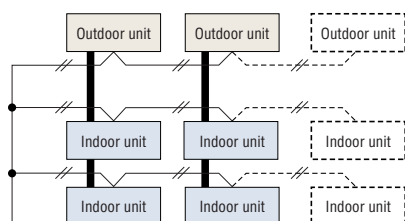

Important

○ Loop wiring prohibited

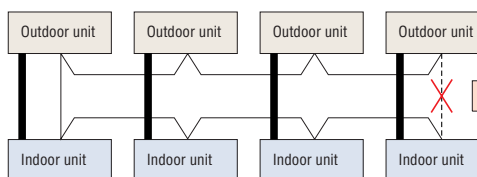

The signal lines cannot form a loop, so the wirings shown as ----- in the diagram are prohibited.

Remote control wiring specifications

For interconnecting wiring between the remote control and indoor units (XY wiring) use 2-core cable size 0.3mm². The maximum length of 2-core cable is 600 metres. Where the 2-core wiring exceeds 100m, use the wire size detailed on the table opposite.

Length (m)	Wire size
100 to 200	0.5mm ² x 2 core
To 300	0.75mm ² x 2 core
To 400	1.25mm ² x 2 core
To 600	2.0mm ² x 2 core

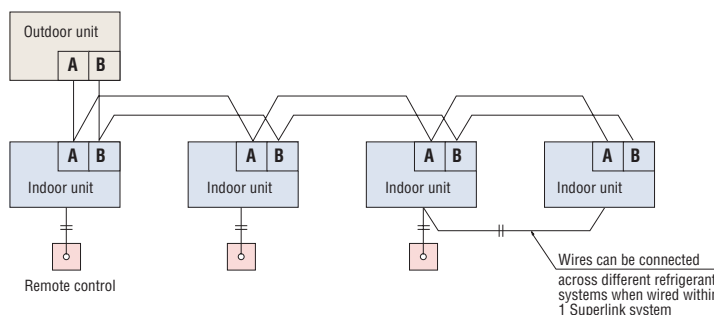



Indoor units Ceiling Cassette -4way- FDT



Model No.

- | | |
|------------|-------------|
| FDT28KXE6D | FDT90KXE6D |
| FDT36KXE6D | FDT112KXE6D |
| FDT45KXE6D | FDT140KXE6D |
| FDT56KXE6D | FDT160KXE6D |
| FDT71KXE6D | |

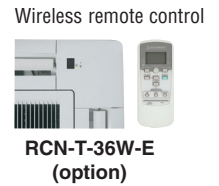
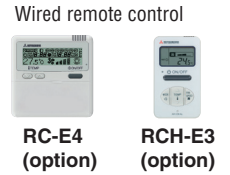

Individual flap control system

According to room temperature conditions, four directions of air flow can be controlled by individual flap as preferred. As individual flap control is available even after installation, installation area became wider than before.



Due to optimization of outlet design of air flow with our new advanced technology, sufficient air flow is secured and long reach of air flow is realized.

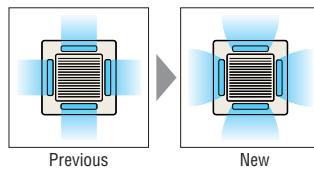

The thinnest design

Thanks to new design of heat exchanger changed from 2 parts to 1 part, the height of indoor unit is reduced drastically. Furthermore applying DC fan motors to FDT models, the highest energy efficiency level, reduction of weight and significant compact design are realized.

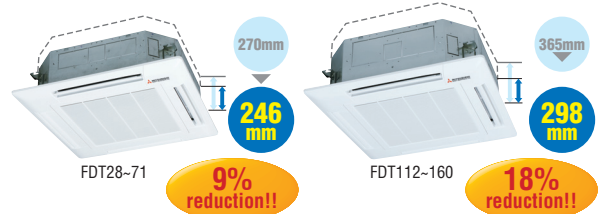
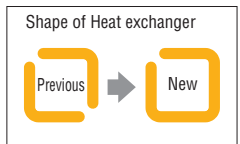

Flap control system

Selection of flap position is possible. Individual flaps can be set at different angles.

*RCH-E3 is not applicable to the Individual flap control system and the Flap control system.

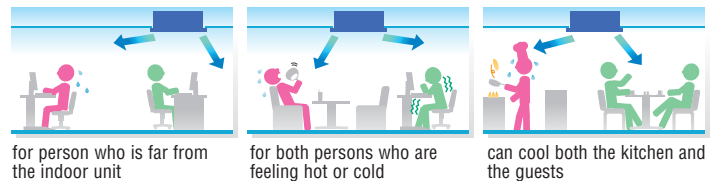
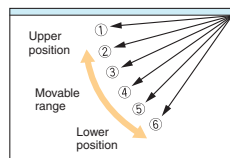

Specifications

Item	Model	FDT28KXE6D	FDT36KXE6D	FDT45KXE6D	FDT56KXE6D	FDT71KXE6D	FDT90KXE6D	FDT112KXE6D	FDT140KXE6D	FDT160KXE6D	
Nominal cooling capacity	kW	2.8	3.6	4.5	5.6	7.1	9.0	11.2	14.0	16.0	
Nominal heating capacity	kW	3.2	4.0	5.0	6.3	8.0	10.0	12.5	16.0	18.0	
Power source		1 Phase 220-240V, 50Hz									
Power consumption	Cooling	0.03-0.03			0.04-0.04	0.10-0.10	0.14-0.14				
	Heating	0.03-0.03			0.04-0.04	0.10-0.10	0.14-0.14				
Sound pressure level ※	dB(A)	Hi:33 Me:31 Lo:30			Hi:33 Me:31 Lo:30	Hi:33 Me:31 Lo:30	Hi:40 Me:37 Lo:35	Hi:42 Me:40 Lo:37			Hi:43 Me:41 Lo:38
Exterior dimensions H x W x D	mm	Unit:246x840x840 Panel:35x950x950					Unit:298x840x840 Panel:35x950x950				
Net weight	kg	Unit:22 Panel:5.5			Unit:24 Panel:5.5		Unit:27 Panel:5.5				
Air flow ※	CMM	Hi:18 Me:16 Lo:14				Hi:18 Me:16 Lo:14		Hi:27 Me:24 Lo:20		Hi:30 Me:27 Lo:23	
Outside air intake		Possible									
Panel		T-PSA-3AW-E									
Air filter, Q'ty		Pocket Plastic net x1 (Washable)									
Remote control(option)		wired:RC-E4, RCH-E3 wireless:RCN-T-36W-E									
Installation data	mm(in)	Liquid line:ø6.35(1/4") Gas line:ø9.52(3/8")		Liquid line:ø6.35(1/4") Gas line:ø12.7(1/2")			Liquid line:ø9.52(3/8") Gas line:ø15.88(5/8")				

1. The data are measured under the following conditions(ISO-T1). Cooling: Indoor temp. of 27°CDB, 19°CWB, and outdoor temp. of 35°CDB. Heating: Indoor temp. of 20°CDB, and outdoor temp. of 7°CDB, 6°CWB.
2. Sound pressure level indicates the value in an anechoic chamber. During operation these values are somewhat higher due to ambient conditions.

※ Powerful-Hi can be selected. Sound pressure level: FDT28/36/45 37dB(A), FDT56 39dB(A), FDT71 46dB(A), FDT90/112/140/160 51dB(A). Air flow: FDT28/36/45/56 20CMM, FDT71 28CMM, FDT90/112/140/160 37CMM.

Dimensions

All measurements in mm.

FDT28KXE6D, 36KXE6D, 45KXE6D, 56KXE6D, 71KXE6D

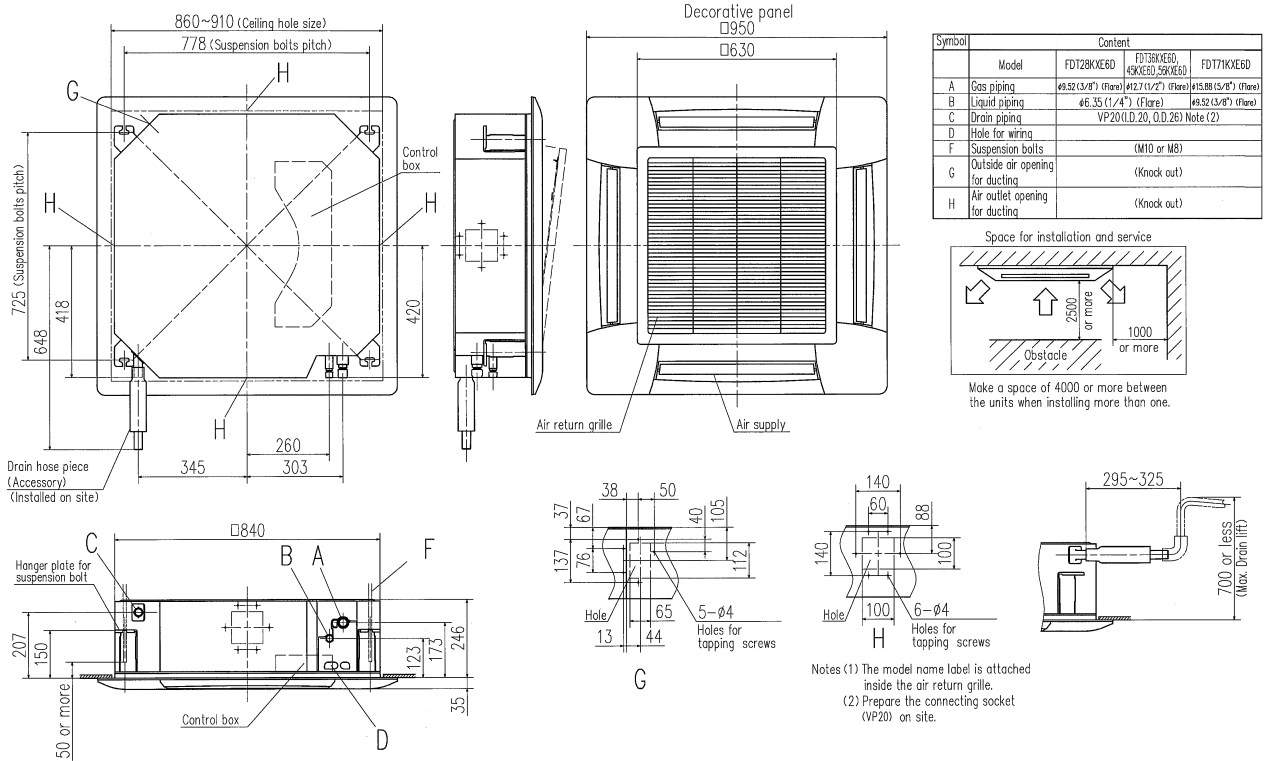

FDT90KXE6D, 112KXE6D, 140KXE6D, 160KXE6D

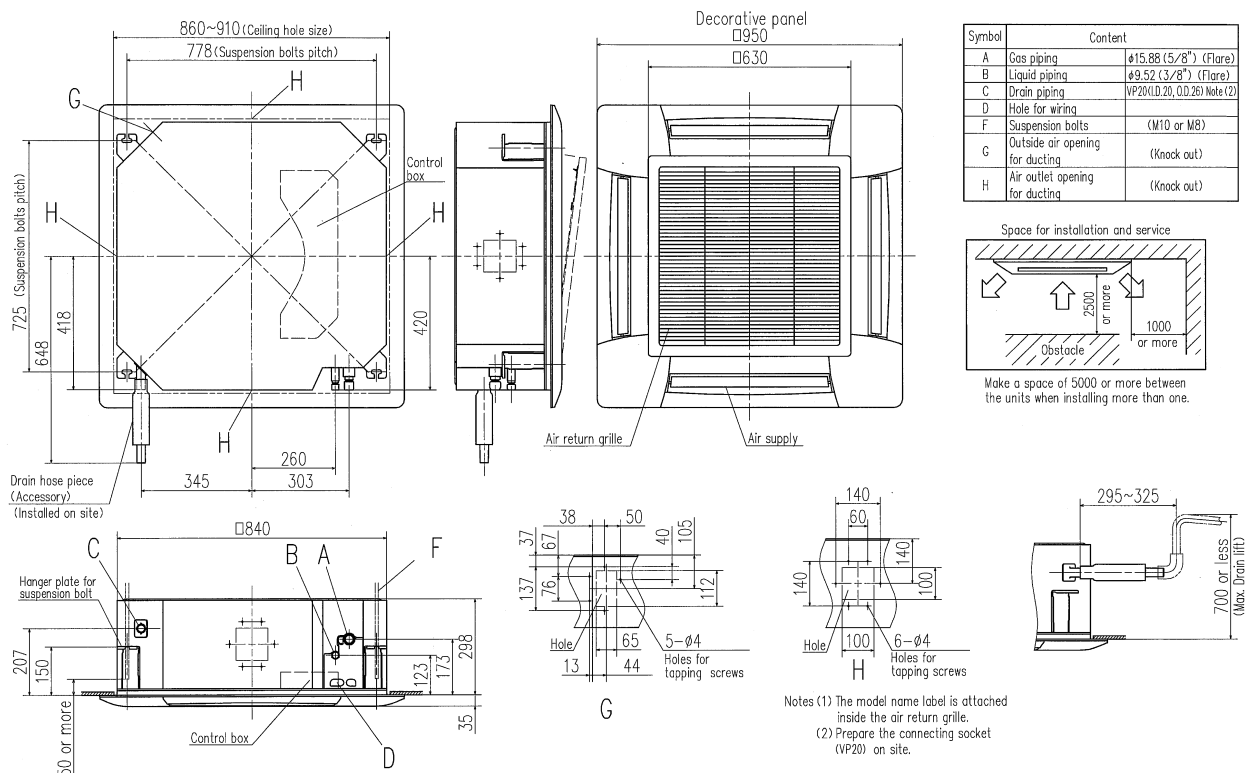



Ceiling Cassette -4way Compact (600x600mm)- FDTC

Model No.

- FDTC22KXE6D
- FDTC28KXE6D
- FDTC36KXE6D
- FDTC45KXE6D
- FDTC56KXE6D

Fits into standard
600 x 600 ceiling



Wired remote control



RC-E4
(option)



RCH-E3
(option)

Wireless remote control



RCN-TC-24W-ER
(option)

Taking OA (Outside Air) into inside NEW

OA Spacer TC-OAS-E (option)
Joint Duct TC-OAD-E (Option)

Utilizing OA spacer which comes as optional equipment, outside air can be taken into inside.

Using 1 joint duct:
OA comes up to 1.3m³/min.
Using 2 joint ducts:
OA comes from 1.3 to
2.6m³/min.

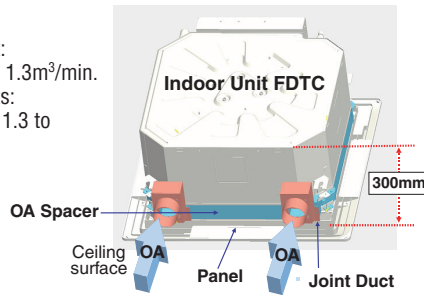

Individual flap control system

According to room temperature conditions, four directions of air flow can be controlled by individual flap as preferred. As individual flap control is available even after installation, installation area became wider than before.



Quiet operation (Sound level in the Lo mode.)

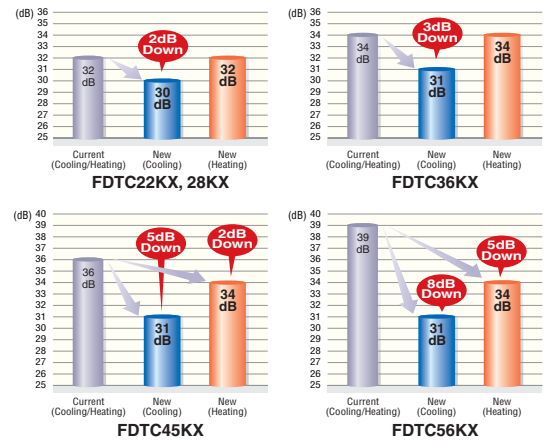

Flap control system

Selection of flap position is possible. Individual flaps can be set at different angles.

*RCH-E3 is not applicable to the Individual flap control system and the Flap control system.

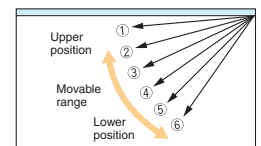

Specifications

Item	Model	FDTC22KXE6D	FDTC28KXE6D	FDTC36KXE6D	FDTC45KXE6D	FDTC56KXE6D
Nominal cooling capacity	kW	2.2	2.8	3.6	4.5	5.6
Nominal heating capacity	kW	2.5	3.2	4.0	5.0	6.3
Power source		1 Phase 220-240V, 50Hz				
Power consumption	Cooling	0.03-0.03			0.04-0.04	
	Heating	0.03-0.03			0.04-0.04	
Sound pressure level **	Cooling	Hi:35 Me:33 Lo:30		Hi:38 Me:36 Lo:31	Hi:40 Me:37 Lo:31	Hi:45 Me:39 Lo:31
	Heating	Hi:35 Me:33 Lo:32		Hi:38 Me:36 Lo:34	Hi:40 Me:37 Lo:34	Hi:45 Me:39 Lo:34
Exterior dimensions	mm	Unit:248x570x570 Panel:35x700x700				
Net weight	kg	Unit:14 Panel:3.5			Unit:15 Panel:3.5	
Air flow **	Cooling	Hi:9.5 Me:8.5 Lo:7		Hi:10 Me:9 Lo:7	Hi:11 Me:9 Lo:7	Hi:13 Me:10 Lo:7
	Heating	Hi:9.5 Me:8.5 Lo:8		Hi:10 Me:9 Lo:8	Hi:11 Me:9 Lo:8	Hi:13 Me:10 Lo:8
Outside air intake		Not possible				
Panel		TC-PSA-25W-E				
Air filter, Q'ty		Pocket Plastic net x1 (Washable)				
Remote control(option)		wired:RC-E4, RCH-E3 wireless:RCN-TC-24W-ER				
Installation data	mm(in)	Liquid line:ø6.35(1/4")			Liquid line:ø6.35(1/4")	
	Refrigerant piping size	Gas line:ø9.52(3/8")			Gas line:ø12.7(1/2")	

1. The data are measured under the following conditions(ISO-T1). Cooling: Indoor temp. of 27°CDB, 19°CWB, and outdoor temp. of 35°CDB. Heating: Indoor temp. of 20°CDB, and outdoor temp. of 7°CDB, 6°CWB.
2. Sound pressure level indicates the value in an anechoic chamber. During operation these values are somewhat higher due to ambient conditions.

* Powerful-Hi can be selected. Sound pressure level: FDTC22/28 44dB(A), FDTC36 46dB(A), FDTC45 48dB(A), FDTC56 49dB(A). Air flow: FDTC22/28 12CMM, FDTC36 13CMM, FDTC45 15CMM, FDTC56 16CMM.

Dimensions

All measurements in mm.

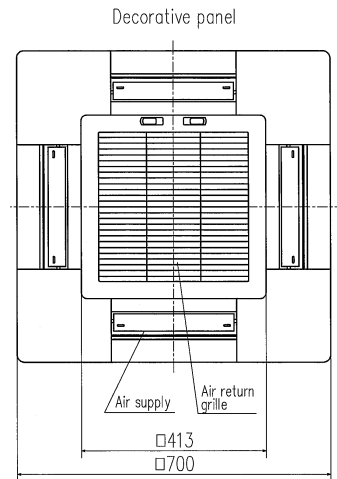
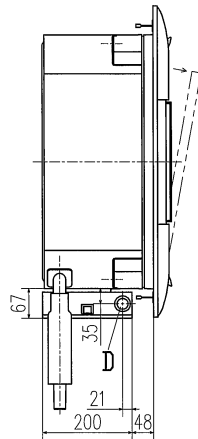
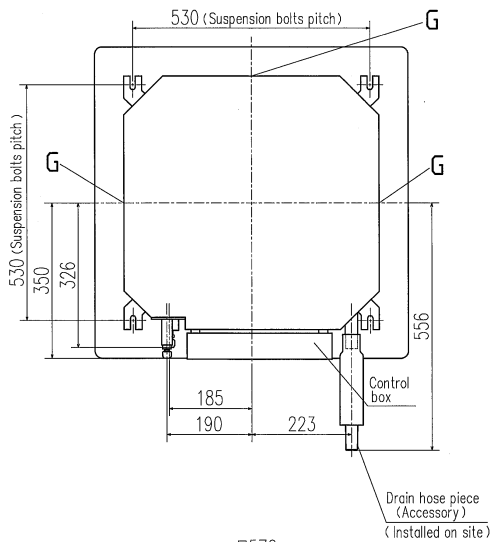

- Notes (1) The model name label is attached on the control box lid.
 (2) Prepare the connecting socket (VP20) on site.
 (3) This unit is designed for 2x2 grid ceiling.
 If it is installed on a ceiling other than 2x2 grid ceiling, provide an inspection part on the control box side.

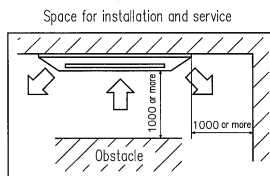
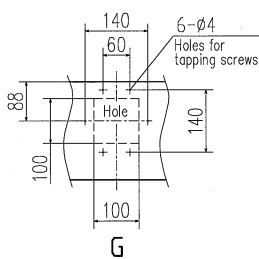
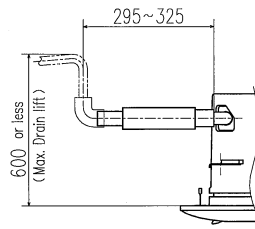
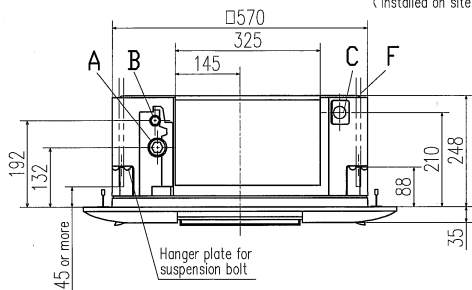

Make a space of 4000 or more between the units when installing more than one.

Symbol	Model	Content
		FDTC22KXE6D, 28KXE6D
		FDTC36KXE6D, 45KXE6D, 56KXE6D
A	Gas piping	φ9.52 (3/8") (Flare) φ12.7 (1/2") (Flare)
B	Liquid piping	φ6.35 (1/4") (Flare)
C	Drain piping	VP20 (I.D.20, O.D.26) Note (2)
D	Hole for wiring	φ25
F	Suspension bolts	(M10 or M8)
G	Air outlet opening for ducting	(Knock out)

Ultra slim design at just 248mm above the ceiling

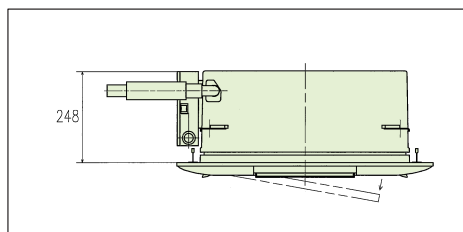

Condensate drain pump included as standard

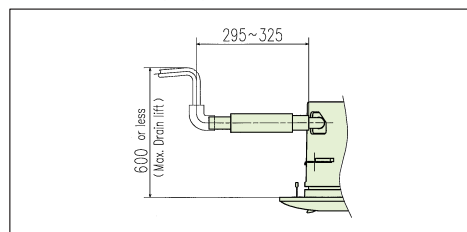



Ceiling Cassette -2way- FDTW

Model No.

- | | |
|-------------|--------------|
| FDTW28KXE6D | FDTW71KXE6D |
| FDTW45KXE6D | FDTW90KXE6D |
| FDTW56KXE6D | FDTW112KXE6D |
| | FDTW140KXE6D |

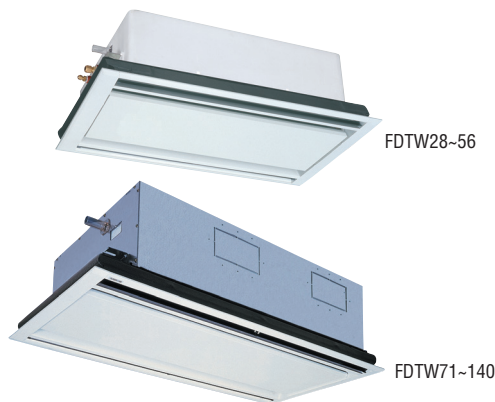

Wired remote control



RC-E4 (option) **RCH-E3 (option)**

Wireless remote control



RCN-KIT3-E (option)

Specifications

Item	Model	FDTW28KXE6D	FDTW45KXE6D	FDTW56KXE6D	FDTW71KXE6D	FDTW90KXE6D	FDTW112KXE6D	FDTW140KXE6D
Nominal cooling capacity	kW	2.8	4.5	5.6	7.1	9.0	11.2	14.0
Nominal heating capacity	kW	3.2	5.0	6.3	8.0	10.0	12.5	16.0
Power source		1 Phase 220-240V, 50Hz						
Power consumption	Cooling	0.09-0.10			0.10-0.11	0.12-0.13	0.18-0.20	0.20-0.24
	Heating	0.09-0.10			0.10-0.11	0.12-0.13	0.18-0.20	0.20-0.24
Sound pressure level	dB(A)	Hi:39 Me:34 Lo:32			Hi:41 Me:36 Lo:35	Hi:41 Me:37 Lo:36	Hi:44 Me:41 Lo:39	Hi:45 Me:41 Lo:39
Exterior dimensions H x W x D	mm	Unit:287x817x620 Panel:8x1055x680			Unit:342x1054x620 Panel:8x1300x680	Unit:357x1524x620 Panel:8x1770x680		
Net weight	kg	Unit:18 Panel:7	Unit:19 Panel:7		Unit:26 Panel:9		Unit:38 Panel:11	
Air flow	CMM	Hi:14 Me:12 Lo:10			Hi:16 Me:13 Lo:11	Hi:19 Me:16 Lo:12	Hi:28 Me:25 Lo:23	Hi:32 Me:28 Lo:24
Outside air intake		Possible						
Panel		TW-PSA-25W-E			TW-PSA-35W-E		TW-PSA-45W-E	
Air filter, Q'ty		Pocket Plastic net x1 (Washable)				Pocket Plastic net x2 (Washable)		
Remote control(option)		wired:RC-E4, RCH-E3 wireless:RCN-KIT3-E						
Installation data		Liquid line:ø6.35(1/4") Gas line:ø9.52(3/8")		Liquid line:ø6.35(1/4") Gas line:ø12.7(1/2")		Liquid line:ø9.52(3/8") Gas line:ø15.88(5/8")		

1. The data are measured under the following conditions(ISO-T1). Cooling: Indoor temp. of 27°CDB, 19°CWB, and outdoor temp. of 35°CDB. Heating: Indoor temp. of 20°CDB, and outdoor temp. of 7°CDB, 6°CWB.
 2. Sound pressure level indicates the value in an anechoic chamber. During operation these values are somewhat higher due to ambient conditions.
 ※ Powerful-Hi can be selected. Sound pressure level: FDTW28/45/56 39dB(A), FDTW71/90 41dB(A), FDTW112 44dB(A), FDTW140 45dB(A). Air flow: FDTW28/45/56 14CMM, FDTW71 16CMM, FDTW90 19CMM, FDTW112 28CMM, FDTW140 32CMM.

Dimensions

All measurements in mm.

FDTW28KXE6D, 45KXE6D, 56KXE6D

FDTW71KXE6D, 90KXE6D

FDTW112KXE6D, 140KXE6D

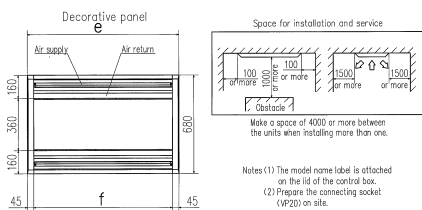
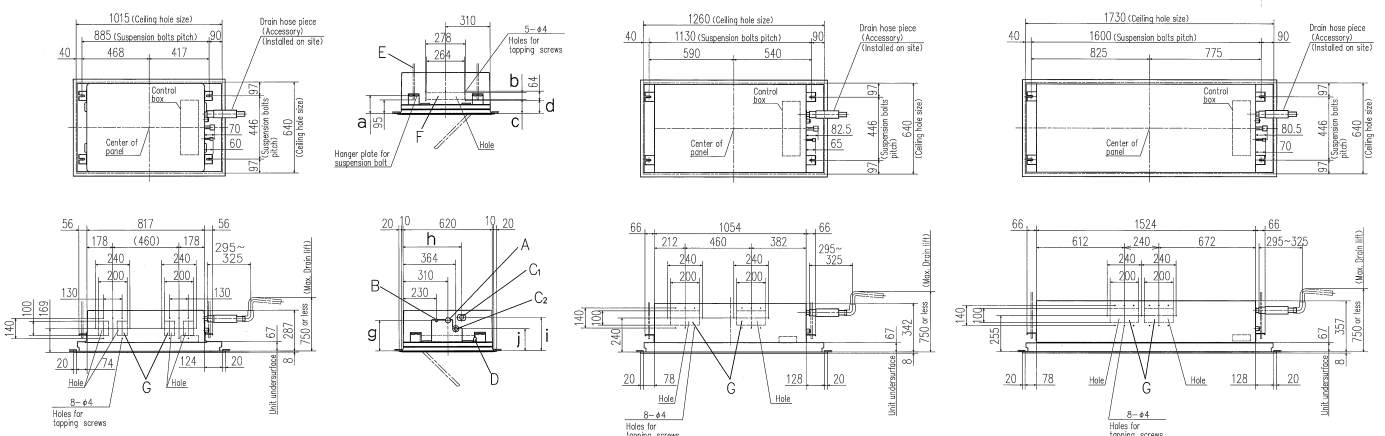

Symbol	Model	Content
	FDTW28KXE6D	FDTW56KXE6D, FDTW71KXE6D, 90KXE6D, 112KXE6D, 140KXE6D
A	Gas piping	ø9.52(3/8") (Flare) ø12.7(1/2") (Flare)
B	Liquid piping	ø6.35(1/4") (Flare) ø9.52(3/8") (Flare)
C1	Drain piping	VP20(1D, 2B, 0D, 2B) Note (2)
C2	Drain piping (Gravily drainage)	VP20
D	Hole for wiring	(M10)
E	Suspension bolts	(M10)
F	Outside air opening for ducting	(Knock out)
G	Air outlet opening for ducting	(Knock out)

Dimension Table

model	a	b	c	d	e	f	g	h	i	j
FDTW28,45,56KXE6D	127	47	98	91	1055	965	214	405	234	155
FDTW71,90KXE6D	127	50	95	88	1300	1210	226	410	284	155
FDTW112,140KXE6D	137	50	110	103	1770	1680	241	410	299	170

Ceiling Cassette -1way- FDTS

Model No.
FDTS45KXE6D
FDTS71KXE6D



Wired remote control



RC-E4 (option) **RCH-E3 (option)**

Wireless remote control



RCN-KIT3-E (option)

Specifications

Item	Model	FDTS45KXE6D	FDTS71KXE6D
Nominal cooling capacity	kW	4.5	7.1
Nominal heating capacity	kW	5.0	8.0
Power source		1 Phase 220-240V, 50Hz	
Power consumption	Cooling	0.10-0.12	0.13-0.16
	Heating	0.10-0.12	0.13-0.16
Sound pressure level**	dB(A)	Hi:43 Me:38 Lo:36	Hi:44 Me:38 Lo:36
Exterior dimensions H x W x D	mm	Unit:194x1040x650 Panel:10x1290x770	Unit:194x1300x650 Panel:10x1500x770
Net weight	kg	Unit:27 Panel:6	Unit:31 Panel:7
Air flow **	CMM	Hi:14 Me:12 Lo:10	Hi:18 Me:15 Lo:12
Outside air intake		Possible	
Panel		TS-PSA-29W-E	TS-PSA-39W-E
Air filter, Q'ty		Pocket plastic net x2 (Washable)	Pocket plastic net x3 (Washable)
Remote control(option)		wired:RC-E4, RCH-E3 wireless:RCN-KIT3-E	
Installation data		Liquid line:ø6.35(1/4") Gas line:ø12.7(1/2")	Liquid line:ø9.52(3/8") Gas line:ø15.88(5/8")
Refrigerant piping size	mm(in)		

1. The data are measured under the following conditions(ISO-T1). Cooling: Indoor temp. of 27°CDB, 19°CWB, and outdoor temp. of 35°CDB. Heating: Indoor temp. of 20°CDB, and outdoor temp. of 7°CDB, 6°CWB.
2. Sound pressure level indicates the value in an anechoic chamber. During operation these values are somewhat higher due to ambient conditions.

** Powerful-Hi can be selected. Sound pressure level: FDTS45 44dB(A), FDTS71 45 dB(A). Air flow: FDTS45 16CMM, FDTS71 20CMM.

Dimensions

All measurements in mm.

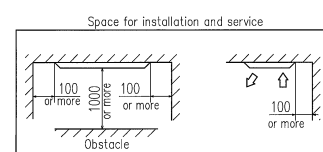
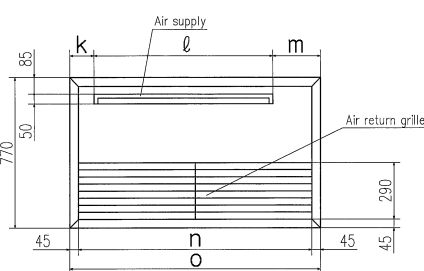
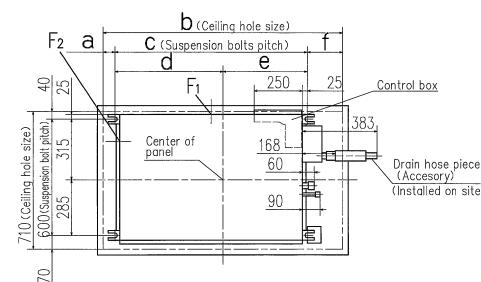

Make a space of 4000 or more between the units when installing more than one.

- Notes (1) The model name label is attached on the fan case inside the air return grille.
(2) Prepare the connecting socket (VP20) on site.

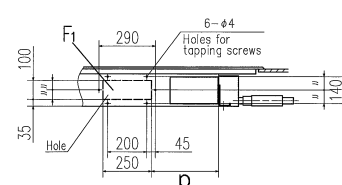
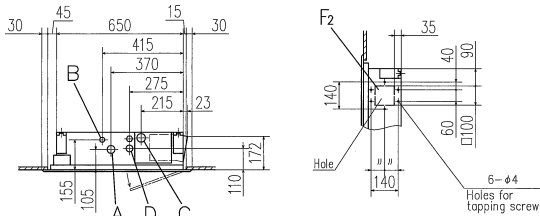
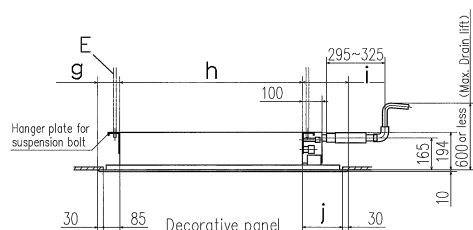

Symbol	Model	Content	
		FDTS45KXE6D	FDTS71KXE6D
A	Gas piping	ø12.7 (1/2") (Flare)	ø15.88 (5/8") (Flare)
B	Liquid piping	ø6.35 (1/4") (Flare)	ø9.52 (3/8") (Flare)
C	Drain piping	VP20(I.D.20, O.D.26) Note (2)	VP20(I.D.20, O.D.26) Note (2)
D	Hole for wiring	ø35	ø35
E	Suspension bolts	(M10)	(M10)
F1,2	Outside air opening for ducting	(Knock out)	(Knock out)

Dimension Table

Unit:mm

model	a	b	c	d	e	f	g	h	i	j	k	l	m	n	o	p
FDTS45KXE6D	60	1230	990	555	435	180	115	940	235	205	125	920	245	1200	1290	345
FDTS71KXE6D	45	1440	1250	675	575	145	100	1200	200	70	110	1180	210	1410	1500	475



Ceiling Cassette -1way Compact-FDTQ

Model No.
 FDTQ22KXE6D
 FDTQ28KXE6D
 FDTQ36KXE6D



Fits into standard
 600 x 600 ceiling

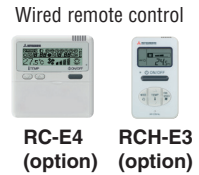

- Comfortable effective cooling for small rooms, with low fan speed air flow at just 5.4m³/min.



Optional wide panel shown for solid ceiling

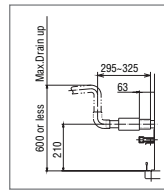

Condensate drain pump included as standard

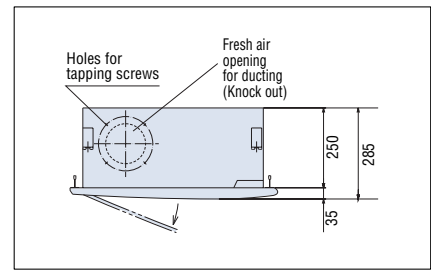

Ultra slim design at just 250mm above the ceiling

Specifications

Item	Model	FDTQ22KXE6D				FDTQ28KXE6D				FDTQ36KXE6D			
Panel Name		Direct blow panel		Duct panel		Direct blow panel		Duct panel		Direct blow panel		Duct panel	
Panel mode (Option)		TQ-PSA-15W-E	TQ-PSB-15W-E	QR-PNA-14W-ER	QR-PNB-14W-ER	TQ-PSA-15W-E	TQ-PSB-15W-E	QR-PNA-14W-ER	QR-PNB-14W-ER	TQ-PSA-15W-E	TQ-PSB-15W-E	QR-PNA-14W-ER	QR-PNB-14W-ER
Nominal cooling capacity	kW	2.2				2.8				3.6			
Nominal heating capacity	kW	2.5				3.2				4.0			
Power source		1 Phase 220-240V, 50Hz											
Power consumption	Cooling	0.05-0.07				0.05-0.07				0.05-0.07			
	Heating	0.05-0.07				0.05-0.07				0.05-0.07			
Sound pressure level ※	dB(A)	Hi:41 Me:38 Lo:33		Hi:41 Me:38 Lo:33		Hi:41 Me:38 Lo:33		Hi:41 Me:38 Lo:33		Hi:41 Me:38 Lo:33		Hi:41 Me:38 Lo:33	
Exterior dimensions	Unit	250x570x570											
	Panel	mm	35x625x650	35x780x650	35x625x650	35x780x650	35x625x650	35x780x650	35x625x650	35x780x650	35x625x650	35x780x650	35x625x650
Net weight	kg	Unit:23 Panel:2.5	Unit:23 Panel:3	Unit:23 Panel:2.5	Unit:23 Panel:3	Unit:23 Panel:2.5	Unit:23 Panel:3	Unit:23 Panel:2.5	Unit:23 Panel:3	Unit:23 Panel:2.5	Unit:23 Panel:3	Unit:23 Panel:2.5	Unit:23 Panel:3
Air flow ※	CMM	Hi:7 Me:6 Lo:5		Hi:7 Me:6 Lo:5		Hi:7 Me:6 Lo:5		Hi:7 Me:6 Lo:5		Hi:7 Me:6 Lo:5		Hi:7 Me:6 Lo:5	
Outside air intake		Possible											
Air filter, Q'ty		Pocket Plastic net x1 (Washable)											
Remote control(option)		wired:RC-E4, RCH-E3 wireless:RCN-KIT3-E											
Installation data		Liquid line:ø6.35(1/4") Gas line:ø9.52(3/8")											
Refrigerant piping size	mm(in)	Liquid line:ø6.35(1/4") Gas line:ø12.7(1/2")											

1. The data are measured under the following conditions(ISO-T1). Cooling: Indoor temp. of 27°CDB, 19°CWB, and outdoor temp. of 35°CDB. Heating: Indoor temp. of 20°CDB, and outdoor temp. of 7°CDB, 6°CWB.
 2. Sound pressure level indicates the value in an anechoic chamber. During operation these values are somewhat higher due to ambient conditions.

※ Powerful-Hi can be selected. Sound pressure level: FDTQ22/38/36 45dB(A). Air flow: FDTQ22/38/36 8CMM.

Dimensions

All measurements in mm.

Direct blow panel (TQ-PSA-15W-E)

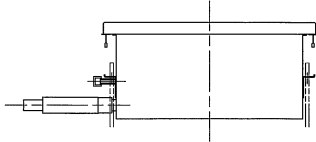

Direct blow panel (TQ-PSB-15W-E)

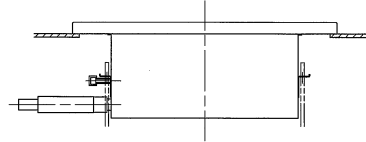

Symbol	Model	Content
		FDTQ22KXE6D, 28KXE6D
		FDTQ36KXE6D
A	Gas piping	ø9.52 (3/8") (Flare)
B	Liquid piping	ø6.35 (1/4") (Flare)
C	Drain piping	VP20(I.D.20, O.D.26) Note (2)
D	Hole for wiring	ø30
E	Suspension bolts	(M10)
F1,2	Outside air opening for ducting	(Knock out)

Duct panel (QR-PNA-14W-ER)

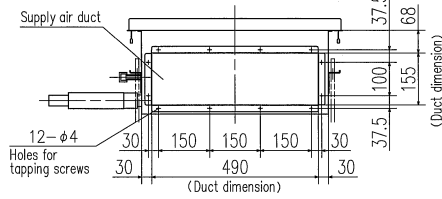

Duct panel (QR-PNB-14W-ER)

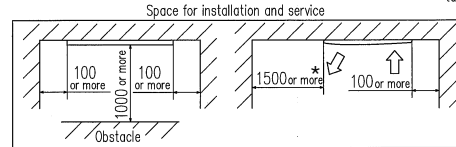
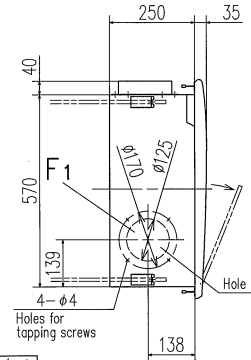
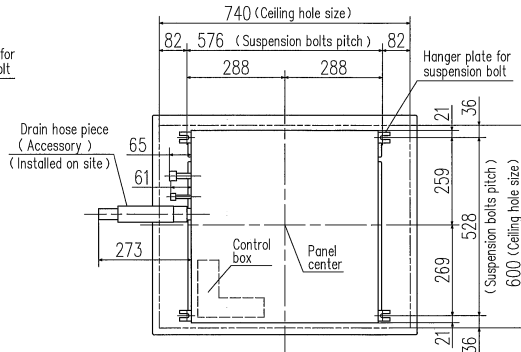
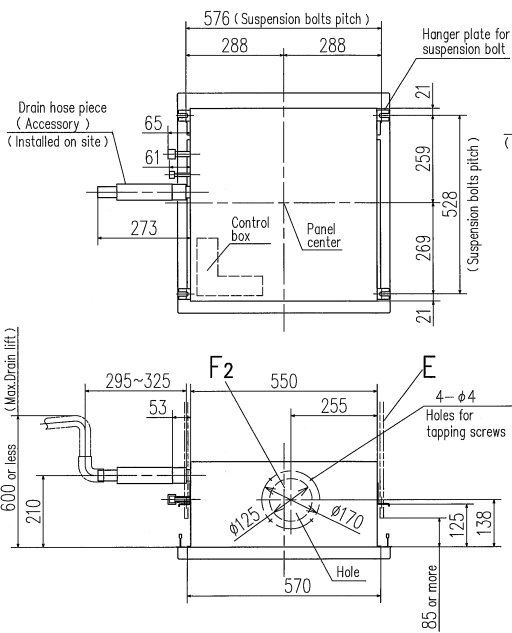
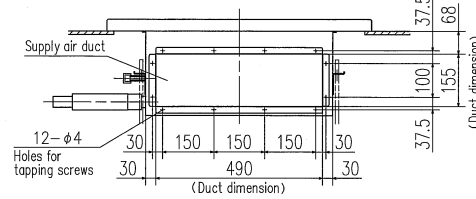

Make a space of 3000 or more between the units when installing more than one.

Notes

- (1) The model name label is attached on the fan case inside the air return grille.
- (2) Prepare the connecting socket (VP20) on site.
- (3) This unit is designed for 2X2 grid ceiling.
* In case of Direct blow panel

Decorative panel

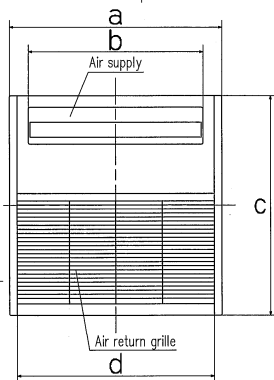

Decorative panel

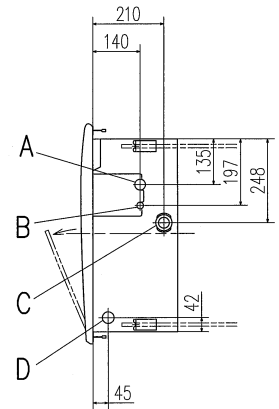
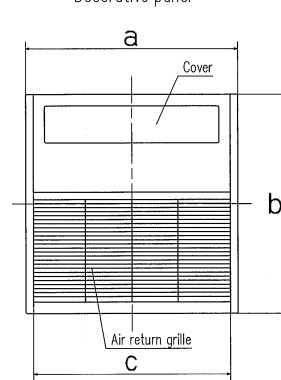

Dimension Table

Unit:mm

model	a	b	c	d
TQ-PSA-15W-E	625	514	650	580
TQ-PSB-15W-E	780	514	650	580

Dimension Table

Unit:mm

model	a	b	c
QR-PNA-14W-ER	625	650	580
QR-PNB-14W-ER	780	650	580



Duct Connected -High Static Pressure- FDU

Model No.
 FDU71KXE6D
 FDU90KXE6D
 FDU112KXE6D
 FDU140KXE6D



Wired remote control



RC-E4 (option) **RCH-E3 (option)**

Wireless remote control



RCN-KIT3-E (option)

Dimensions

All measurements in mm.

FDU71KXE6D

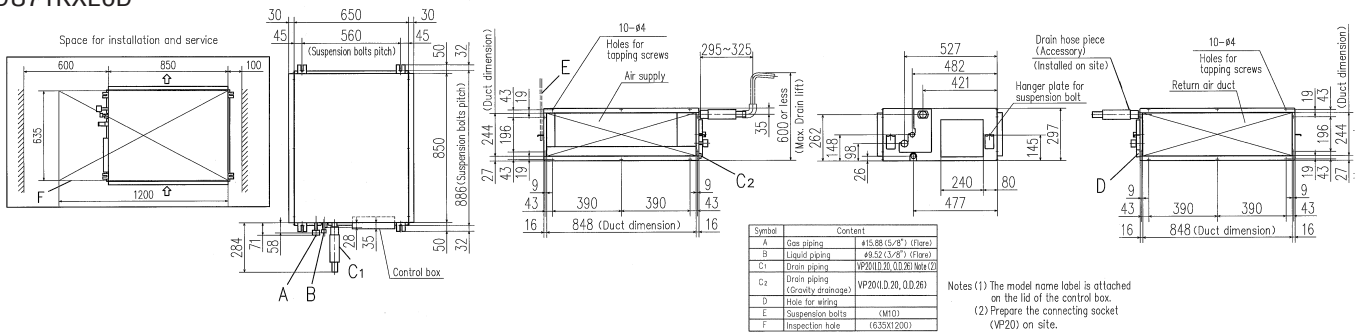

FDU90KXE6D, 112KXE6D, 140KXE6D

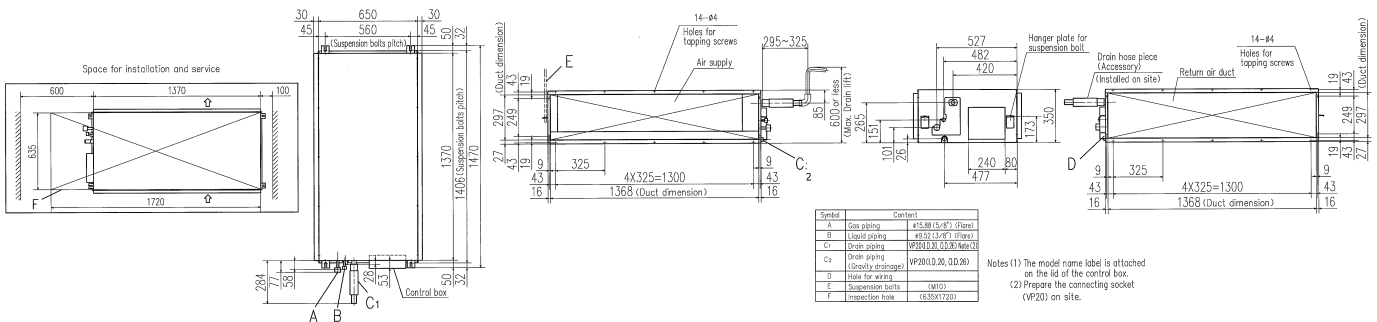

Specifications

Item	Model	FDU71KXE6D	FDU90KXE6D	FDU112KXE6D	FDU140KXE6D
Nominal cooling capacity	kW	7.1	9.0	11.2	14.0
Nominal heating capacity	kW	8.0	10.0	12.5	16.0
Power source		1 Phase 220-240V, 50Hz			
Power consumption	Cooling kW	0.29-0.32	0.35-0.39	0.39-0.45	
	Heating kW	0.27-0.30	0.34-0.38	0.34-0.39	
Sound pressure level	dB(A)	Hi:41 Lo:37	Hi:42 Lo:37	Hi:42 Lo:38	Hi:43 Lo:39
Exterior dimensions	H x W x D	297x850x650		350x1370x650	
Net weight	kg	40		63	
Air flow (Standard)	CMM	Hi:20 Lo:17	Hi:34 Lo:27		Hi:42 Lo:33.5
External Static pressure	Pa	Standard:60, Max:130			
Outside air intake		Possible(on Return duct)			
Air filter, Q'ty		Procure locally			
Remote control(option)		wired:RC-E4, RCH-E3 wireless:RCN-KIT3-E			
Installation data	Refrigerant piping size	Liquid line:φ9.52(3/8") Gas line:φ15.88(5/8")			

1. The data are measured under the following conditions(ISO-T1). Cooling: Indoor temp. of 27°CDB, 19°CWB, and outdoor temp. of 35°CDB. Heating: Indoor temp. of 20°CDB, and outdoor temp. of 7°CDB, 6°CWB. External static pressure of indoor unit is 60Pa.
 2. Sound pressure level indicates the value in an anechoic chamber. During operation these values are somewhat higher due to ambient conditions.
 3. External static pressure can be changed from standard external static pressure (factory setting) to maximum external static pressure (high static pressure setting) by remote control.
 4. Values of sound pressure level become increased 5dB(A), when external static pressure is 130Pa.

Duct Connected -High Static Pressure- FDU

Model No.
FDU224KXE6D
FDU280KXE6D



Wired remote control



RC-E4
(option)



RCH-E3
(option)

Wireless remote control



RCN-KIT3-E
(option)



Fan control kit
(100~200Pa)
U-FCRA(option)

Dimensions

All measurements in mm.

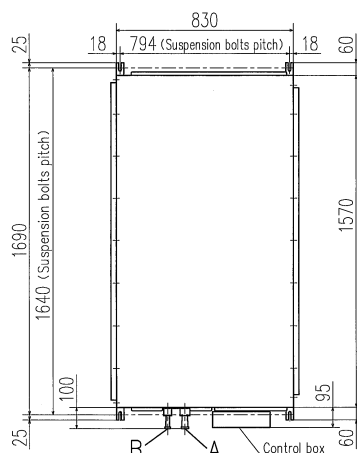

Symbol	Model	Content
	FDU224KXE6D	FDU280KXE6D
A	Gas piping	φ25.4 (1") (Brazing)
B	Liquid piping	φ9.52 (3/8") (Brazing) φ12.7 (1/2") (Brazing)
C	Drain piping	VP20 (I.D.20, O.D.26)
D	Hole for wiring	φ25
E	Suspension bolts	(M10)
F	Inspection hole	(600X600)
G	Inspection hole	(900X1730)

Note (1) The model name label is attached on the side plate of the control box.

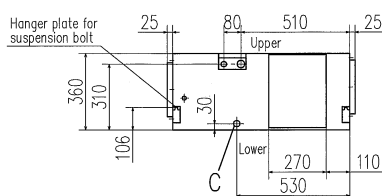
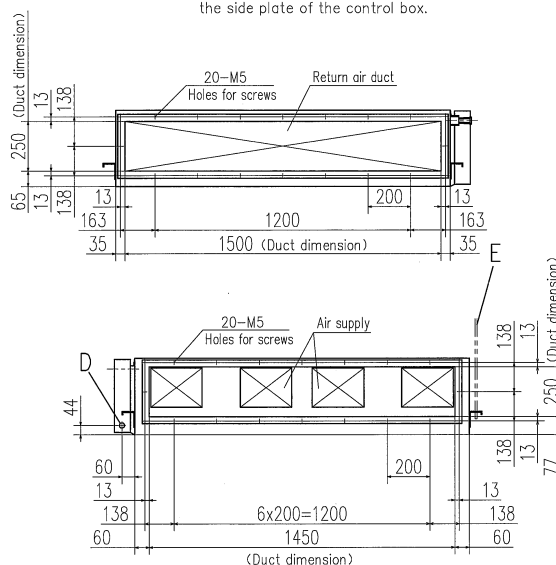

Specifications

Item	Model	FDU224KXE6D	FDU280KXE6D
Nominal cooling capacity	kW	22.4	28.0
Nominal heating capacity	kW	25.0	31.5
Power source		1 Phase 220-240V, 50Hz	
Power consumption	Cooling	0.94-1.03	0.96-1.05
	Heating	0.86-0.90	0.88-0.96
Sound pressure level	dB(A)	Hi:51	Hi:52
Exterior dimensions H x W x D	mm	360x1570x830	
Net weight	kg	92	
Air flow (Standard)	CMM	Hi:51	Hi:68
External Static pressure	Pa	200	
Outside air intake		Possible(on Return duct)	
Air filter, Q'ty		Procure locally	
Remote control(option)		wired:RC-E4, RCH-E3 wireless:RCN-KIT3-E	
Installation data	mm(m)	Liquid line:φ9.52(3/8") Gas line:φ19.05(3/4")	Liquid line:φ9.52(3/8") Gas line:φ22.22(7/8")

- The data are measured under the following conditions(ISO-T1). Cooling: Indoor temp. of 27°CDB, 19°CWB, and outdoor temp. of 35°CDB. Heating: Indoor temp. of 20°CDB, and outdoor temp. of 7°CDB, 6°CWB. External static pressure of indoor unit is 100Pa.
- Sound pressure level indicates the value in an anechoic chamber. During operation these values are somewhat higher due to ambient conditions.
- Values of sound pressure level become increased 5dB(A), when external static pressure is 200Pa (factory setting).
- Values of air flow volume are those at external static pressure 200Pa (factory setting).



Duct Connected -Low/Middle Static Pressure- FDUM

- Model No.**
 FDUM22KXE6D
 FDUM28KXE6D
 FDUM36KXE6D
 FDUM45KXE6D
 FDUM56KXE6D
 FDUM71KXE6D
 FDUM90KXE6D
 FDUM112KXE6D
 FDUM140KXE6D

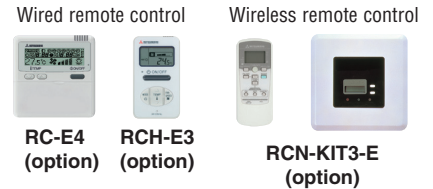

Filter kit
UM-FL1E : for 22-56
UM-FL2E : for 71, 90
UM-FL3E : for 112, 140 (option)



* Filter pressure loss:5pa

Specifications

Item	Model	FDUM22KXE6D	FDUM28KXE6D	FDUM36KXE6D	FDUM45KXE6D	FDUM56KXE6D	FDUM71KXE6D	FDUM90KXE6D	FDUM112KXE6D	FDUM140KXE6D	
Nominal cooling capacity	kW	2.2	2.8	3.6	4.5	5.6	7.1	9.0	11.2	14.0	
Nominal heating capacity	kW	2.5	3.2	4.0	5.0	6.3	8.0	10.0	12.5	16.0	
Power source		1 Phase 220-240V, 50Hz									
Power consumption	Cooling	0.10-0.12		0.13-0.15		0.16-0.18		0.17-0.19		0.18-0.21	
	Heating	0.10-0.12		0.13-0.15		0.16-0.18		0.17-0.19		0.18-0.21	
Sound pressure level**	dB(A)	Hi:33 Me:31 Lo:28	Hi:34 Me:31 Lo:28		Hi:35 Me:32 Lo:29		Hi:35 Me:32 Lo:29	Hi:36 Me:33 Lo:30	Hi:37 Me:35 Lo:32	Hi:38 Me:36 Lo:33	
Exterior dimensions H x W x D	mm	299 x 750 x 635					299 x 950 x 635			350 x 1370 x 635	
Net weight	kg	33	34				40			59	
Air flow **	CMM	Hi:10 Me:9 Lo:8	Hi:12 Me:11 Lo:10		Hi:13 Me:12 Lo:11		Hi:16 Me:15 Lo:14	Hi:20 Me:18 Lo:15	Hi:28 Me:25 Lo:22	Hi:28 Me:25 Lo:22	
External Static pressure	Pa	85 (at 10CMM)	85(at 12CMM)		85(at 14CMM)		85 (at 18CMM)	85 (at 20CMM)	90 (at 28CMM)	85 (at 34CMM)	
Outside air intake		Possible									
Air filter, Q'ty		Procure locally									
Remote control(option)		wired:RC-E4, RCH-E3 wireless:RCN-KIT3-E									
Installation data	mm(in)	Liquid line:ø6.35(1/4") Gas line:ø9.52(3/8")			Liquid line:ø6.35(1/4") Gas line:ø12.7(1/2")			Liquid line:ø9.52(3/8") Gas line:ø15.88(5/8")			

1. The data are measured under the following conditions(ISO-T1). Cooling: Indoor temp. of 27°CDB, 19°CWB, and outdoor temp. of 35°CDB. Heating: Indoor temp. of 20°CDB, and outdoor temp. of 7°CDB, 6°CWB. External static pressure of indoor unit is 60Pa.
 2. Sound pressure level indicates the value in an anechoic chamber. During operation these values are somewhat higher due to ambient conditions.
 * Powerful-Hi can be selected. Sound pressure level: FDUM22/28/36 35dB(A), FDUM45/56 36dB(A), FDUM71/90 38dB(A), FDUM112/140 41dB(A). Air flow: FDUM22 12CMM, FDUM28/36/45/56 14CMM, FDUM71 18CMM, FDUM90 23 CMM, FDUM112/140 34CMM.

Dimensions

All measurements in mm.

FDUM22KXE6D

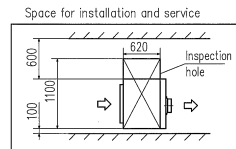
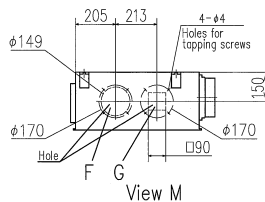
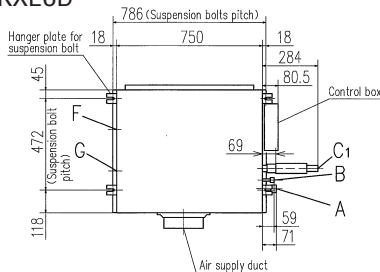

Notes (1) The model name label is attached on the lid of the control box.
 (2) Prepare the connecting socket (VP20) on site.

Symbol	Content
A	Gas piping ø9.52 (3/8") (Flare)
B	Liquid piping ø6.35 (1/4") (Flare)
C1	Drain piping VP20(I.D.20, O.D.26) Note (2)
C2	Drain piping (Gravity drainage) VP20(I.D.20, O.D.26)
D	Hole for wiring (M10)
E	Suspension bolts (M10)
F	Outside air opening for ducting (ø150) (Knock out)
G	Air outlet opening for ducting (ø125) (Knock out)

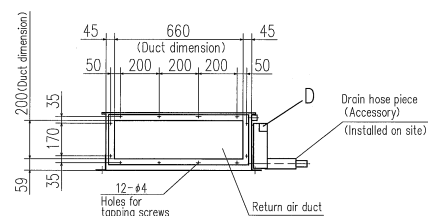
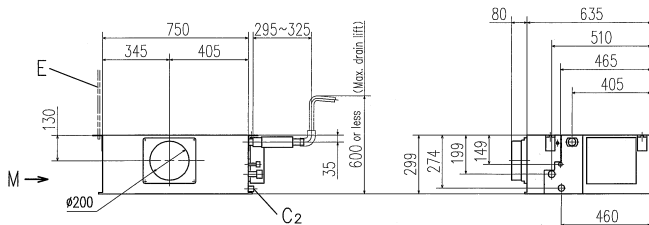

FDUM28KXE6D, 36KXE6D, 45KXE6D, 56KXE6D

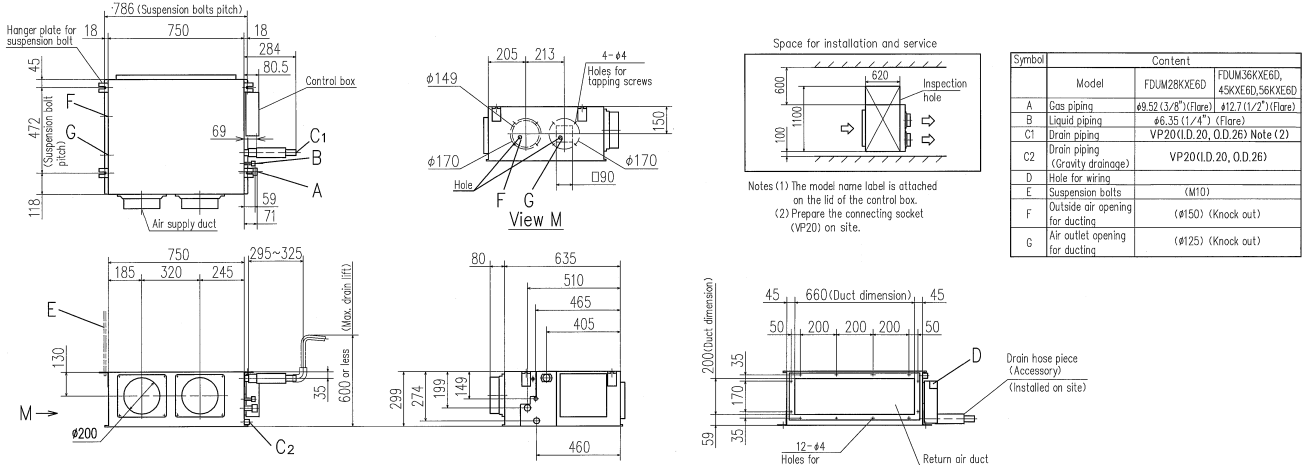

FDUM71KXE6D, 90KXE6D

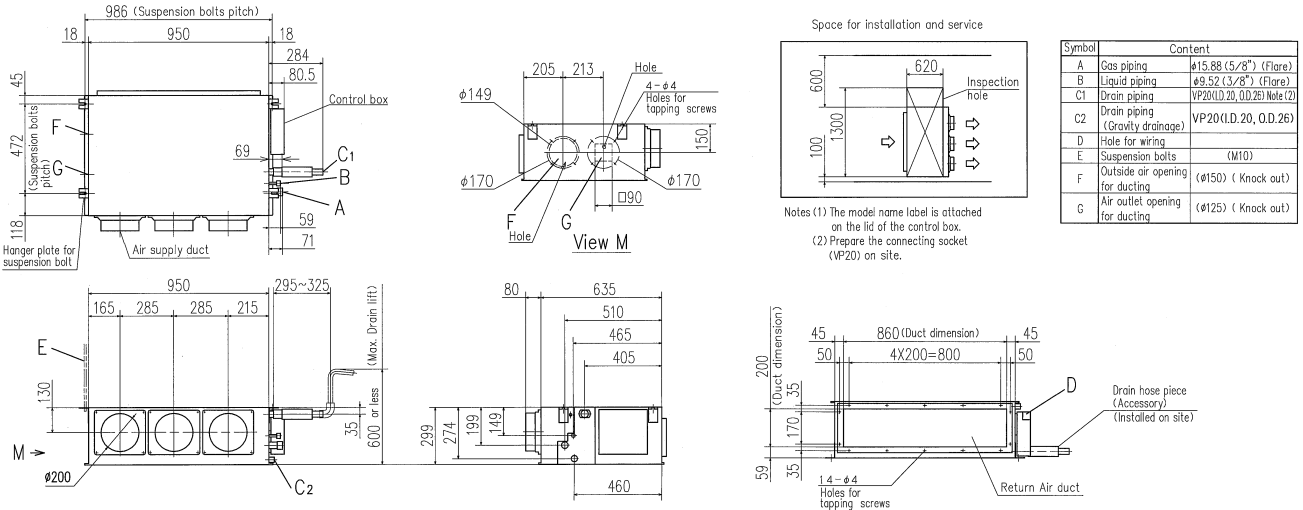

FDUM112KXE6D, 140KXE6D

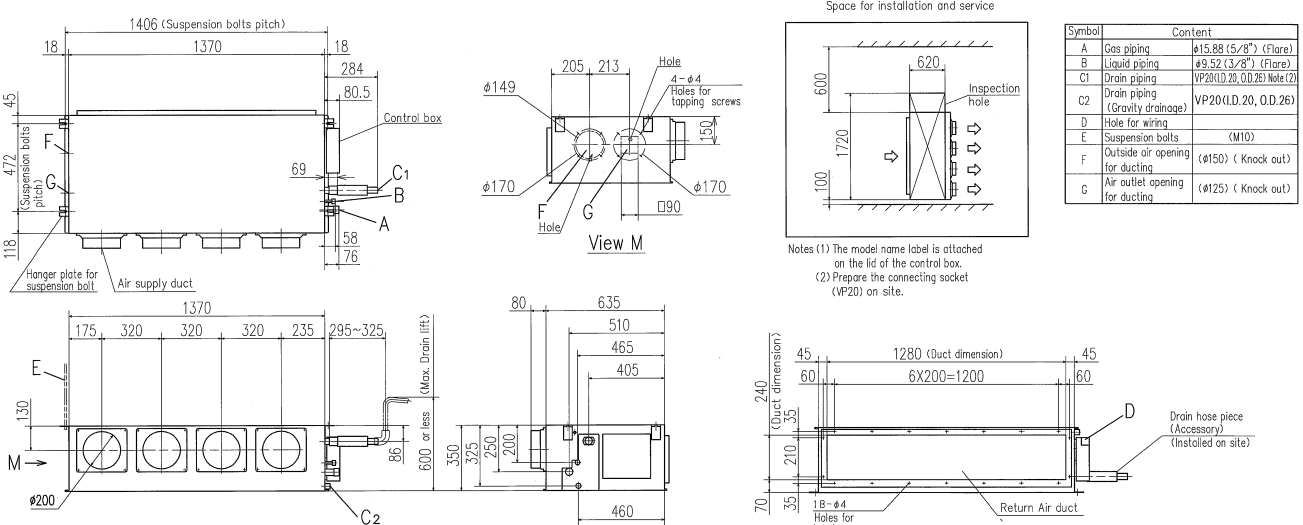



Duct Connected (thin) -Low Static Pressure- FDUT

Model No.
 FDUT22KXE6D
 FDUT28KXE6D
 FDUT36KXE6D
 FDUT45KXE6D
 FDUT56KXE6D



Wired remote control



RC-E4 (option)



RCH-E3 (option)

Wireless remote control



RCN-KIT3-E (option)

Suction guard set
 UT-FL1E(22,28,36)
 UT-FL2E(45,56)
 (option)



*Filter pressure loss:5pa

Duct air supply kit
 UT-DAS1E(22,28,36)
 UT-DAS2E(45,56)
 (option)

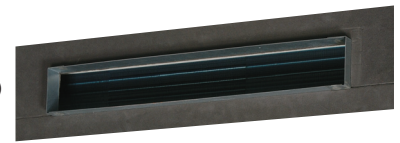

Using these kits, external static pressure of 35Pa for FDUT22/28/36KXE6D and 50Pa for FDUT45/56KXE6D can be attained.

600mm Drain Pump as standard equipment

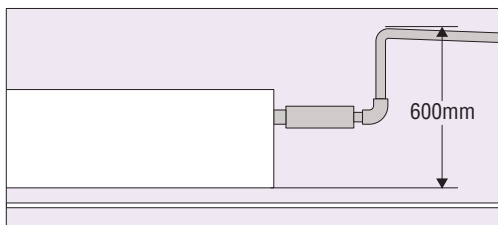

Drain can be discharged upwards by 600mm from the unit bottom. It allows a piping layout with a high degree of freedom depending on the installation location.

Quiet operation (in both of cooling and heating)

Thanks to optimum balance of unit design and air outlet direction, the sound level has been minimized. The level of FDUT22KXE6D is 24 dB(A) in case of low mode operation.

in case of FDUT22KXE6D

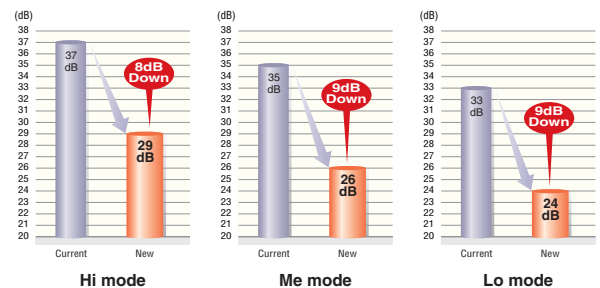

Specifications

Item	Model	FDUT22KXE6D	FDUT28KXE6D	FDUT36KXE6D	FDUT45KXE6D	FDUT56KXE6D
Nominal cooling capacity	kW	2.2	2.8	3.6	4.5	5.6
Nominal heating capacity	kW	2.5	3.2	4.0	5.0	6.0
Power source		1 Phase 220-240V, 50Hz				
Power consumption	Cooling	0.05-0.06		0.06-0.07	0.08-0.09	0.11-0.13
	Heating	0.05-0.06		0.06-0.07	0.08-0.09	0.11-0.13
Sound pressure level	dB(A)	Hi:29 Me:26 Lo:24		Hi:33 Me:31 Lo:28	Hi:35 Me:32 Lo:28	Hi:36 Me:34 Lo:31
Exterior dimensions H x W x D	mm	220x750x520			220x950x520	
Net weight	kg	26			28	
Air flow (Standard)	CMM	Hi:7.5 Me:6 Lo:5		Hi:8.5 Me:7 Lo:6	Hi:12 Me:10 Lo:8	Hi:12.5 Me:10 Lo:8.5
External static pressure	Pa	10			10	
Outside air intake		Not possible				
Suction guard(Air filter)		Procure locally				
Remote control(option)		wired:RC-E4 RCH-E3 wireless:RCN-KIT3-E				
Installation data Refrigerant piping size	mm(in)	Liquid line:ø6.35(1/4") Gas line:ø9.52(3/8")		Liquid line:ø6.35(1/4") Gas line:ø12.7(1/2")		

- The data are measured under the following conditions(ISO-T1). Cooling: Indoor temp. of 27°CDB, 19°CWB, and outdoor temp. of 35°CDB. Heating: Indoor temp. of 20°CDB, and outdoor temp. of 7°CDB, 6°CWB. External static pressure of indoor unit is 10Pa.
- The data of nominal cooling and heating capacity and sound pressure level are measured with 10Pa of external static pressure.
- The sound level indicates the value of rear-intake type with duct in anechoic chamber. During operation these values are somewhat higher due to ambient conditions.
- In case of using the duct air supply kit, the maximum external static pressure of FDUT22/28/36KXE6D is 35Pa and that of FDUT45/56KXE6D is 50Pa.
- Maximum external static pressure should be 35Pa when using duct flange plate kit "UT-DAS1E" and 50Pa when using "UT-DAS2E".

Dimensions

All measurements in mm.

FDUT22KXE6D, 28KXE6D, 36KXE6D

FDUT45KXE6D, 56KXE6D

common to all models

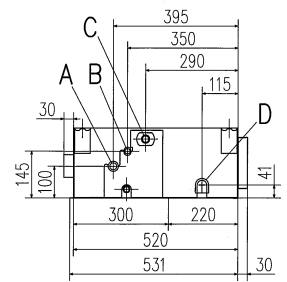
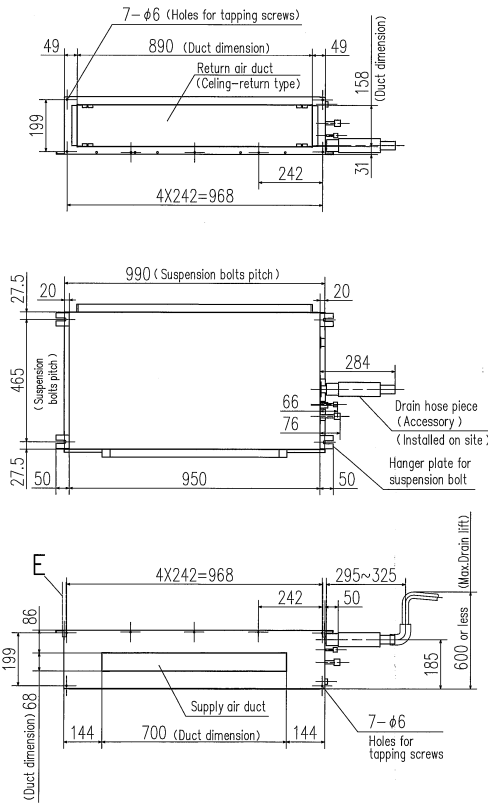
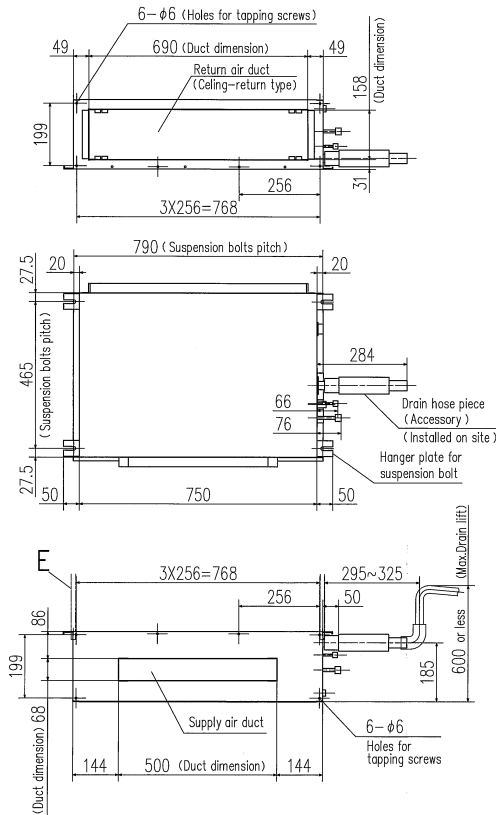

Symbol	Content		
	Model	22,28	36
A	Gas piping	φ9.52 (3/8") (Flare)	φ12.7 (1/2") (Flare)
B	Liquid piping	φ6.35 (1/4") (Flare)	
C	Drain piping	VP25 Note (2)	
D	Hole for wiring	φ35	
E	Suspension bolts	(M10)	

Symbol	Content		
	Model	45,56	
A	Gas piping	φ12.7 (1/2") (Flare)	
B	Liquid piping	φ6.35 (1/4") (Flare)	
C	Drain piping	VP25 Note (2)	
D	Hole for wiring	φ35	
E	Suspension bolts	(M10)	

Notes
 (1) The model name label is attached on the side plate.
 (2) Prepare the connecting socket (VP25) on site.

Space for installation and service

Recommended way to install the unit

Rear-intake type with duct (Standard installation)

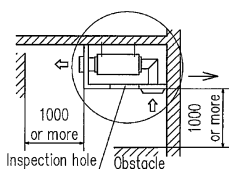

Rear-intake Ceiling-return type

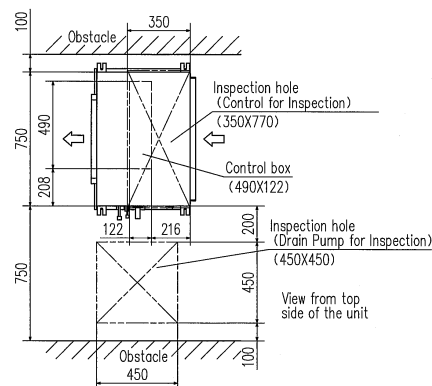
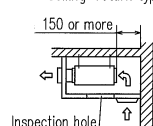

(in case of FDUT22/28/36KXE6D)

The following way of installation is available. Refer to our technical manual for detail.

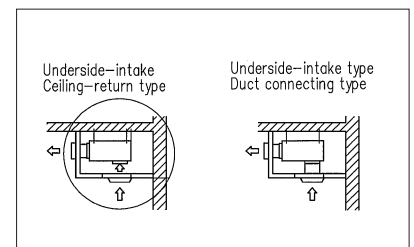



Duct Connected (Compact & Flexible) FDUH

Model No.

- FDUH22KXE6D
- FDUH28KXE6D
- FDUH36KXE6D



Filter kit
UH-FL1E



*Filter pressure loss:5pa

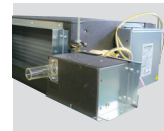

Drain up kit
(600mm)

UH-DU-E(option)

Wired remote control



RC-E4 (option) **RCH-E3 (option)**

Wireless remote control



RCN-KIT3-E (option)

Compact and thin size, light weight

Our leading high technology has realized the best solution for air conditioning in hotels with compact and thin size units and high energy efficiency. In addition, weight is only 20kg.

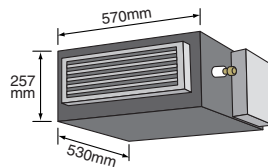

Quiet operation

The lowest sound level in the industry can ensure comfortable stay and rest in hotels.

Installation Flexibility

Control box and drain piping can be installed on both side of the unit and air intake to the unit is available from bottom or back side. Our highest technology can satisfy diverse installation requirements.

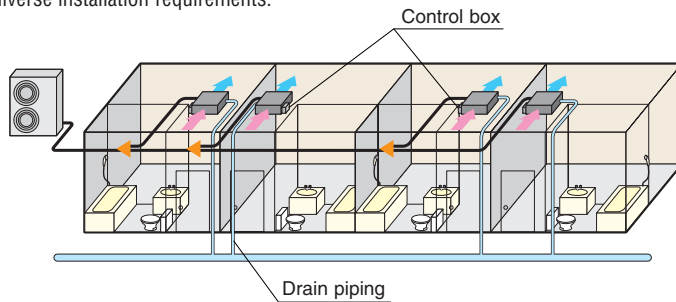

Wired remote control



RCH-E3 (option)

Simple remote control

Considering specialized usage in hotel rooms, control buttons are limited only to minimum required functions such as ON/OFF, mode, temperature setting and fan speed. It is really simple and easy to use.

Specifications

Item	Model	FDUH22KXE6D	FDUH28KXE6D	FDUH36KXE6D
Nominal cooling capacity	kW	2.2	2.8	3.6
Nominal heating capacity	kW	2.5	3.2	4.0
Power source		1 Phase 220-240V, 50Hz		
Power consumption	Cooling	0.05-0.07		
	Heating	0.05-0.07		
Sound pressure level**	dB(A)	HI: 33 Me: 30 Lo: 27		
Exterior dimensions HxWxD	mm	257x570x530		
Net weight	kg	22		
Air flow**	CMM	HI: 7 Me: 6.5 Lo: 6		
External static pressure	Pa	30		
Outside air intake		Not possible		
Air filter, Q'ty		Procure locally		
Remote control(option)		wired:RC-E4,RCH-E3 wireless:RCN-KIT3-E		
Installation data	mm(in)	Liquid line:ø6.35(1/4")		Liquid line:ø6.35(1/4")
	Refrigerant piping size	Gas line:ø9.52(3/8")		Gas line:ø12.7(1/2")

1. The data are measured under the following conditions(ISO-T1). Cooling: Indoor temp. of 27°CDB, 19°CWB, and outdoor temp. of 35°CDB. Heating: Indoor temp. of 20°CDB, and outdoor temp. of 7°CDB, 6°CWB.
2. Sound pressure level indicates the value in an anechoic chamber. During operation these values are somewhat higher due to ambient conditions.

** Powerful-Hi can be selected. Sound pressure level: FDUH22/28/36 39dB(A). Air flow: FDUH22/28/36 8.5CMM.

Dimensions

All measurements in mm.

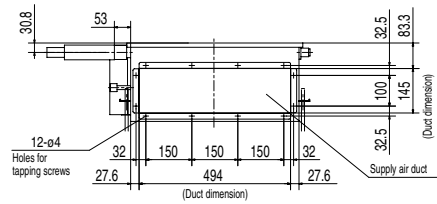

Symbol	Content		
	Model	FDUH22KXE6D, 28KXE6D	FDUH36KXE6D
A	Gas piping	φ9.52 (3/8") (Flare)	φ12.7 (1/2") (Flare)
B	Liquid piping	φ6.35 (1/4") (Flare)	
C, C ₂	Drain piping	VP20 (D.20, O.D.26) Note (2)	
D	Hole for wiring	φ30	
E	Suspension bolts	(M10)	
F	Inspection hole	(635X890) Note (3)	

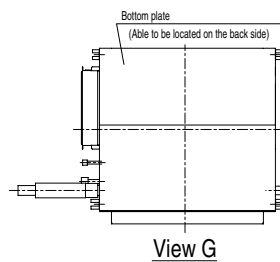
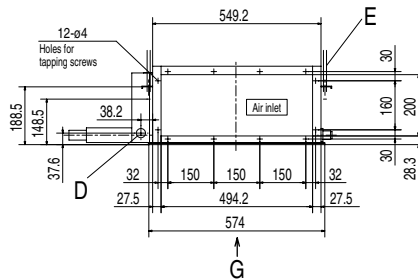
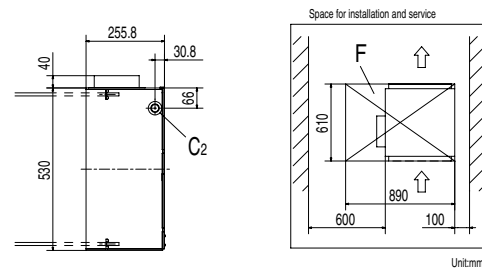
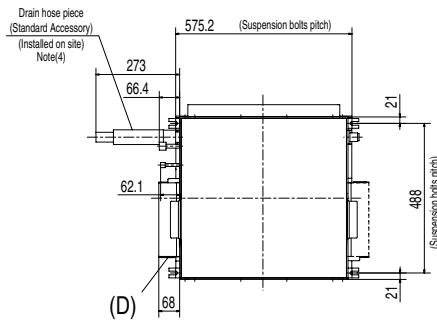
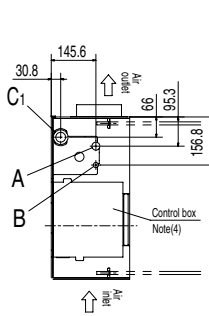

In case of Bottom air intake

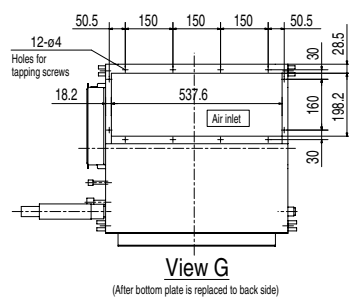

Notes

- (1) The model name label is attached on the fan case inside the air return grille.
- (2) Prepare the connecting socket (VP20) on site. (As for drain piping, it is possible to choose C₁ or C₂)
- (3) When control box is located on the reverse side, installation space should be modified to new location.
- (4) Control box and Drain hose piece are able to be relocated on the reverse side.

Simple remote control

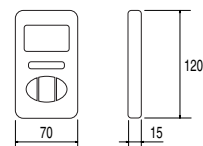



Wall Mounted FDK

Model No.

- FDK22KXE6D
- FDK28KXE6D
- FDK36KXE6D
- FDK45KXE6D
- FDK56KXE6D
- FDK71KXE6D



Wired remote control

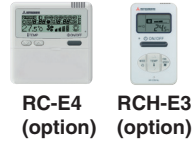

Wireless remote control



RCN-K-E : FDK22-56
RCN-K71-E : FDK71 (option)

Innovative Design

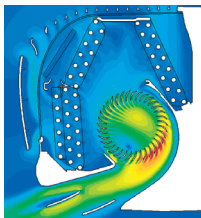

Fast ← → Slow
Colors in the figure show the air speed.

New FDK models adopt the air flow design that's proven to minimise resistance in a CFD analysis to achieve uniform air conditioning to the furthest corners of the room.

Installation Workability

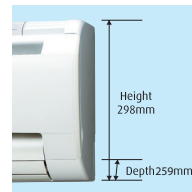

The new slimmer design allows easy & neat installation even in tight spaces.

Flap control system

Selection of flap position is possible. A flap can be set at different angles.

*RCH-E3 is not applicable to the Flap control system.

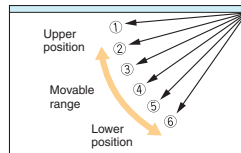

Improved Maintainability

Also included is a new easy clean mechanism where the front panel is opened/closed simply from the bottom to easily access the detachable filters.

Specifications

Item	Model	FDK22KXE6D	FDK28KXE6D	FDK36KXE6D	FDK45KXE6D	FDK56KXE6D	FDK71KXE6D	
Nominal cooling capacity	kW	2.2	2.8	3.6	4.5	5.6	7.1	
Nominal heating capacity	kW	2.5	3.2	4.0	5.0	6.3	8.0	
Power source		1 Phase 220-240V, 50Hz						
Power consumption	Cooling	0.05			0.05		0.09	
	Heating	0.04			0.05		0.09	
Sound pressure level **	Cooling	Hi:35 Me:33 Lo:31		Hi:41 Me:35 Lo:31	Hi:42 Me:37 Lo:33	Hi:46 Me:42 Lo:37	Hi:47 Me:43 Lo:39	
	Heating	Hi:35 Me:33 Lo:31		Hi:39 Me:35 Lo:31	Hi:42 Me:37 Lo:33	Hi:46 Me:42 Lo:37	Hi:47 Me:43 Lo:39	
Exterior dimensions H x W x D	mm	298 x 840 x 259					318 x 1098 x 248	
Net weight	kg	12			12.5	13	15.5	
Air flow **	CMM	Hi:8 Me:7 Lo:6		Hi:10 Me:9 Lo:7	Hi:11 Me:9 Lo:7	Hi:14 Me:12 Lo:10	Hi:21 Me:18 Lo:15	
Outside air intake		Not possible						
Air filter, Q'ty		Polypropylene net x2 (Washable)						
Remote control(option)		wired:RC-E4, RCH-E3 wireless:RCN-K-E (for FDK22-56), RCN-K71-E (for FDK71)						
Installation data		Liquid line:ø6.35(1/4") Gas line:ø9.52(3/8")			Liquid line:ø6.35(1/4") Gas line:ø12.7(1/2")		Liquid line:ø9.52(3/8") Gas line:ø15.88(5/8")	
Refrigerant piping size	mm(in)							

1. The data are measured under the following conditions(ISO-T1). Cooling: Indoor temp. of 27°CDB, 19°CWB, and outdoor temp. of 35°CDB. Heating: Indoor temp. of 20°CDB, and outdoor temp. of 7°CDB, 6°CWB.

2. Sound pressure level indicates the value in an anechoic chamber. During operation these values are somewhat higher due to ambient conditions.

** Powerful-Hi can be selected. Sound pressure level: FDK22/28 38dB(A), FDK36/45 48dB(A)(Cooling)&42dB(A)(Heating), FDK56 48dB(A)(Cooling)&46dB(A)(Heating), FDK71 47dB(A). Air flow: FDK22/28 11CMM, FDK36/45 15CMM, FDK56 16CMM, FDK71 24CMM.

Dimensions

All measurements in mm.

FDK22KXE6D, 28KXE6D, 36KXE6D, 45KXE6D, 56KXE6D

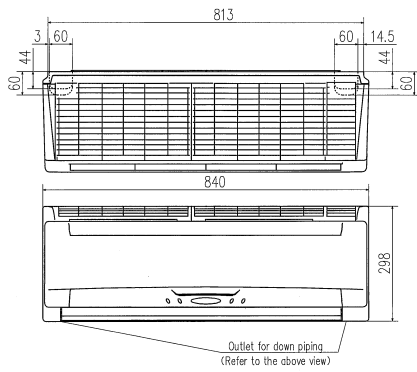

Note (1) The model name label is attached on the underside of the panel.

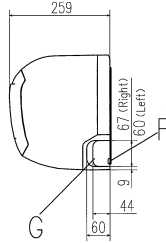

Symbol	Model	Content
	FDK22KXE6D, 28KXE6D FDK36KXE6D, 45KXE6D, 56KXE6D	
A	Gas piping	ø9.52 (3/8") (Flare) ø12.7 (1/2") (Flare)
B	Liquid piping	ø6.35 (1/4") (Flare)
C	Hole on wall for right rear piping	(ø65)
D	Hole on wall for left rear piping	(ø65)
E	Drain piping	VP16(1D.16)
F	Outlet for wiring	
G	Outlet for piping (on both side)	

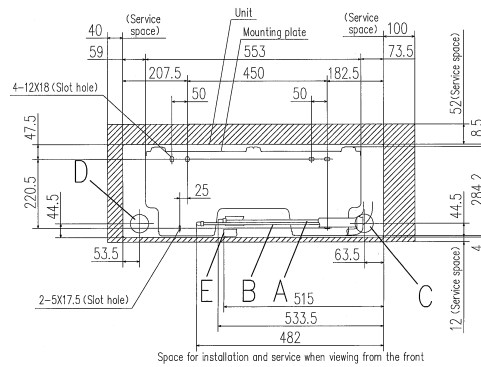

Space for installation and service when viewing from the front

FDK71KXE6D

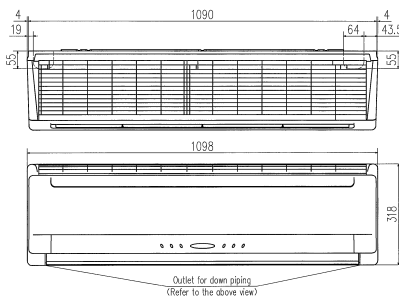

Note (1) The model name label is attached on the underside of the panel.

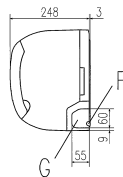

Symbol	Model	Content
	FDK71KXE6D	
A	Gas piping	ø15.88 (5/8") (Flare)
B	Liquid piping	ø9.52 (3/8") (Flare)
C	Hole on wall for right rear piping	(ø65)
D	Hole on wall for left rear piping	(ø65)
E	Drain piping	VP16(1D.16)
F	Outlet for wiring	
G	Outlet for piping (on both side)	

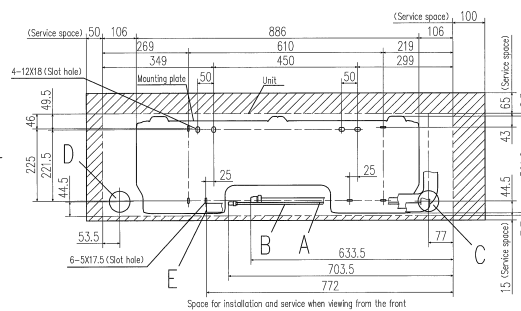

Space for installation and service when viewing from the front



Ceiling Suspended FDE

- Model No.**
 FDE36KXE6D
 FDE45KXE6D
 FDE56KXE6D
 FDE71KXE6D
 FDE112KXE6D
 FDE140KXE6D



- Small
- Light-weight
- Quiet
- Sleek, intelligent design

Wired remote control

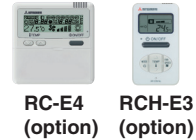

Wireless remote control



Flap control system

Selection of flap position is possible. A flap can be set at different angles.

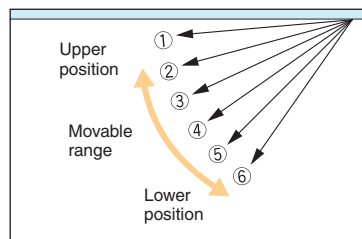

*RCH-E3 is not applicable to the Flap control system.

New Slim Design

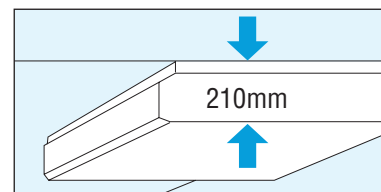

Slim and sleek design starting at just 28kgs in weight means quick, easy & neat installation.

Installation Workability

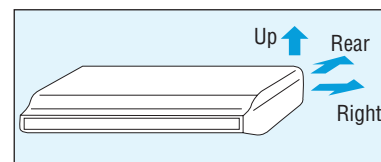

Refrigerant piping can be routed in three directions (rear, up, right) & drain piping in left or right directions, allowing free layout to meet installation conditions.

Specifications

Item	Model	FDE36KXE6D	FDE45KXE6D	FDE56KXE6D	FDE71KXE6D	FDE112KXE6D	FDE140KXE6D
Nominal cooling capacity	kW	3.6	4.5	5.6	7.1	11.2	14.0
Nominal heating capacity	kW	4.0	5.0	6.3	8.0	12.5	16.0
Power source		1 Phase 220-240V, 50Hz					
Power consumption	Cooling	0.04-0.05			0.08-0.09	0.12-0.14	0.14-0.15
	Heating	0.04-0.05			0.07-0.08	0.11-0.13	0.13-0.14
Sound pressure level **	dB(A)	Hi:39 Me:38 Lo:36			Hi:41 Me:39 Lo:37	Hi:44 Me:41 Lo:39	Hi:46 Me:44 Lo:43
Exterior dimensions H x W x D	mm	210 x 1070 x 690			210 x 1320 x 690	250 x 1620 x 690	
Net weight	kg	28			37	49	
Air flow **	CMM	Hi:11 Me:9 Lo:7			Hi:18 Me:14 Lo:12	Hi:26 Me:23 Lo:21	Hi:29 Me:26 Lo:23
Outside air intake		Not possible					
Air filter, Q'ty		Pocket Plastic net x2 (Washable)					
Remote control(option)		wired:RC-E4, RCH-E3 wireless:RCN-E-E					
Installation data Refrigerant piping size	mm(in)	Liquid line:ø6.35(1/4") Gas line:ø12.7(1/2")			Liquid line:ø9.52(3/8") Gas line:ø15.88(5/8")		

1. The data are measured under the following conditions(ISO-T1). Cooling: Indoor temp. of 27°CDB, 19°CWB, and outdoor temp. of 35°CDB. Heating: Indoor temp. of 20°CDB, and outdoor temp. of 7°CDB, 6°CWB.
 2. Sound pressure level indicates the value in an anechoic chamber. During operation these values are somewhat higher due to ambient conditions.

** Powerful-Hi can be selected. Sound pressure level: FDE36/45/56 46dB(A), FDE71 50dB(A), FDE112 46dB(A), FDE140 50dB(A). Air flow: FDE36/45/56 13CMM, FDE71 22CMM, FDE112 28CMM, FDE140 32CMM.

Dimensions

All measurements in mm.

FDE36KXE6D, 45KXE6D, 56KXE6D

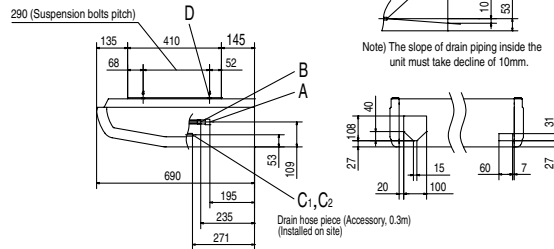
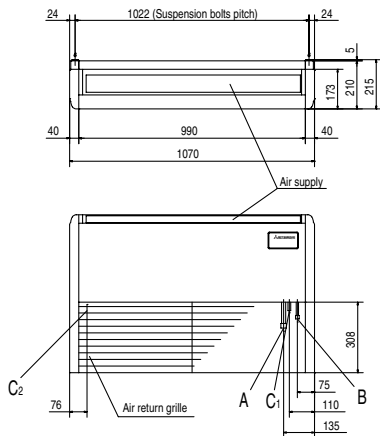

Symbol	Content
A	Gas piping $\phi 12.7$ (1/2") (Flare)
B	Liquid piping $\phi 6.35$ (1/4") (Flare)
C _{1,2}	Drain piping VP20 (I.D.20)
D	Hole for suspension bolt (M10 or M8)
E	Back cutout PE cover
F	Top cutout Plate cover
G	Hole for drain piping (for left back) (Knock out)

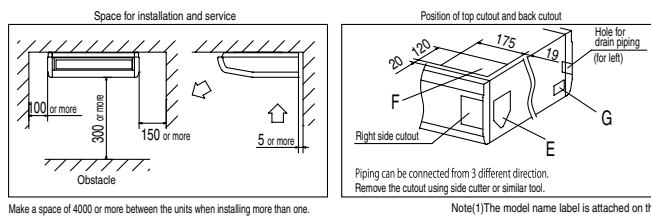

Make a space of 4000 or more between the units when installing more than one.

Note(1) The model name label is attached on the fan casing inside the air return grille.

FDE71KXE6D

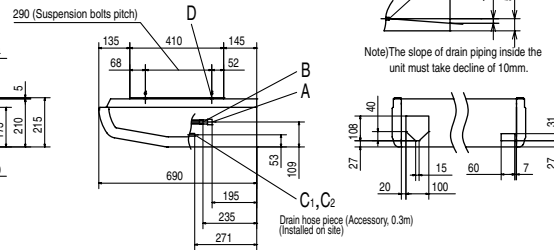
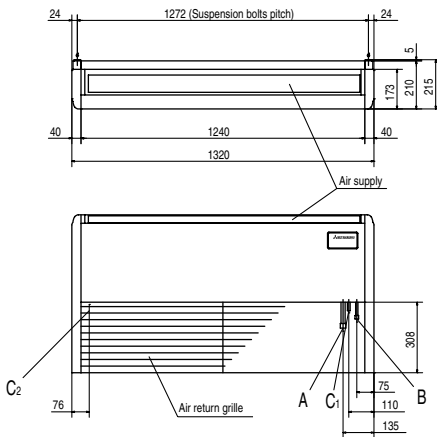

Symbol	Content
A	Gas piping $\phi 15.88$ (5/8") (Flare)
B	Liquid piping $\phi 9.52$ (3/8") (Flare)
C _{1,2}	Drain piping VP20 (I.D.20)
D	Hole for suspension bolt (M10 or M8)
E	Back cutout PE cover
F	Top cutout Plate cover
G	Hole for drain piping (for left back) (Knock out)

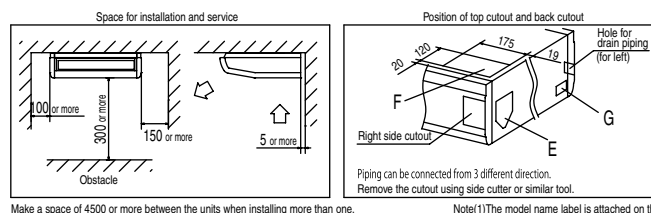

Make a space of 4500 or more between the units when installing more than one.

Note(1) The model name label is attached on the fan casing inside the air return grille.

FDE112KXE6D, 140KXE6D

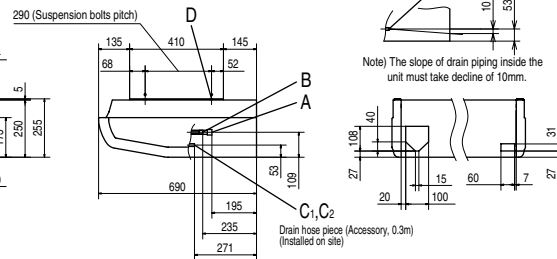
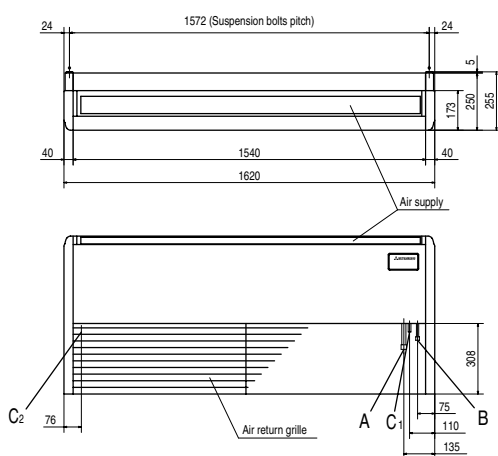

Symbol	Content
A	Gas piping $\phi 15.88$ (5/8") (Flare)
B	Liquid piping $\phi 9.52$ (3/8") (Flare)
C _{1,2}	Drain piping VP20 (I.D.20)
D	Hole for suspension bolt (M10 or M8)
E	Back cutout PE cover
F	Top cutout Plate cover
G	Hole for drain piping (for left back) (Knock out)

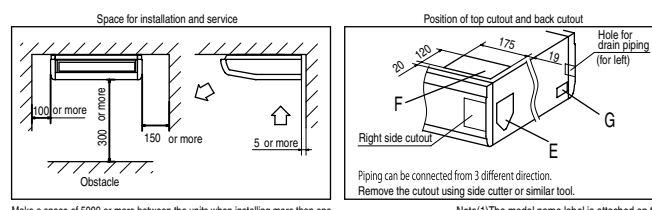

Make a space of 5000 or more between the units when installing more than one.

Note(1) The model name label is attached on the fan casing inside the air return grille.



Floor Standing -2way- FDFW

Model No.
 FDFW28KXE6D
 FDFW45KXE6D
 FDFW56KXE6D



Wired remote control
RC-E4 (option) **RCH-E3 (option)**

Wireless remote control
RCN-FW-E

Sophisticated Design

With classy semi flat front panel in chic white, the new series fit in various kinds of rooms and create relaxing atmosphere. Choice of wall hanging, floor standing or behind gallery installation is available.

Quiet Operation

Thanks to optimum balance of air outlet direction and sufficient air flow volume, the sound level has been minimized. The level of FDFW28KXE6D in the cooling lo mode is 30dB(A) only.

Flap control system

Selection of flap position is possible. A flap can be set at different angles.

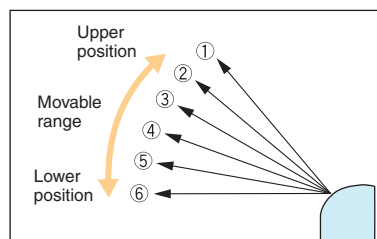

*RCH-E3 is not applicable to the Flap control system.

Convenient to use operation

Simultaneous lower and upper air outlets or upper outlet can be selected by air flow direction button. Further control can be arranged by a remote control.

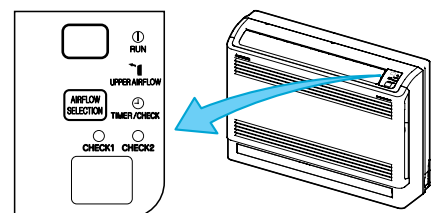

(In case of use of wireless remote control)

Specifications

Item	Model	FDFW28KXE6D	FDFW45KXE6D	FDFW56KXE6D
Nominal cooling capacity	kW	2.8	4.5	5.6
Nominal heating capacity	kW	3.2	5.0	6.3
Power source		1 Phase 220-240V, 50Hz		
Power consumption	Cooling	0.02-0.02	0.03-0.03	0.05-0.05
	Heating	0.02-0.02	0.03-0.03	0.05-0.05
Sound pressure level	dB(A)	Hi:36 Me:34 Lo:30	Hi:38 Me:36 Lo:33	Hi:44 Me:37 Lo:33
Exterior dimensions H x W x D	mm	600x860x238		
Net weight	kg	19	20	
Air flow (Standard)	CMM	Hi:9 Me:8 Lo:7		Hi:11 Me:9 Lo:8
Air filter, Q'ty		Polypropylene net x1 (Washable)		
Remote control(option)		wired:RC-E4, RCH-E3 wireless:RCN-FW-E		
Installation data Refrigerant piping size	mm(in)	Liquid line:ø6.35(1/4") Gas line:ø9.52(3/8")	Liquid line:ø6.35(1/4") Gas line:ø12.7(1/2")	

1. The data are measured under the following conditions(ISO-T1). Cooling: Indoor temp. of 27°CDB, 19°CWB, and outdoor temp. of 35°CDB. Heating: Indoor temp. of 20°CDB, and outdoor temp. of 7°CDB, 6°CWB.
 2. Sound pressure level indicates the value in an anechoic chamber. During operation these values are somewhat higher due to ambient conditions.

Dimensions

All measurements in mm.

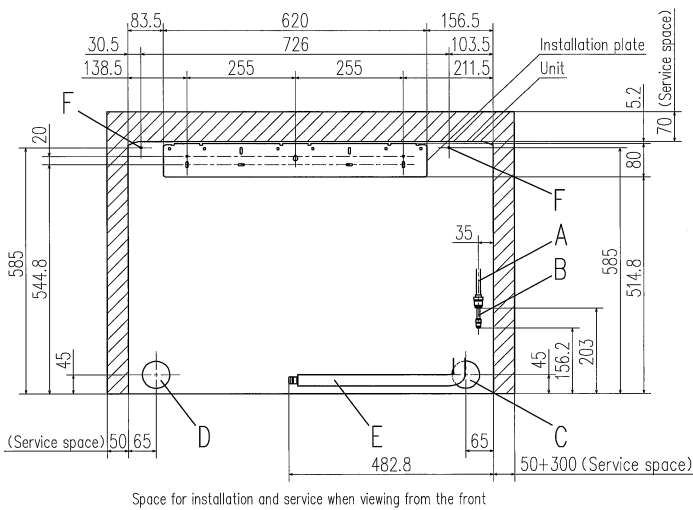
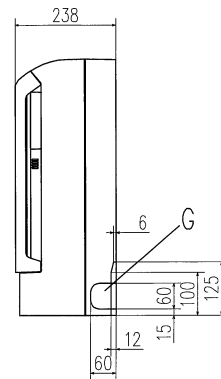
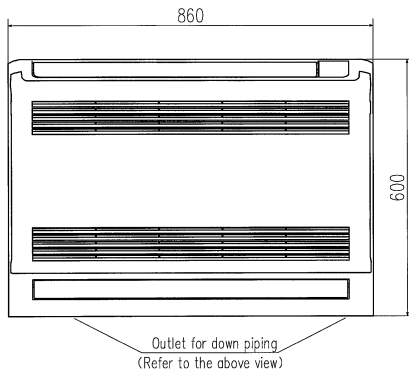
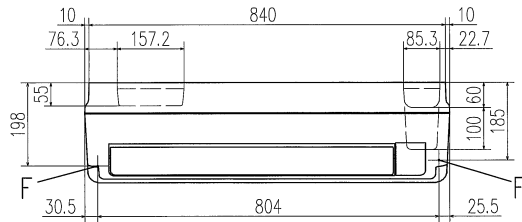

Symbol	Content	
	Model	Content
A	Gas piping	FDW28KXE6D FDFW45KXE6D,56KXE6D $\phi 9.52$ (3/8") (Flare) $\phi 12.7$ (1/2") (Flare)
B	Liquid piping	$\phi 6.35$ (1/4") (Flare)
C	Hole on wall for right rear piping	($\phi 65$)
D	Hole on wall for left rear piping	($\phi 65$)
E	Drain hose	VP16 (I.D.16)
F	Screw point fasten the indoor unit	$\phi 5$
G	Outlet for piping (on both side)	

- Notes
- (1) The model name label is attached on the rightside of the unit.
 - (2) In case of wall installation, leave the unit 150mm or less from the floor.



Floor Standing (with casing)
 FDFL
 Floor Standing (without casing)
 FDFU

Wired remote control



RC-E4 (option) RCH-E3 (option)

Wireless remote control



RCN-KIT3-E (option)

- Model No.**
 FDFL71KXE6D
 FDFU28KXE6D
 FDFU45KXE6D
 FDFU56KXE6D
 FDFU71KXE6D



FDFL

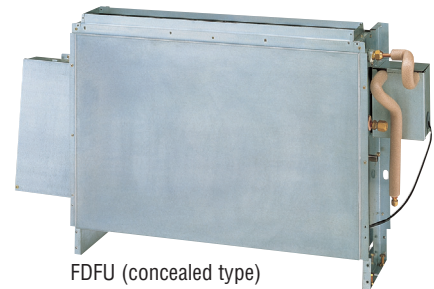

FDFU (concealed type)



Compact design at 630mm height

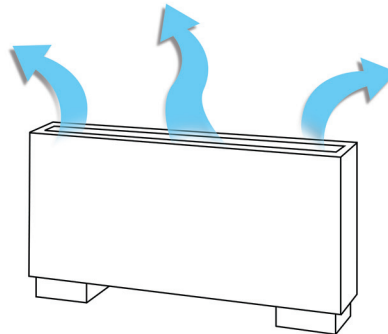

Wider airflow for optimum comfort

Specifications

Item	Model	FDFL71KXE6D	FDFU28KXE6D	FDFU45KXE6D	FDFU56KXE6D	FDFU71KXE6D
Nominal cooling capacity	kW	7.1	2.8	4.5	5.6	7.1
Nominal heating capacity	kW	8.0	3.2	5.0	6.3	8.0
Power source		1 Phase 220-240V, 50Hz				
Power consumption	Cooling	0.09-0.10		0.09-0.10		
	Heating	0.09-0.10		0.09-0.10		
Sound pressure level	dB(A)	Hi:43 Me:41 Lo:40	Hi:41 Me:38 Lo:36	Hi:43 Me:41 Lo:40		
Exterior dimensions H x W x D	mm	630x1481x225	630x1077x225			630x1362x225
Net weight	kg	40	25			32
Air flow (Standard)	CMM	Hi:18 Me:15 Lo:12	Hi:12 Me:11 Lo:10	Hi:14 Me:12 Lo:10		Hi:18 Me:15 Lo:12
Air filter, Q'ty		Polypropylene net x1 (Washable)				
Remote control(option)		wired:RC-E4, RCH-E3 wireless:RCN-KIT3-E				
Installation data		Liquid line:ø9.52(3/8") Gas line:ø15.88(5/8")	Liquid line:ø6.35(1/4") Gas line:ø9.52(3/8")	Liquid line:ø6.35(1/4") Gas line:ø12.7(1/2")		Liquid line:ø9.52(3/8") Gas line:ø15.88(5/8")
Refrigerant piping size	mm(in)					

1. The data are measured under the following conditions(ISO-T1). Cooling: Indoor temp. of 27°CDB, 19°CWB, and outdoor temp. of 35°CDB. Heating: Indoor temp. of 20°CDB, and outdoor temp. of 7°CDB, 6°CWB.
 2. Sound pressure level indicates the value in an anechoic chamber. During operation these values are somewhat higher due to ambient conditions.

Dimensions

All measurements in mm.

FDFL

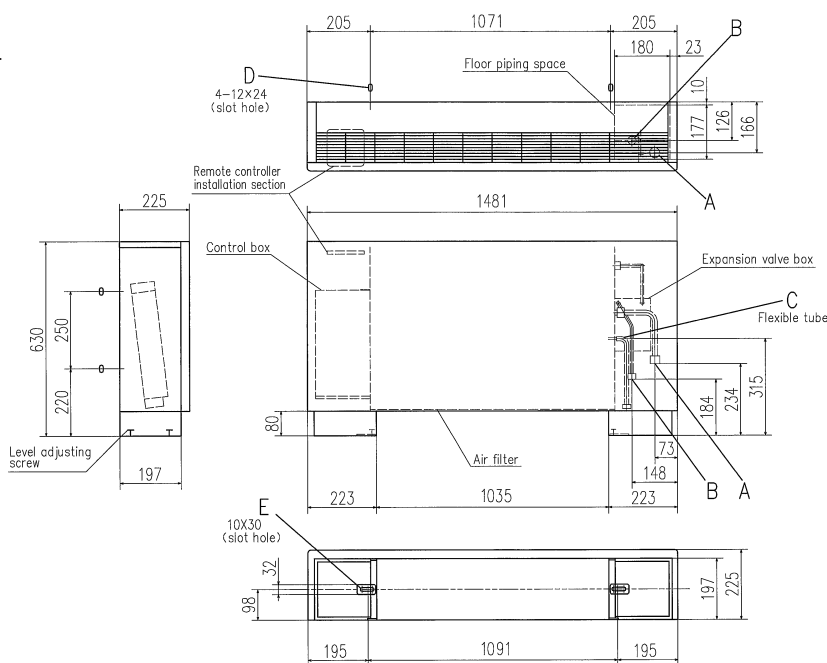

Symbol	Content	
	Model	FDFL71KXE6D
A	Gas piping (Accessory)	φ15.88 (5/8") (Flare)
B	Liquid piping	φ9.52 (3/8") (Flare)
C	Drain piping (Accessory)	PT20A female screw, 360mm
D	Slot hole for wall mounting	(M10)
E	Metal plate for floor mounting (Accessory)	(M8)

Note (1) The model name label is attached on the lid of the control box.

Space for installation and service

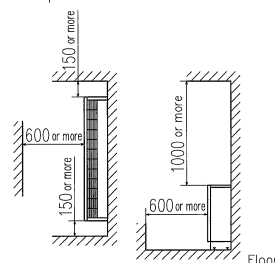

FDFU

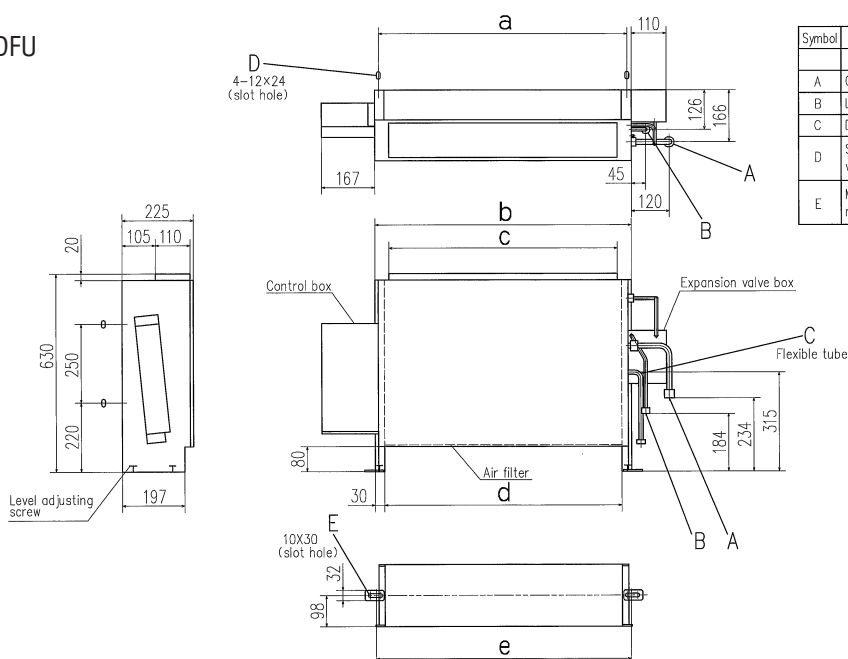

Symbol	Content			
	Model	FDFU28KXE6D	FDFU45KXE6D, 56KXE6D	FDFU71KXE6D
A	Gas piping (Accessory)	φ9.52 (3/8") (Flare)	φ12.7 (1/2") (Flare)	φ15.88 (5/8") (Flare)
B	Liquid piping	φ6.35 (1/4") (Flare)		φ9.52 (3/8") (Flare)
C	Drain piping (Accessory)	PT20A female screw, 360mm		PT20A female screw, 360mm
D	Slot hole for wall mounting	(M10)		(M10)
E	Metal plate for floor mounting (Accessory)	(M8)		(M8)

Note (1) The model name label is attached on the lid of the control box.

Space for installation and service

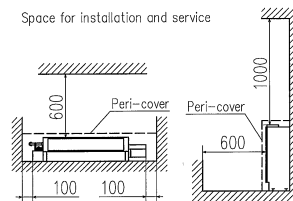

Dimension Table

Unit:mm

model	a	b	c	d	e
FDFU28KXE6D, 45KXE6D, 56KXE6D	786	810	722	750	806
FDFU71KXE6D	1071	1095	1007	1035	1091



Fresh Air Ventilation and Heat Exchange unit SAF-E4

- Model No.**
 SAF250E4
 SAF350E4
 SAF500E4
 SAF800E4
 SAF1000E4



Re; Building Regulations Part L2

The Part L2 (April 2006) regulations limit the amount of electrical/gas power to be used to provide heating or cooling in commercial buildings. Therefore the building designer needs to select energy efficient heating/cooling equipment, and to minimise energy losses through ventilation systems.

The SAF recovers heat energy which would otherwise be exhausted to atmosphere, and uses this energy to warm the air entering the building. The reverse happens in warmer climates, where the exhausted cool air is used to partially cool the incoming air.

Capturing this waste energy, means the heating/cooling requirements of the building are reduced, so smaller size plant can be selected, savings can be made in long term energy consumption, and carbon emissions are reduced.

The inclusion of the SAF energy recovery ventilation units in the building design, will reduce the total amount of carbon emissions.

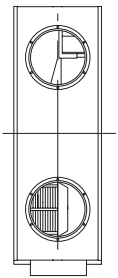

Structure (SAF1000E4)

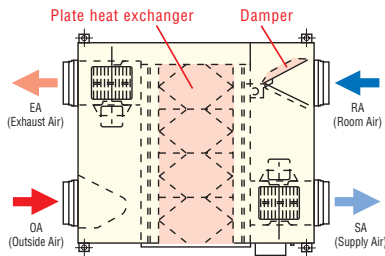

Principle of operation (simple ventilation)

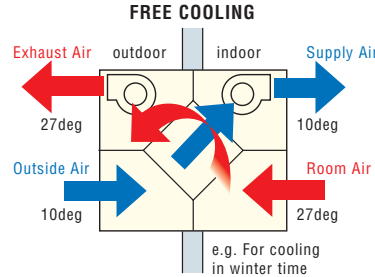

Principle of operation (heat exchanging)

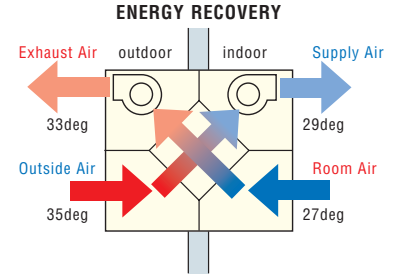

Specifications

Item	Model	SAF250E4	SAF350E4	SAF500E4	SAF800E4	SAF1000E4		
Power source		1 Phase 220-240V, 50Hz						
Exterior dimensions Height x Width x Depth	mm	270x882x599	270x882x804	270x962x904	388x1322x884	388x1322x1135		
Exterior appearance		Galvanised steel sheet						
Capacity	UHi	Power input	W	99-114	124-137	169-188	309-359	360-399
		Running current	A	0.46-0.48	0.59-0.60	0.79-0.81	1.48-1.50	1.85-1.93
		Enthalpy exchange efficiency Cooling	%	63	66	62		65
	Hi	Enthalpy exchange efficiency Heating		70	69	67		71
		Temperature exchange efficiency				75		
		Enthalpy exchange efficiency Cooling		63	66	62		65
	Lo	Enthalpy exchange efficiency Heating		70	69	67		71
		Temperature exchange efficiency				75		
		Enthalpy exchange efficiency Cooling		66	69	77	68	68
Motor & Q'ty	kW	0.02x2	0.044x2	0.062x2	0.117x2	0.137x2		
Air handling equipment Fan type & Q'ty		Sirocco fan x 2						
Air flow	UHi	m³/h	250	350	500	800	1000	
	Hi		250	350	500	800	1000	
	Lo		170	280	370	650	810	
Available static pressure	UHi	Pa	90	95	105	140	90	
	Hi		80	65	70	110	55	
	Lo		37	42	38	70	35	
Remote control		Standard equipment						
Air filter	Out take intake air		Protection for element (Washable) PS400					
	Exhaust air							

Dimensions

All measurements in mm.

SAF250E4,350E4,500E4

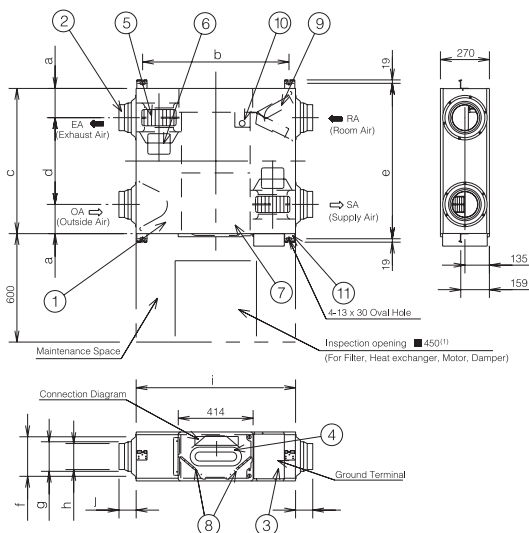

SAF800E4

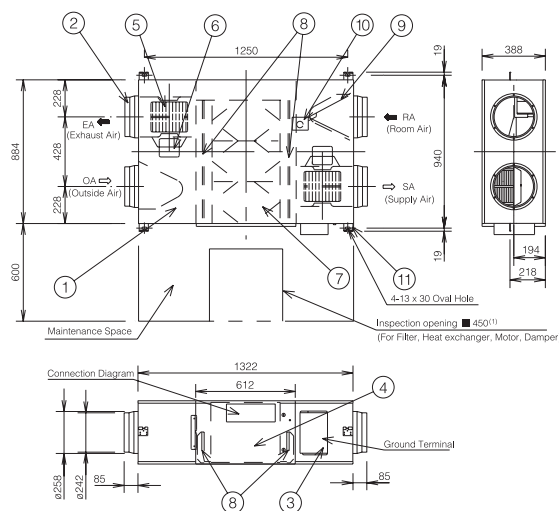

SAF1000E4

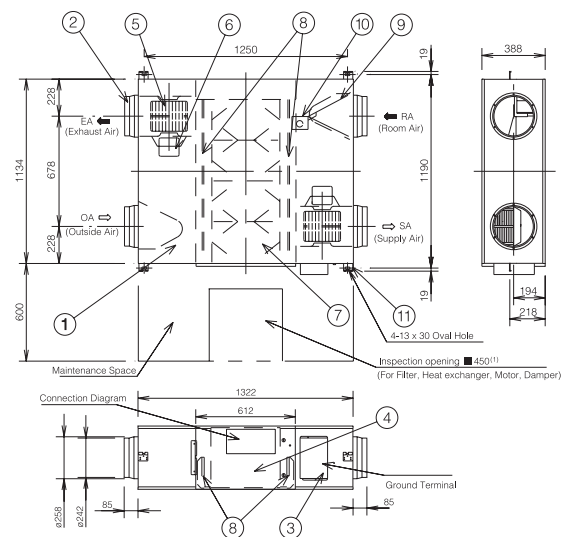

Installation reference

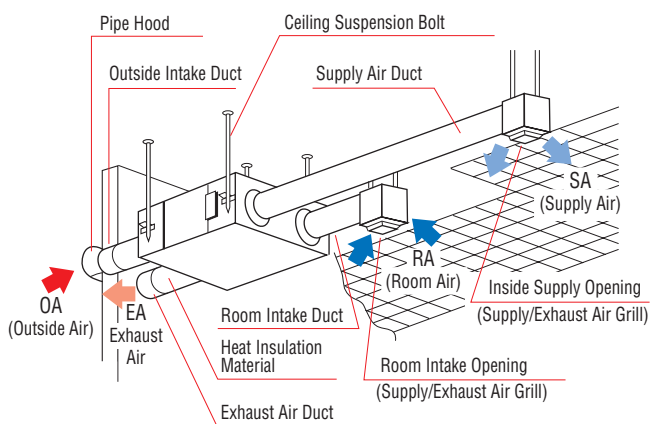

NO.	Name	Quantity	Material	Remarks
1	Frame	1	Zinc-plated steel	
2	Adaptor	4	ABS Resin	
3	Electrical Equipment Box	1		
4	Inspection Cover	1	Zinc-plated steel	
5	Fan	2	ABS Resin	
6	Motor	2		
7	Heat Exchange Element	2	Flame Retardant Paper + Plastic	Air to air Heat Exchanger
8	Filter	2	Non-woven Cloth	Collection Efficiency Gravimetric Method 82%
9	Damper	1		
10	Damper Motor	1		
11	Ceiling Suspension Fixture	4	Zinc-plated Steel	

Dimension table

Unit:mm

Model	a	b	c	d	e
SAF250E4	142	810	599	315	655
SAF350E4	162	810	804	480	860
SAF500E4	202	890	904	500	960

Model	f	g	h	i	j
SAF250E4	ø219	ø164	ø144	882	95
SAF350E4	ø219	ø164	ø144	882	95
SAF500E4	ø246	ø210	ø194	962	107

Note(1) An inspection port is needed for cleaning the heat exchanger and filter 1 or 2 times a year.





Fresh Air DX Assembly

Model No.
 SAF-DX250E6
 SAF-DX350E6
 SAF-DX500E6
 SAF-DX800E6
 SAF-DX1000E6

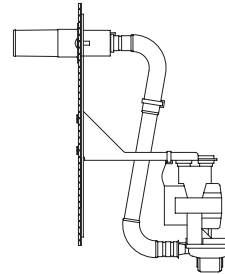

Drain up kit (600mm)
DXA-DU-E(option, built-in type)



Wired remote control

RC-E4 (option) RCH-E3 (option)

Wireless remote control

RCN-KIT3-E (option)

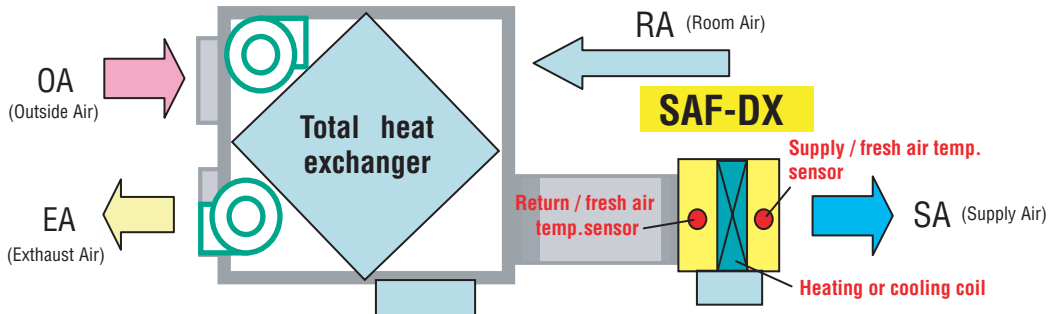
- SAF-DX is a heating or cooling coil incorporating MHI KX6 series controls. It can be used in combination with our SAF series of total heat exchanger.
- Combination of SAF-DX together with other KX6 indoor units is possible. The capacity code index of each model is shown below and must be used when making the system selection. Total capacity code index must be within 100% of outdoor unit capacity code index.
- Remote control option is the same as with other KX6 indoor units (see above). Connection to all superlink controls is also possible.
- Optional condensate lift mechanism is also available (600mm height).
- Return air temp. control or supply air temp. control can be selectable.



SAF-DX can provide heating or cooling to the fresh air supplied through a 3rd party air handling unit or total heat exchanger such as our SAF series.

Specifications

Item	Model	SAF-DX250E6	SAF-DX350E6	SAF-DX500E6	SAF-DX800E6	SAF-DX1000E6
Nominal cooling capacity *1	kW	2.0	2.8	3.6	5.6	6.3
Nominal heating capacity *2	kW	1.8	2.2	2.8	4.5	5.6
Capacity code		22	28	36	56	63
Power source		1 Phase 220-240V, 50Hz				
Power consumption	Cooling	7.2				
	Heating	7.2				
Running current	Cooling	0.05				
	Heating	0.05				
Exterior dimensions H x W x D	mm	315 x 452 x 422		315 x 537 x 422	315 x 682 x 422	315 x 822 x 422
Net weight	kg	12.3		13.6	16.1	18.4
Air flow (Standard)	CMH	250	350	500	800	1000
Internal resistance	Pa	38				
Remote control(option)		wired: RC-E4, RCH-E3 wireless: RCN-KIT3-E				
Installation data Refrigerant piping size	mm(m)	Liquid line:ø6.35(1/4") Gas line:ø9.52(3/8")		Liquid line:ø6.35(1/4") Gas line:ø12.7(1/2")		Liquid line:ø9.52(3/8") Gas line:ø15.88(5/8")

(1) The data are measured at the following conditions.

Item	Return/fresh air temperature		Outdoor air temperature		Standards
	DB	WB	DB	WB	
Cooling*1	27°C	19°C	35°C	24°C	ISO-T1
Heating*2	20°C		7°C	6°C	

(2) This air-conditioner is manufactured and tested in conformity with ISO-T1 "UNITARY AIR-CONDITIONERS".

Dimensions

All measurements in mm.

SAF-DX250E6,350E6

Symbol	Content
A	Gas piping $\phi 9.52 (3/8")$ (Flare)
B	Liquid piping $\phi 6.35 (1/4")$ (Flare)
C	Drain piping VP20
D	Hole for power source line
E	Wiring hole for total enthalpy heat exchanger
F	Hole for communication line
G	Suspension bolts M10

Space for installatin and service

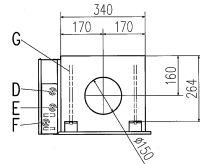
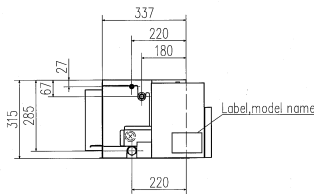
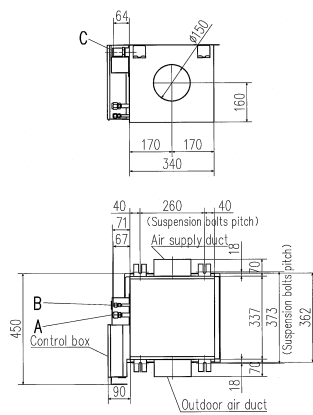
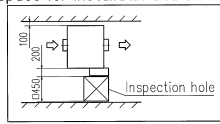

SAF-DX500E6

Symbol	Content
A	Gas piping $\phi 12.7 (1/2")$ (Flare)
B	Liquid piping $\phi 6.35 (1/4")$ (Flare)
C	Drain piping VP20
D	Hole for power source line
E	Wiring hole for total enthalpy heat exchanger
F	Hole for communication line
G	Suspension bolts M10

Space for installatin and service

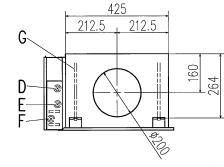
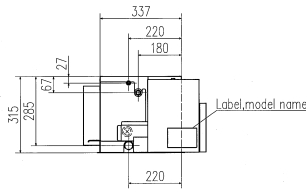
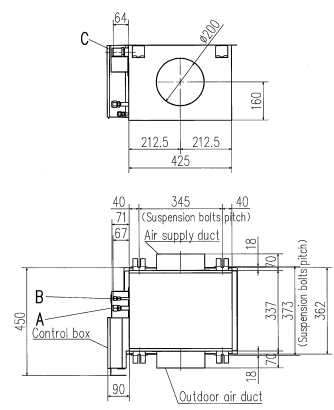
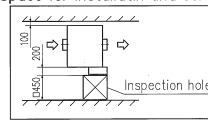

SAF-DX800E6

Symbol	Content
A	Gas piping $\phi 12.7 (1/2")$ (Flare)
B	Liquid piping $\phi 6.35 (1/4")$ (Flare)
C	Drain piping VP20
D	Hole for power source line
E	Wiring hole for total enthalpy heat exchanger
F	Hole for communication line
G	Suspension bolts M10

Space for installatin and service

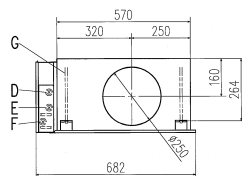
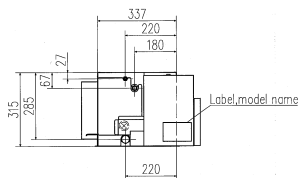
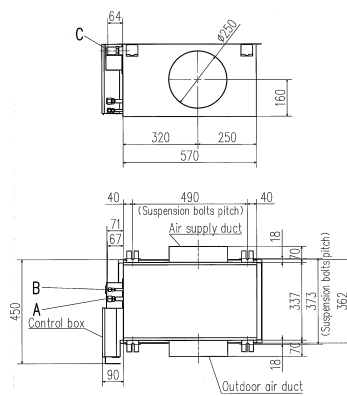
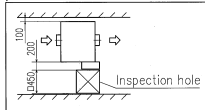

SAF-DX1000E6

Symbol	Content
A	Gas piping $\phi 15.88 (5/8")$ (Flare)
B	Liquid piping $\phi 9.52 (3/8")$ (Flare)
C	Drain piping VP20
D	Hole for power source line
E	Wiring hole for total enthalpy heat exchanger
F	Hole for communication line
G	Suspension bolts M10

Space for installatin and service

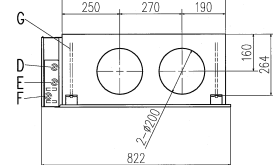
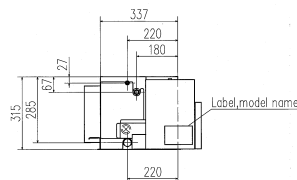
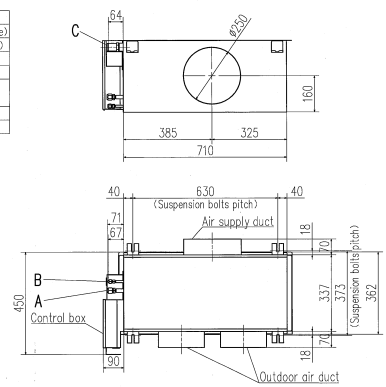
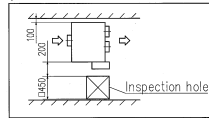



Outdoor Air Processing unit FDU-F

Model No.
 FDU500FKXE6D
 FDU850FKXE6D
 FDU1300FKXE6D
 FDU1800FKXE6D

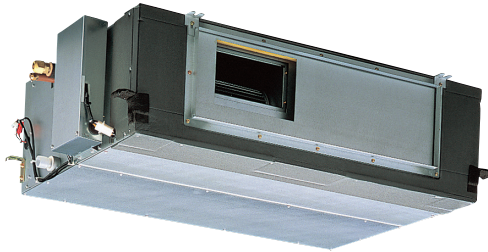

Fan control kit
(100~200Pa)
U-FCRB(option)

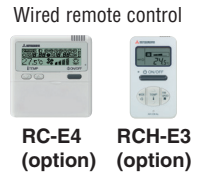

Air conditioning and intake of outdoor air are in the same system

Outdoor Air processing unit can be connected in a KX6 system as one of indoor unit series and can create fresh and comfortable air supply together from our high advanced technology.

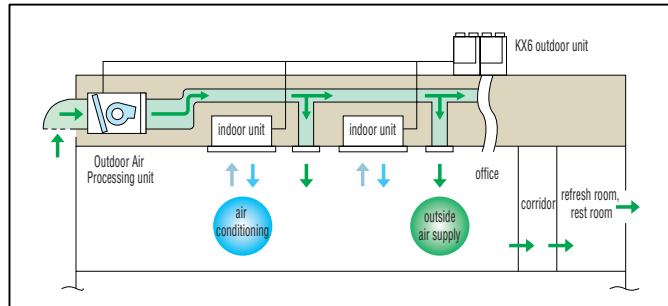

Compact design

Compact design at just 360mm in height, high static pressure of 200Pa and the industry's lowest noise level can meet various kind of installation location for office, refresh room, restroom and kitchen of restaurant etc.

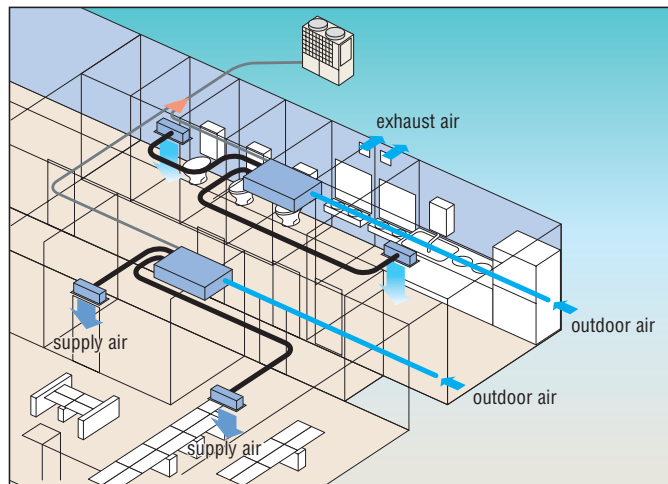

- (1) This unit is the specific unit for processing the outdoor air temperature closer to the room temperature. For conditioning the room temperature a dedicated air-conditioner is required additionally.
- (2) This unit monitors the outdoor air temperature and controls thermostat ON/OFF at the setting temperature by the remote controller, which indicates the outdoor air temperature for controlling thermostat ON/OFF. When thermostat is turned OFF, the operation is changed to the fan mode so that unprocessed outdoor air will be blown into the room directly. Therefore place the air outlet port or orient the air outlet direction not to blow air directly to persons in the room, especially in the small room such as a restroom and/or sanitary hot water supplying room.
- (3) It is strictly prohibited to monitor the room temperature by switching to the thermistor at remote controller side and/or the optional remote thermistor. Otherwise dew formation at air outlet port and/or dew dripping may occur during cooling operation due to the lower outdoor air temperature. Therefore keep the remote controller of this unit in place closer to the administrator so as not to be touched it freely by the end user.
- (4) Dehumidifying operation with this unit is prohibited.
- (5) When handing over this unit to the end user, make sure to explain sufficiently about the foregoing cautions, the installation place and usage of remote control for this unit and the location of the air outlet.

Connectivity with KX6 series

FDU-F series are connectable to 8~48HP KX6 outdoor units, not connectable to 4~6HP.
 8 ~ 48 HP : Yes , 4 ~ 6 HP : No

Combination with KX6 series

	case	Combination
A	In case OA processing units only are connected with KX6 outdoor units	The total capacity of FDU-F is 50~100% of outdoor capacity and max quantity of FDU-F is 2 units.
B	In case both of OA processing units and dedicated air-conditioner are connected with KX6 outdoor unit.	The total capacity of FDU-F and dedicated air-conditioners is 50~100% of outdoor capacity and max quantity of FDU-F should be below 30% of outdoor unit capacity.

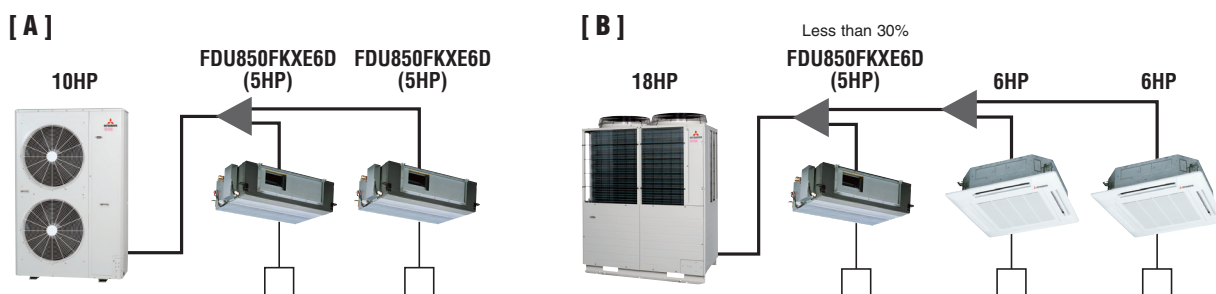

Concept (Difference between FDU-F and SAF)

SAF is the energy recovery ventilation unit which can recover heat energy from exhaust air to supply air and "has no air processing function, but FDU-F is air processing unit which can treat the supply air closer to room temperature by cooling or heating in connection with KX6 refrigerant system and exhaust air is discharged to outside of the room.

FDU-F OA Processing units

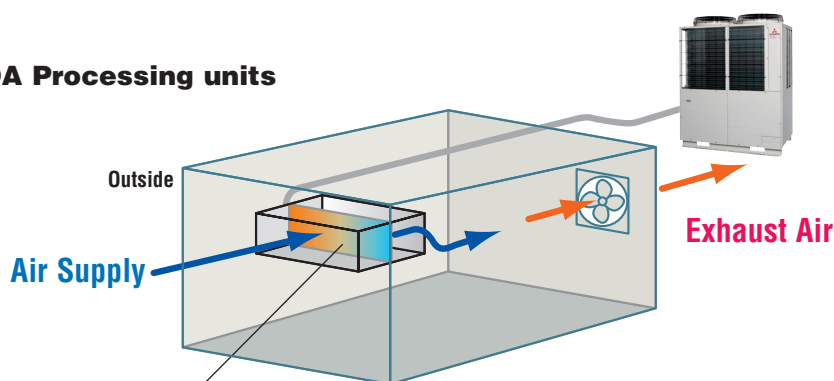

SAF

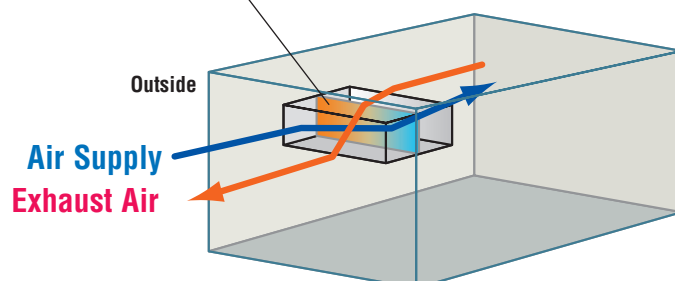



Specifications

Item	Model	FDU500FKXE6D	FDU850FKXE6D	FDU1300FKXE6D	FDU1800FKXE6D
Nominal cooling capacity	kW	9.0	14.0	22.4	28.0
Nominal heating capacity	kW	4.2	7.0	10.9	14.8
Power source		1 Phase 220-240V, 50Hz			
Power consumption	Cooling	0.11	0.16	0.27	0.31
	Heating	0.11	0.16	0.27	0.31
Sound pressure level	dB(A)	38	41	43	46
Exterior dimension HxWxD	mm	360x820x830		360x1570x830	
Net weight	kg	48	62	82	84
Air flow (Standard)	CMM	8.5	14	22	30
	CMH	510	840	1320	1800
External static pressure	Pa	200			
Air filter, Q'ty		Procure locally			
Remote control(option)		wired:RC-E4,RCH-E3 wireless:RCN-KIT3-E			
Installation data	mm	Liquid line:ø9.52(3/8")		Liquid line:ø9.52(3/8")	
	(in)	Gas line:ø15.88(5/8")		Gas line:ø19.05(3/4")	

- The data are measured at 33°CDB 28°CWB (68%RH) during cooling and 0°CDB-2.9°CWB (50%RH) during heating (no frost). External static pressure of indoor unit with optional fan controlling kit "U-FCRB" is 100Pa.
- Temperature range of outdoor air must be 20~40°CDB (32°CWB) during cooling and -10~24°CDB during heating.
- Operation sound is measured in an anechoic room based on JIS standard. In case of actual room installation, it usually becomes higher than the displayed value due to the surrounding noise and echo.
- The total connection capacity of the other standard air conditioning units and the outdoor air processing units must be from 50% to 100% (the total includes the outdoor air processing unit). The connection capacity of the outdoor air processing unit must not exceed 30% of the capacity of the outdoor unit.
- Single outdoor air processing unit can be used alone. The connection capacity of the outdoor air processing unit must be from 50% to 100% of the total capacity of the outdoor unit.
- Single outdoor air processing unit can be used alone. Maximum number of outdoor air processing units that can be connected to the outdoor unit is 2units.
- Values of sound pressure level become increased 5dB(A), when external static pressure is 200Pa (factory setting).
- Values of air flow volume are those at external static pressure 200Pa (factory setting).

Dimensions

All measurements in mm.

FDU500FKXE6D

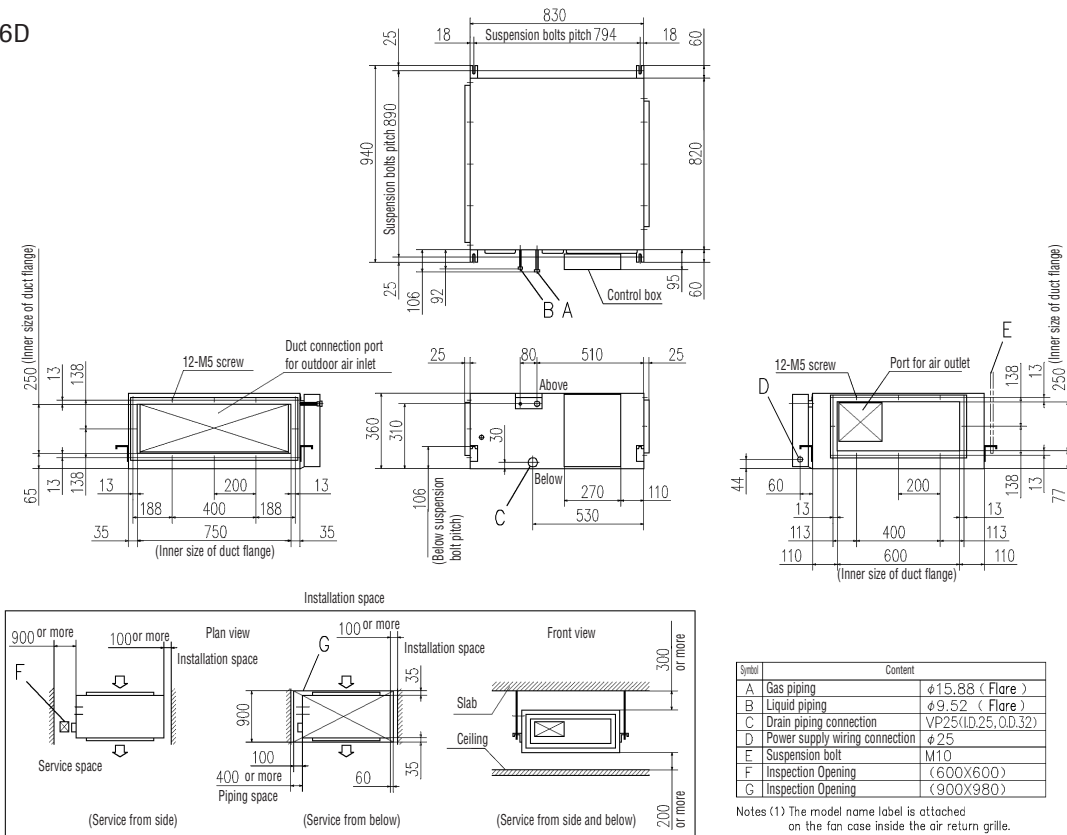

FDU850FKXE6D

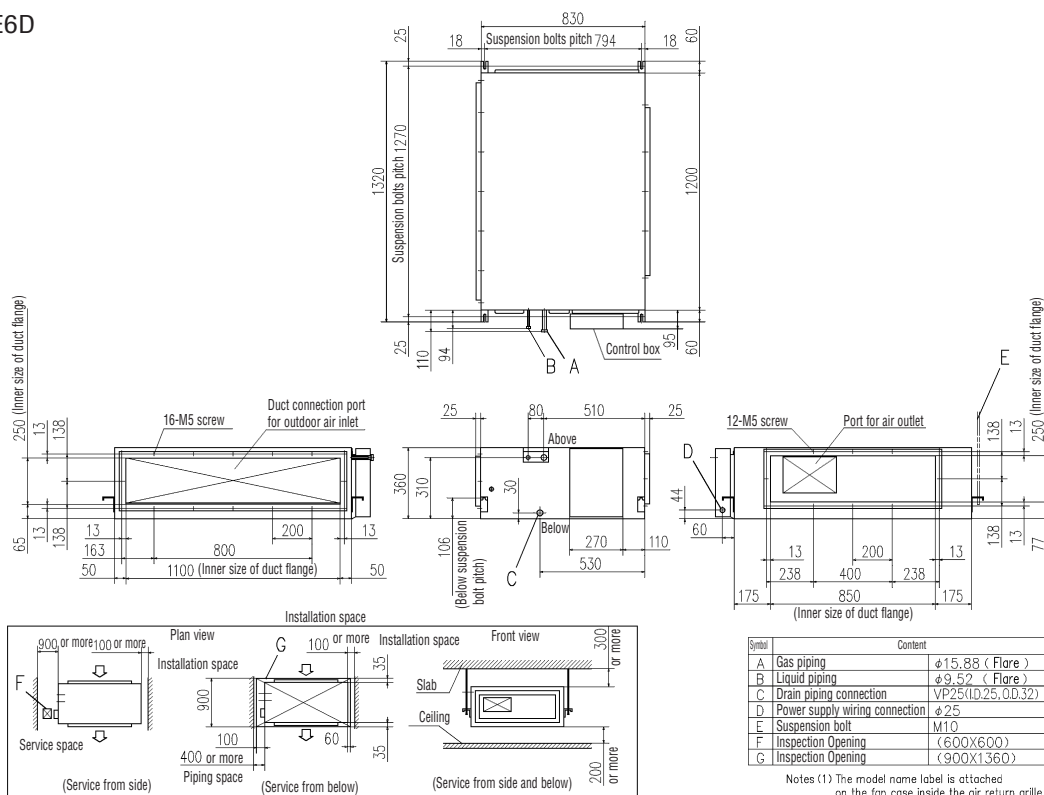

FDU1300FKXE6D, FDU1800FKXE6D

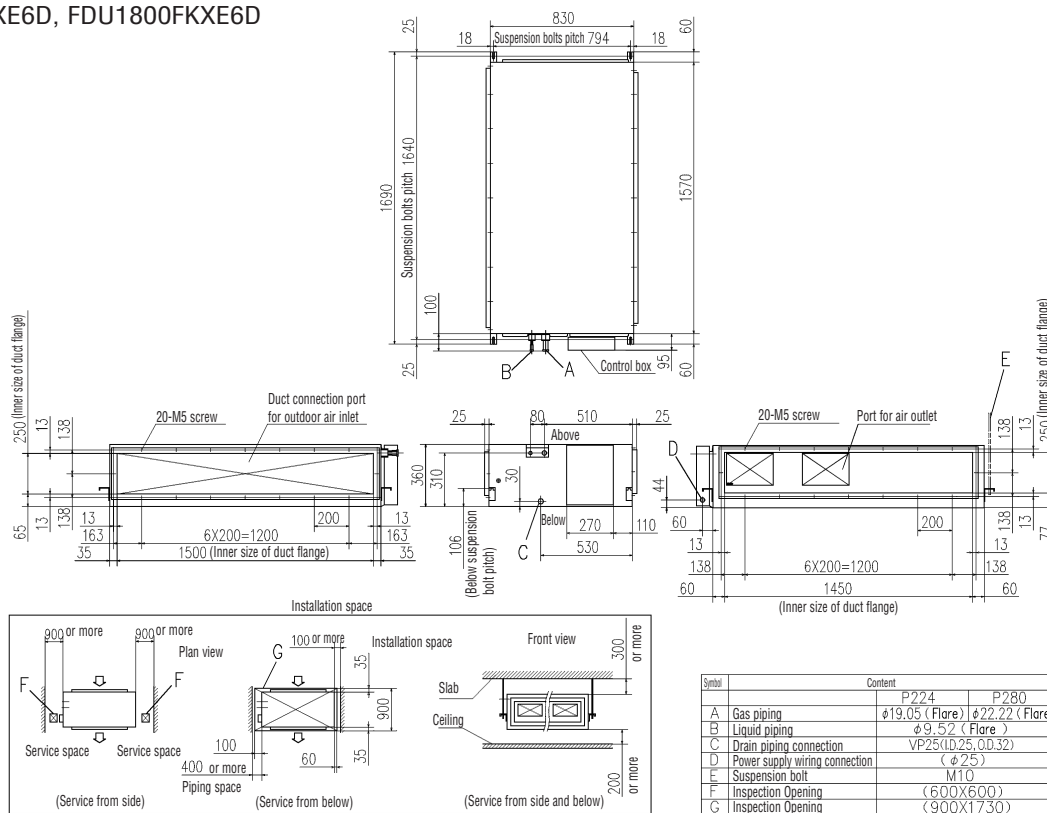



Control Systems

<Individual control>

Remote Control line up (except SAF)

	indoor unit	remote control		indoor unit	remote control	indoor unit	remote control
wired	all models	RC-E4	wireless	FDT	RCN-T-36W-E	FDK22-56	RCN-K-E
		RCH-E3		FDT	RCN-TC-24W-ER	FDK71	RCN-K71-E
				FDE	RCN-E-E	others	RCN-KIT3-E

Wired remote control with weekly timer (option)

RC-E4



The RC-E4 controller enables extensive access to service and maintenance technical data combined with easy to use functions and a clear LCD display.

Weekly timer function as standard

RC-E4 provides (as a standard feature) a weekly timer, which allows one-week operation schedules to be registered. A user can specify up to four times a day to start/stop the air conditioner. (Temperature setting is also possible with the timer).

Timer operation

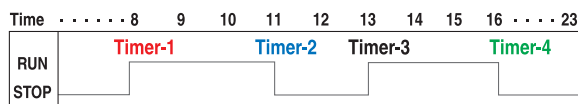

Run hour meters to facilitate maintenance checking

RC-E4 stores operation data when an anomaly occurs and indicates the error on the LCD. It also displays cumulative operation hours of the air conditioner and compressor since commissioning.

Room temperature controlled by the remote control sensor

The temperature sensor is housed in the top section of the remote control unit. This arrangement has improved the sensitivity of the remote control unit's sensor, which permits more finely controlled air conditioning.

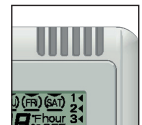

Changeable set temperature ranges

RC-E4 allows the upper and lower limits of a set temperature range to be specified separately. By adjusting a set temperature range, you can ensure energy saving air conditioning by avoiding excessive cooling or heating.

Changeable range	
Upper limit	20-30°C(effective for heating operation)
Lower limit	18-26°C(effective for non-heating operation)

Simple remote control (option)

RCH-E3 (wired)



Considering specialized usage in hotel rooms, control buttons are limited only to minimum required functions such as ON/OFF, mode, temperature setting and fan speed. It is really simple and easy to use.

Up to 16 units

It can control up to 16 units individually, with pressing the AIR CON No. button.

AUTO restart

This function allows starting the air conditioner automatically when power supply is restored after power failure or by turning on the power switch.

* RCH-E3 is not applicable to the Individual flap control system and the Flap control system.
* When RCH-E3 is used, the fan speed setting can only be set to 3 speed settings (Hi-Me-Lo).

Thermistor (option)

SC-THB-E3

In case sensor in the indoor units or the remote control sensor can not sense the room temperature correctly, or individual remote control in each room is not required but only sensor is required (as when center control system is in place), install SC-THB-E3 at proper place in the rooms.



8m

Wireless remote control (option)

For wireless control simply insert the infra-red receiver kit on a corner of the panel

RCN-T-36W-E, RCN-TC-24W-ER



RCN-E-E



RCN-K-E, RCN-K71-E



RCN-FW-E

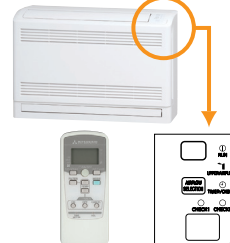

RCN-KIT3-E



* The wireless remote control is not applicable to the Individual flap control system and the Flap control system.
* When the wireless remote control is used, the fan speed setting can only be set to 3 speed settings (Hi-Me-Lo).

<Control System> SUPERLINK-II

MHI has now combined simplicity of installation with our highly sophisticated Superlink-II control system, to offer building owners and occupiers a comprehensive control and management system, while providing complete commissioning and service maintenance assistance for installers and service engineers. The Superlink-II network utilises two wire, non-polar cable - for further details of wiring.

Superlink-II is an advanced high speed data transmission system that can connect up to 128 indoor units and 32 outdoor units as a network. MHI offers a wide range of control options for the Superlink-II network to suit any application large or small, as well as connection to new or existing building management systems. Individual MHI split systems can also be integrated on to the Superlink-II network using SC-ADNA-E.

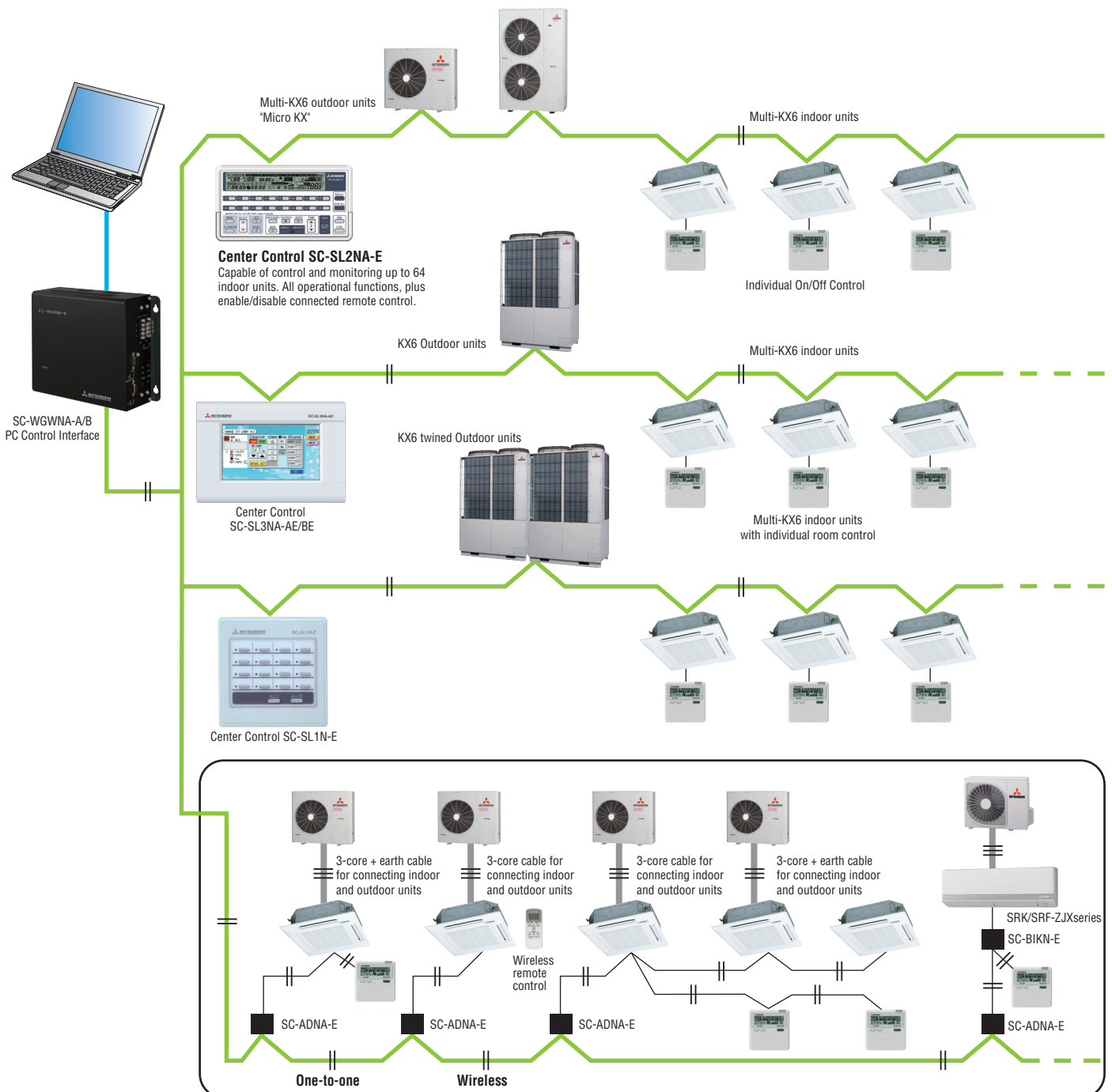



<Central Control>

SC-SL1N-E

Start/stop control of up to 16 indoor units either individually or collectively.

Simple centralised control.

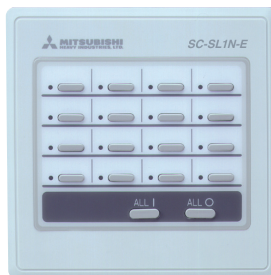

1. The SC-SL1N-E is connected to the Superlink-II network via 2-core, non-polar wires ('AB' connection).
2. It will monitor and control the start/stop function of up to 16 units, with the sixteen operation button.
3. The unit or group numbers in operation or in need of service are displayed with an LED.
4. Collective start/stop is also available through the simultaneous on/off button.
5. Up to 12 SC-SL1N-E units can be connected to a Superlink-II network (consisting of up to 128 indoor units).
6. If a power failure occurs, the SC-SL1N-E will resume the operation of the system according to a stored operation condition, once power is restored.

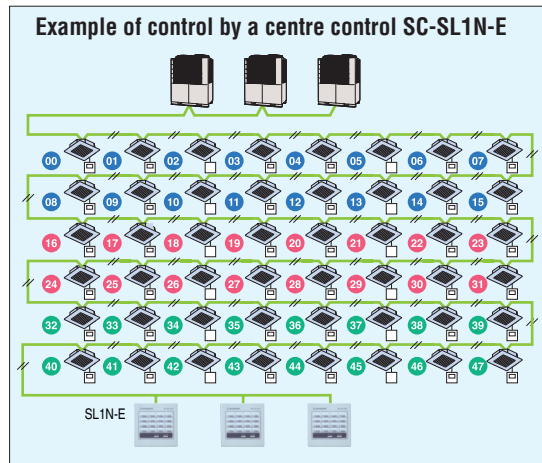

More than one unit (up to 16) can be controlled for individual or collective start/stop operation and indication of unit statuses such as in operation or in need of service.

- Outer dimensions: H120 x W120 x D15+62*mm.
- 62* is the measurement including the part contained in a recess.

SC-SL2NA-E

Central control of up to 64 indoor units including weekly timer function as standard.

1. The SC-SL2NA-E is connected to the Superlink-II network via 2-core, non-polar wires ('AB' connection).
2. It will monitor and control the start/stop function of up to 16 units, or 16 groups of units, with the sixteen operation buttons.
3. It also monitors and controls the following functions for individual units, groups of units or the complete network: operation mode, set point temperature, return air temperature, louvre position, error code. Air flow and center lock function.
4. The unit or group numbers in operation or in need of service are displayed with an LCD.
5. Collective start/stop is also available through the simultaneous on/off button.
6. If a power failure occurs, the SC-SL2NA-E will resume the operation of the system according to a stored operation condition, once power is restored.
7. The SC-SL2NA-E can be connected to an external timer to facilitate timed on/off cycles.
8. The number of units connected to one network are detailed on the table below.

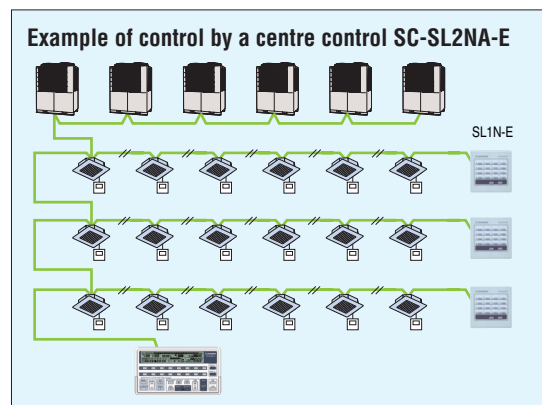
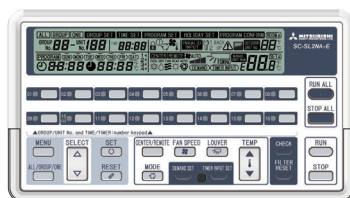

An SC-SL2NA-E performs the start/stop control, monitoring and mode setting of up to 64 units. It is a high quality air conditioner control system that allows up to 64 indoor units to be freely grouped into 1 to 16 groups. It allows not only the start/stop control but also the monitoring, display of operation statuses such as in operation or in need of service and mode setting such as switching of operation modes of connected units collectively, by group or individually.

- Outer dimensions: H120 x W215 x D25+35*mm.
- 35* is the measurement including the part contained in a recess.

Combination of Center Control and BMS interface unit

	SC-SL1N-E	SC-SL2NA-E	SC-SL3NA-AE/BE	SC-WGWNA-A/B	SC-BGWNA-A/B	SC-LGWNA-A
SC-SL1N-E	Yes(*1)	Yes(*1)	Yes(*1)	Yes(*2)	Yes(*2)	Yes(*2)
SC-SL2NA-E	Yes(*1)	Yes(*1)	Yes(*1)	Yes(*2)	Yes(*2)	Yes(*2)
SC-SL3NA-AE/BE	Yes(*1)	Yes(*1)	Yes(*1)	Yes(*2)	Yes(*2)	Yes(*2)
SC-WGWNA-A/B	Yes(*2)	Yes(*2)	Yes(*2)	No	No	No
SC-BGWNA-A/B	Yes(*2)	Yes(*2)	Yes(*2)	No	No	No
SC-LGWNA-A	Yes(*2)	Yes(*2)	Yes(*2)	No	No	No

(*1) Number of units in combination of SC-SL1N-E, SC-SL2NA-E and SC-SL3NA-AE/BE

(*2) Number of units in combination of SC-WGWNA-A/B, SC-BGWNA-A/B, SC-LGWNA-A, SC-SL3NA-AE/BE, SC-SL2NA-E and SC-SL1N-E

SC-SL3NA-AE/BE	Connectable number of controls in one superlink-II network									
	0		1			2				
SC-SL2NA-E	0	1-2	3-4	5-8	0-2	3-4	5-8	0-2	3-4	5-8
SC-SL1N-E	12	8	4	0	8	4	0	8	4	0

Regarding previous Superlink, refer to Technical Manual '06 SC-T-111, '08 SC-T-119.

Connectable number of controls in one superlink-II network			
SC-WGWNA-A/B or SC-BGWNA-A/B or SC-LGWNA-A	SC-SL1N-E	SC-SL2NA-E	SC-SL3NA-AE/BE
1	0-4	0-1	0-1

Regarding previous Superlink, refer to Technical Manual '06 SC-T-111, '08 SC-T-119.

SC-SL3NA-AE/BE

MHI introduces the full colour touch screen central control SC-SL3NA-AE/BE, with 7 inch interactive LCD display. Offers control, monitoring, scheduling and service/maintenance functions for up to 128 indoor units.

Indoor units can be controlled, scheduled, monitored and interrogated either individually, as groups or as blocks of groups with the following functions:

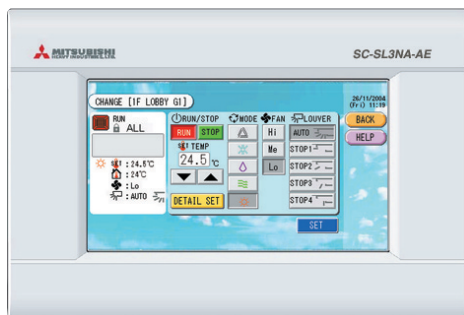

SLA3R-BX Control Box (option)

In case SC-SL3NA-AE/BE is fixed in the wall, use SLA3R-BX as optional parts.

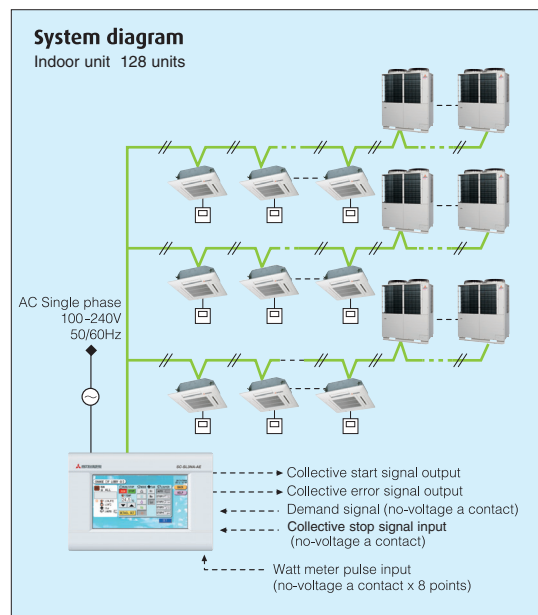
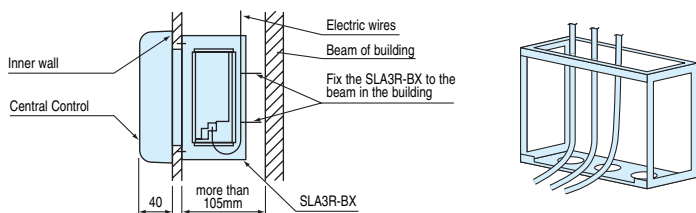

Control	Monitoring	Scheduling	Administration/Service
Run/Stop	Operating state	Yearly schedule	Block definition
Mode (cool/heat/fan)	Mode	Today's schedule	Group definition
Set temperature	Set temperature	Special day schedule	Unit definition
Operation permitted/prohibited	Room temperature		Time and date setting
Fan speeds	Operation enabled		Alarm history
Air direction	Fan speed		Energy consumption calculation period
Filter reset	Air direction		Energy consumption cumulative operation time
Filter sign			
Maintenance (1, 2 or back-up)			Demand control
Breakdown			Emergency stop
			Power failure recovery control

Electric power calculation function:

(for SC-SL3NA-BE only)

SC-SL3NA-BE gives outputs as "electric power consumption kW data -each indoor unit, each group, each SUPERLINK-II system and each power pulse system-" and uses USB memory.

The data can be edited by using the software that comes with the unit.



	SC-SL3NA-BE
Method of data saving	USB
Calculation software	Standard
Air-conditioner power proportional distribution pulse input	8 systems
Connecting indoor units number (Maximum)	128

Item	Model	SC-SL3NA-AE/SC-SL3NA-BE
Ambient temperature during use		0 ~ 40°C
Power supply		1 Phase 100-240V 50/60Hz
Power consumption		18W
External dimensions (Height x Width x Depth)		162mm x 240mm x 108mm
Net weight		2.0kg
Number of connectable units (indoor units)		up to 128 units
LCD touch panel		Colour LCD, 7 inches wide
Inputs	SL (Superlink) signal inputs	3 systems
	Gas, Power pulse input*	8-point pulse width 100ms or more
	Emergency stop signal input*	1 point non-voltage a contact input continuous input (closed, forced stop)
	Demand signal input*	1 point non-voltage a contact input continuous input (closed, demand control)
Outputs	Simultaneous operation output	1 point maximum rated current 40mA, 24 V During full stop; Open. If even one unit is operating; Closed
	Simultaneous error output	1 point maximum rated current 40mA, 24 V Normal; closed. If even one unit is abnormal; Open

* The receiving side power supply is DC 12V (10mA).

The air conditioning charges calculations of this unit are based on OIML, the international standard.

* In case embodying in a wall, please be sure to special box SLA3R-BX (option).



<PC windows central control>

SC-WGWNA-A/SC-WGWNA-B Production by order

(SC-WGWNA-B is with electric power calculation function)

Control and monitoring of up to 96 cells (some cells can have two or more indoor units and total number of indoor units can be up to 128 units) centralised to a network PC using the Superlink-II web gateway. Simple installation is assured with no special software requirements, operation is via Internet Explorer. A low power embedded CPU and compact flash ROM ensure a large storage capacity with high reliability (no moving parts such as a PC fan, etc). An IP address filter function combined with three-level user authentication check also ensures security.



Additional engineering service cost etc. is required. Please consult your dealer when using this central control.

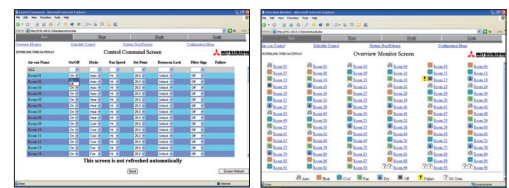
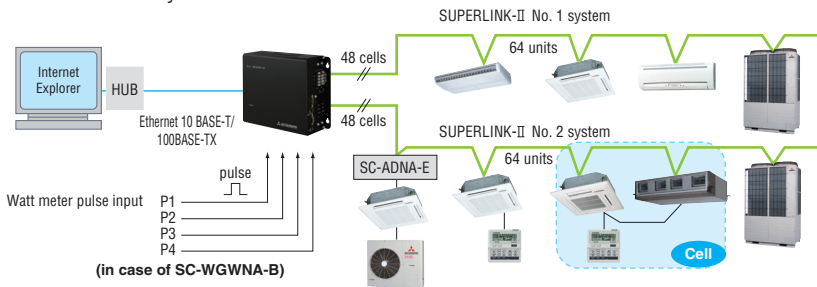

PC requirements: Windows 2000 or Windows XP or Windows Vista.
Monitor resolution 1024 x 768.
Web browser requirements: Internet Explorer 6.0 or 7.0.

<BMS interface unit>

SC-BGWNA-A/SC-BGWNA-B (BACnet gateway) Production by order

(SC-BGWNA-B is with electric power calculation function)

SC-BGWNA-A/B is an interface device that converts MHI's Superlink-II communication data to BACnet code. Control and monitoring functions of the a/c system for up to 96 cells (some cells can have two or more indoor units and total number of indoor units can be up to 128 units) can be integrated to a central control point via the building management system network.



Additional engineering service cost etc. is required. In case of SC-BGWNA-B, communication test by qualified person regarding electric cost calculation function is required before commissioning. Please consult your dealer when using this gateway.

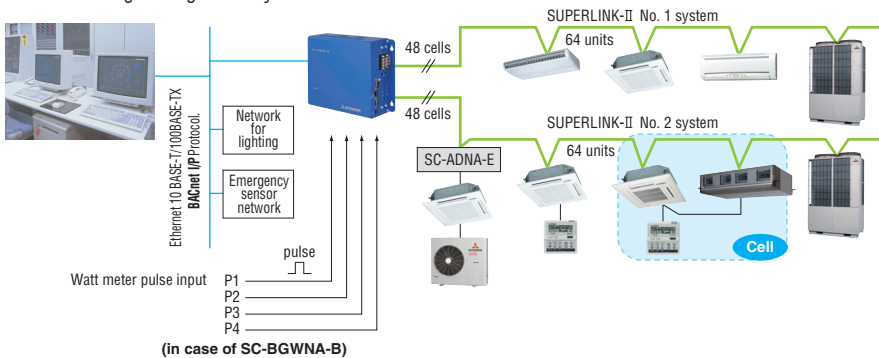

SC-LGWNA-A (LonWorks gateway) Production by order

SC-LGWNA-A is an interface device that converts MHI's Superlink-II communication data to LonWorks code. Control and monitoring functions of the a/c system for up to 96 indoor units can be integrated to a central control point via the building management system network.



Additional engineering service cost etc. is required. Please consult your dealer when using this gateway.

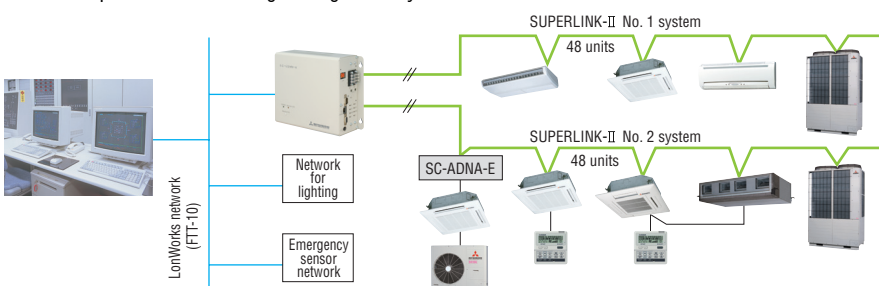



KX6 Outdoor units

High Head series (90m)

14~48hp (40.0~136.0kW)

NEW

Production by order

Model No.	Nominal Cooling Capacity
FDCH335KXE6-K ^{**}	33.5 kW
FDCH400KXE6	40.0 kW
FDCH450KXE6	45.0 kW
FDCH504KXE6	50.4 kW
FDCH560KXE6	56.0 kW
FDCH560KXE6-K ^{**}	56.0 kW
FDCH615KXE6	61.5 kW
FDCH680KXE6	68.0 kW

^{**} FDCH335KXE6-K & FDCH560KXE6-K are only used for combining with other models.

- Maximum allowable height difference between the outdoor and the indoor unit located at the lowest height position has been increased from 50m to 90m.
(When the outdoor unit is located at higher position than the indoor unit)

Model No.	Nominal Cooling Capacity
FDCH735KXE6 (FDCH335-K+FDCH400)	73.5 kW
FDCH800KXE6 (FDCH400x2)	80.0 kW
FDCH850KXE6 (FDCH400+FDCH450)	85.0 kW
FDCH900KXE6 (FDCH450x2)	90.0 kW
FDCH960KXE6 (FDCH450+FDCH504)	96.0 kW
FDCH1010KXE6 (FDCH504x2)	101.0 kW
FDCH1065KXE6 (FDCH504+FDCH560)	106.5 kW
FDCH1130KXE6 (FDCH560x2)	113.0 kW
FDCH1180KXE6 (FDCH560-K+FDCH615)	118.0 kW
FDCH1235KXE6 (FDCH615x2)	123.5 kW
FDCH1300KXE6 (FDCH615+FDCH680)	130.0 kW
FDCH1360KXE6 (FDCH680x2)	136.0 kW



FDCH335KXE6-K
FDCH400KXE6
FDCH450KXE6



FDCH504-680KXE6

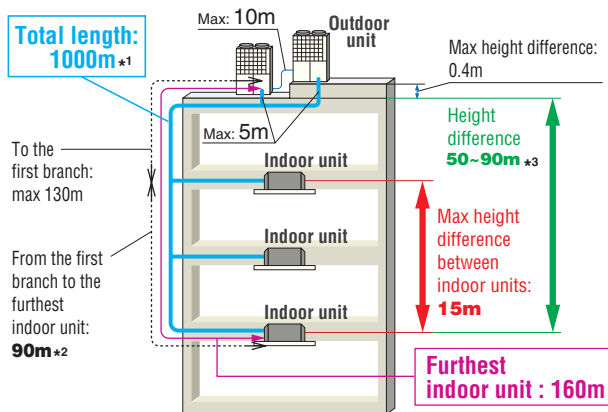

*1 Select the total pipe length depending on the connectable capacity of indoor units.

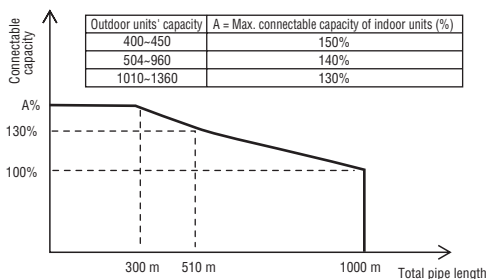

Range of operation

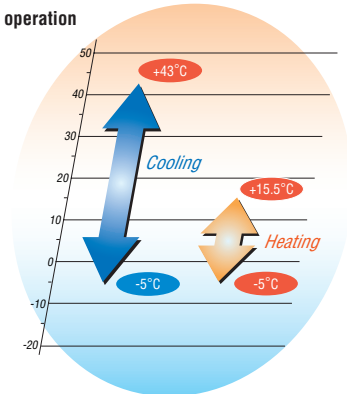

*2 The difference between the longest and shortest indoor unit piping from the first branch must be within 40m.

*3 In case of less than 50m, the High Head models can not be applied. In case Indoor unit is higher than outdoor unit, the High Head models can not be applied.

Specifications

Item	Model	FDCH400KXE6	FDCH450KXE6	FDCH504KXE6	FDCH560KXE6	FDCH615KXE6	FDCH680KXE6	
Nominal horse power		14HP	16HP	18HP	20HP	22HP	24HP	
Power source		3 Phase 380-415V, 50Hz						
Nominal capacity	Cooling	kW	40.0	45.0	50.4	56.0	61.5	
	Heating	kW	45.0	50.0	56.5	63.0	69.0	
Electrical characteristics	Starting current		A					8
	Power consumption	Cooling	kW	11.27	12.97	14.73	16.79	20.37
		Heating	kW	11.73	13.10	15.12	16.79	18.48
	Running current	Cooling	A	18.4-16.9	21.1-19.3	24.1-22.0	27.4-25.1	33.1-30.3
		Heating	A	19.6-17.9	21.7-19.9	25.2-23.1	28.0-25.7	30.7-28.1
Exterior dimensions	HxWxD	mm	1690x1350x720			2048x1350x720		
Net weight		kg	319		343		357	
Refrigerant charge	R410A	kg	11.5					
Sound pressure level	Cooling / Heating	dB(A)	59.5 / 59.5	62.5 / 62.5	61.5 / 61.5	63.0 / 63.0	64.5 / 64.5	
Refrigerant piping size	Liquid line	mm(in)	ø12.7(1/2")			ø15.88(5/8")		
	Gas line	mm(in)	ø25.4(1") [ø28.58(1 1/8")]		ø28.58(1 1/8")			
Capacity connection		%	not fixed					
Number of connectable indoor units			36	40	36	40	44	

Item	Model	FDCH735KXE6	FDCH800KXE6	FDCH850KXE6	FDCH900KXE6	
Combination (FDCH)		335KXE6-K	400KXE6	400KXE6	450KXE6	
Nominal horse power		26HP	28HP	30HP	32HP	
Power source		3 Phase 380-415V, 50Hz				
Nominal capacity	Cooling	kW	73.5	80.0	85.0	
	Heating	kW	82.5	90.0	95.0	
Electrical characteristics	Starting current		A			16
	Power consumption	Cooling	kW	20.21	22.54	24.24
		Heating	kW	20.66	23.46	24.83
	Running current	Cooling	A	32.9-30.2	36.8-33.8	39.5-36.2
		Heating	A	34.4-31.4	39.2-35.8	41.3-37.8
Exterior dimensions	HxWxD	mm	1690x2700x720			
Net weight		kg	319x2			
Refrigerant charge	R410A	kg	11.5x2			
Refrigerant piping size	Liquid line	mm(in)	ø19.05(3/4")			
	Gas line	mm(in)	ø31.8(1 1/4") [ø34.92(1 3/8")]			
Capacity connection		%	not fixed			
Number of connectable indoor units			53	58	61	

Item	Model	FDCH960KXE6	FDCH1010KXE6	FDCH1065KXE6	FDCH1130KXE6	
Combination (FDCH)		450KXE6	504KXE6	504KXE6	560KXE6	
Nominal horse power		34HP	36HP	38HP	40HP	
Power source		3 Phase 380-415V, 50Hz				
Nominal capacity	Cooling	kW	96.0	101.0	106.5	
	Heating	kW	108.0	113.0	119.5	
Electrical characteristics	Starting current		A			16
	Power consumption	Cooling	kW	27.70	29.46	31.52
		Heating	kW	28.22	30.24	31.91
	Running current	Cooling	A	45.2-41.3	48.2-44.0	51.5-47.1
		Heating	A	46.9-43.0	50.4-46.2	53.2-48.8
Exterior dimensions	HxWxD	mm	2048x2700x720			
Net weight		kg	319+343	343x2		
Refrigerant charge	R410A	kg	11.5x2			
Refrigerant piping size	Liquid line	mm(in)	ø19.05(3/4")		ø22.22(7/8")	
	Gas line	mm(in)	ø31.8(1 1/4") [ø34.92(1 3/8")]			
Capacity connection		%	not fixed			
Number of connectable indoor units			69	59	62	

Item	Model	FDCH1180KXE6	FDCH1235KXE6	FDCH1300KXE6	FDCH1360KXE6	
Combination (FDCH)		560KXE6-K	615KXE6	615KXE6	680KXE6	
Nominal horse power		42HP	44HP	46HP	48HP	
Power source		3 Phase 380-415V, 50Hz				
Nominal capacity	Cooling	kW	118.0	123.5	130.0	
	Heating	kW	132.0	138.0	142.0	
Electrical characteristics	Starting current		A			16
	Power consumption	Cooling	kW	37.16	40.74	45.35
		Heating	kW	35.27	36.96	37.56
	Running current	Cooling	A	60.5-55.4	66.2-60.6	73.4-67.2
		Heating	A	58.7-53.8	61.4-56.2	62.3-57.1
Exterior dimensions	HxWxD	mm	2048x2700x720			
Net weight		kg	357x2			
Refrigerant charge	R410A	kg	11.5x2			
Refrigerant piping size	Liquid line	mm(in)	ø22.22(7/8")			
	Gas line	mm(in)	ø38.1(1 1/2")			
Capacity connection		%	not fixed			
Number of connectable indoor units			69	72	76	

1. The data are measured under the following conditions (ISO-T1). Cooling: Indoor temp. of 27°CDB, 19°CWB, and outdoor temp. of 35°CDB. Heating: Indoor temp. of 20°CDB, and outdoor temp. of 7°CDB, 6°CWB. Piping length is 7.5m.
 2. Sound pressure level indicates the value in an anechoic chamber. During operation these values are somewhat higher due to ambient conditions.
 3. [] : Pipe sizes applicable to European installations are shown in parentheses.



Dimensions

All measurements in mm.

FDCH335KXE6-K, 400KXE6, 450KXE6

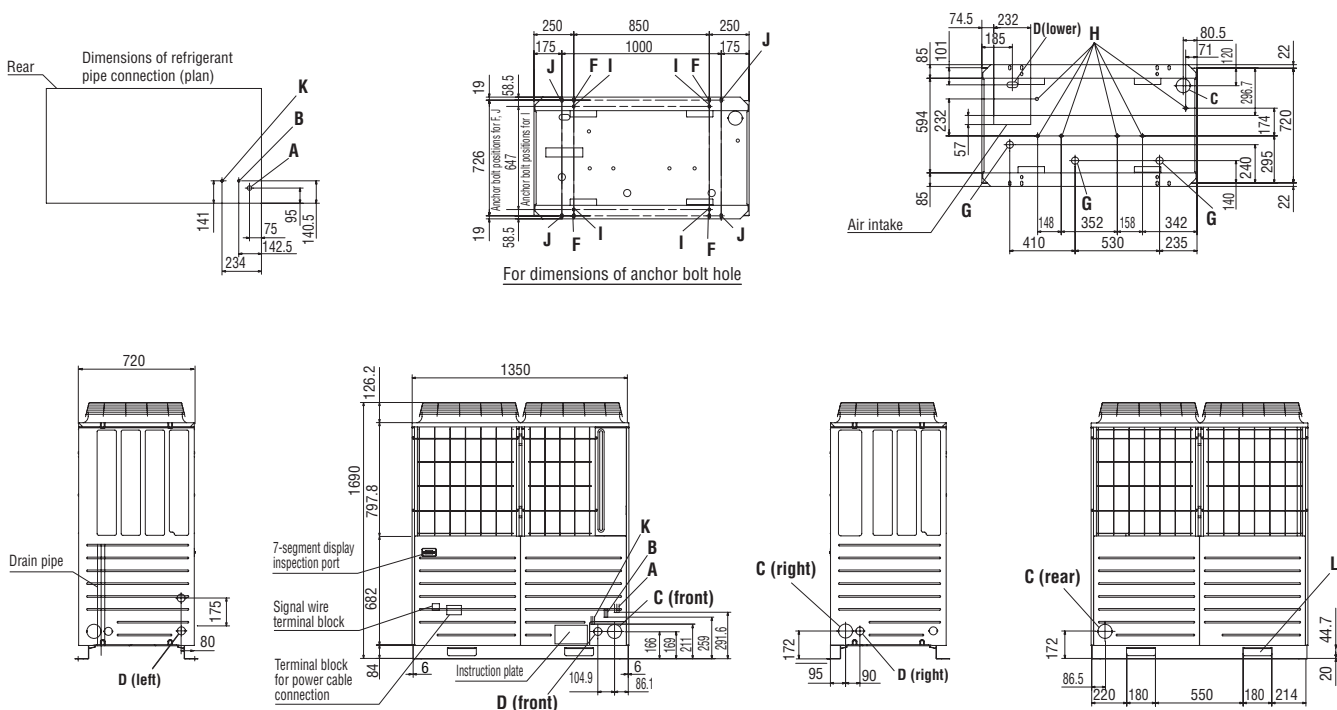

Mark	Item	
A	Service valve connection (gas side)	For refrigerant piping, please refer to the unit specifications.
B	Service valve connection (liquid line)	
C	Refrigerant pipe draw-out port	ø88
D	Power cable draw-in port	ø50
F	Anchor bolt hole	M10 x 4 places
G	Drain hose hole	ø45 x 3 places
H	Drain discharge port	ø20 x 6 places
K	Oil-equalising pipe joint	ø3/8" flare
L	Sling holes for haulage or hoisting	180 x 44.7

Installation example		
Dimensions	1	2
L1	500	Open
L2	10	200
L3	100	300
L4	10	Open
H1	1500	-
H2	No restrictions	No restrictions
H3	1000	No restrictions
H4	No restrictions	-

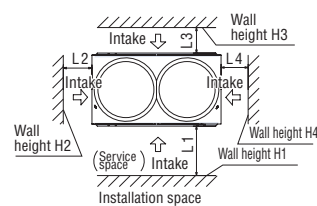

2m overhead clearance required

*14, 16HP models only

Notes:

- The unit must be fixed with anchor bolts.
- Leave a 2m or larger space above the unit.
- The unit name plate is attached on the lower right corner of the front panel.
- The ports for refrigerant pipe and power cable penetrations are covered with half-blanks. Please cut off a half-blank with nippers in using these ports.
- Use a ø88 port for refrigerant pipe connection.
- Anchor holes marked "L J" (four holes for M10) are for a renewal installation.
- The oil-equalising pipe K should be used when outdoor units are used in combination. (For 14,16Hp only)

When more than one unit is installed

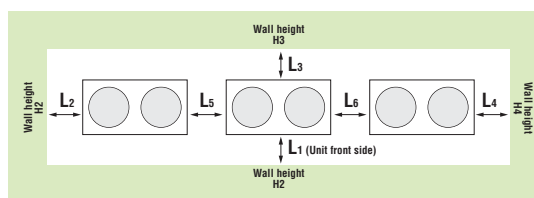

Installation example		
Dimensions	A	B
L1	500	Open
L2	10	200
L3	100	300
L4	10	Open
L5	0	400
L6	0	400
H1	1500	No restrictions
H2	No restrictions	No restrictions
H3	1000	No restrictions
H4	No restrictions	No restrictions

Dimensions

All measurements in mm.

FDCH504KXE6, 560KXE6, 560KXE6-K, 615KXE6, 680KXE6

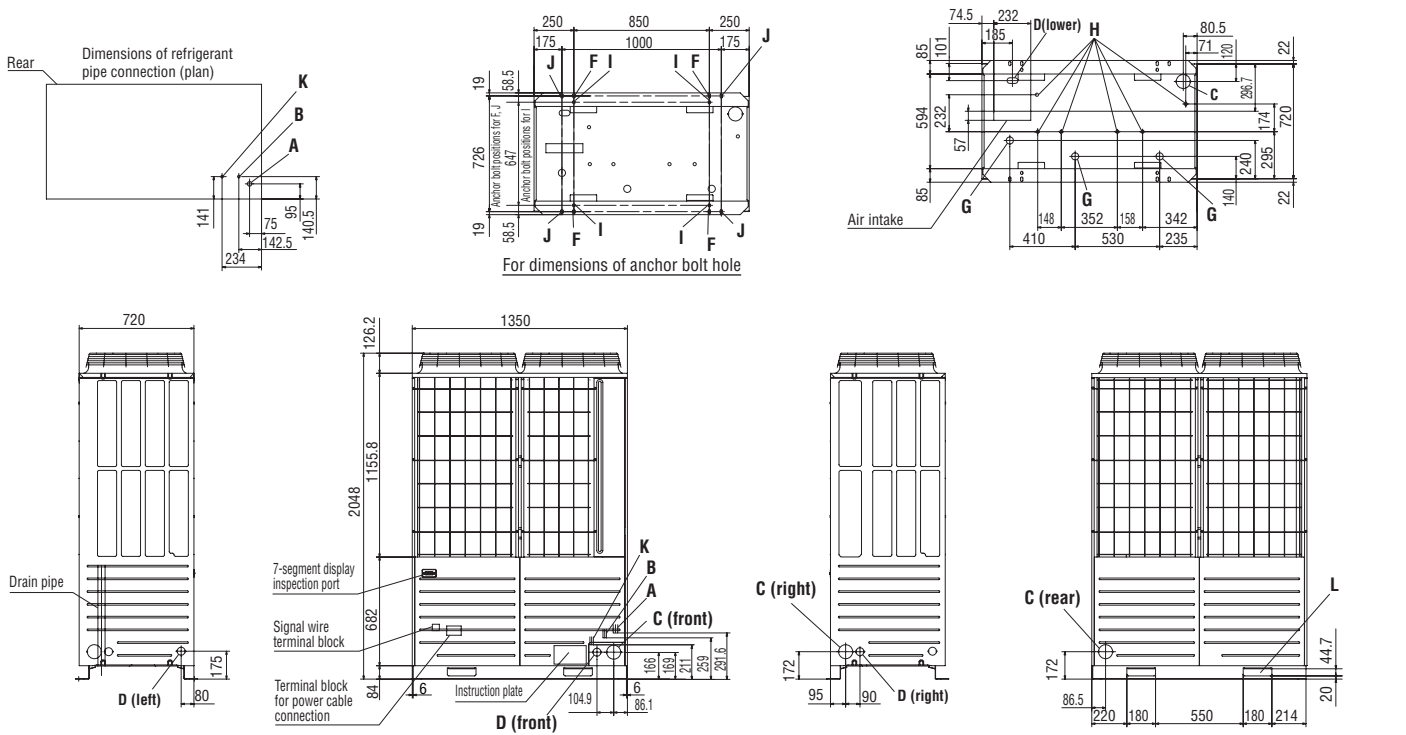

Mark	Item	
A	Service valve connection (gas side)	
B	Service valve connection (liquid line)	For refrigerant piping, please refer to the unit specifications.
C	Refrigerant pipe draw-out port	ø100
D	Power cable draw-in port	ø50
F	Anchor bolt hole	M10 x 4 places
G	Drain hose hole	ø45 x 3 places
H	Drain discharge port	ø20 x 6 places
K	Oil-equalising pipe joint	ø9.52 flare
L	Sling holes for haulage or hoisting	180 x 44.7

Installation example		
Dimensions	1	2
L ₁	500	Open
L ₂	10	200
L ₃	100	300
L ₄	10	Open
H ₁	1500	-
H ₂	No restrictions	No restrictions
H ₃	1000	No restrictions
H ₄	No restrictions	-

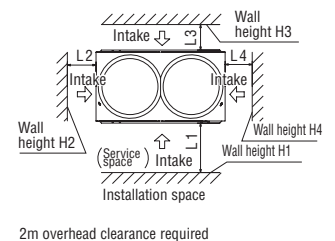

Notes:

- (1) The unit must be fixed with anchor bolts.
- (2) Leave a 2m or larger space above the unit.
- (3) The unit name plate is attached on the lower right corner of the front panel.
- (4) The ports for refrigerant pipe and power cable penetrations are covered with half-blanks. Please cut off a half-blank with nippers in using these ports.
- (5) Use a ø88 port for refrigerant pipe connection.
- (6) Anchor holes marked "L J" (four holes for M10) are for a renewal installation.
- (7) The oil-equalising pipe K should be used when outdoor units are used in combination.



KX4 Outdoor units

Heat pump systems 8, 10, 12hp (22.4kW~33.5kW)

Production by order

Model No.	Nominal Cooling Capacity
FDCA224HKXE4D	22.4kW
FDCA280HKXE4D	28.0kW
FDCA335HKXE4D	33.5kW

- Superlink models (not Superlink-II models)
- The KX4 heat pump 2-pipe systems offer high performance VRF for applications that require either cooling only or heating only.
- Connect up to 20 indoor units/up to 130% capacity.
- High efficiency with COP (in cooling) from 3.6 to 3.9.



Uniform footprint of all models allows continuous side-by-side installation

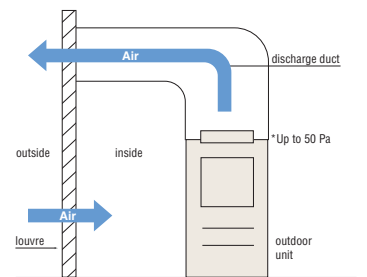
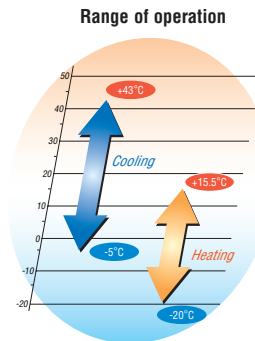
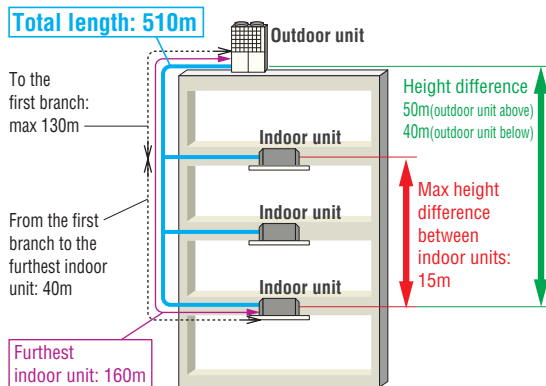

In case an outdoor unit is installed inside the building and outdoor exhaust air is discharged to outside the building through duct system, these units have necessary minimum external static pressure (50Pa).

Specifications

Item	Model	FDCA224HKXE4D	FDCA280HKXE4D	FDCA335HKXE4D	
Nominal horse power		8HP	10HP	12HP	
Power source		3 Phase 380V-415V, 50Hz			
Nominal capacity	Cooling	22.4	28.0	33.5	
	Heating	25.0	31.5	37.5	
Electrical characteristics	Starting current	A			
	Power consumption	Cooling	5.70	8.26	9.53
		Heating	5.98	8.06	9.84
	Operating current	Cooling	9.6-8.8	13.6-12.4	15.5-14.2
Heating		9.6-8.8	13.3-12.4	16.3-14.9	
Exterior dimensions	HxWxD	mm			
Net weight		kg			
Refrigerant charge	R410A	kg			
Sound pressure level	Cooling/Heating	dB(A)			
Refrigerant piping size	Liquid line	mm(in)			
	Gas line	mm(in)			
Capacity control	%	27~126	20~114	19~117	
Number of connectable indoor units		13	16	20	

1. The data are measured under the following conditions(ISO-T1). Cooling: Indoor temp. of 27°CDB, 19°CWB, and outdoor temp. of 35°CDB. Heating: Indoor temp. of 20°CDB, and outdoor temp. of 7°CDB, 6°CWB.
 2. Sound pressure level indicates the value in an anechoic chamber. During operation these values are somewhat higher due to ambient conditions.

Dimensions

All measurements in mm.

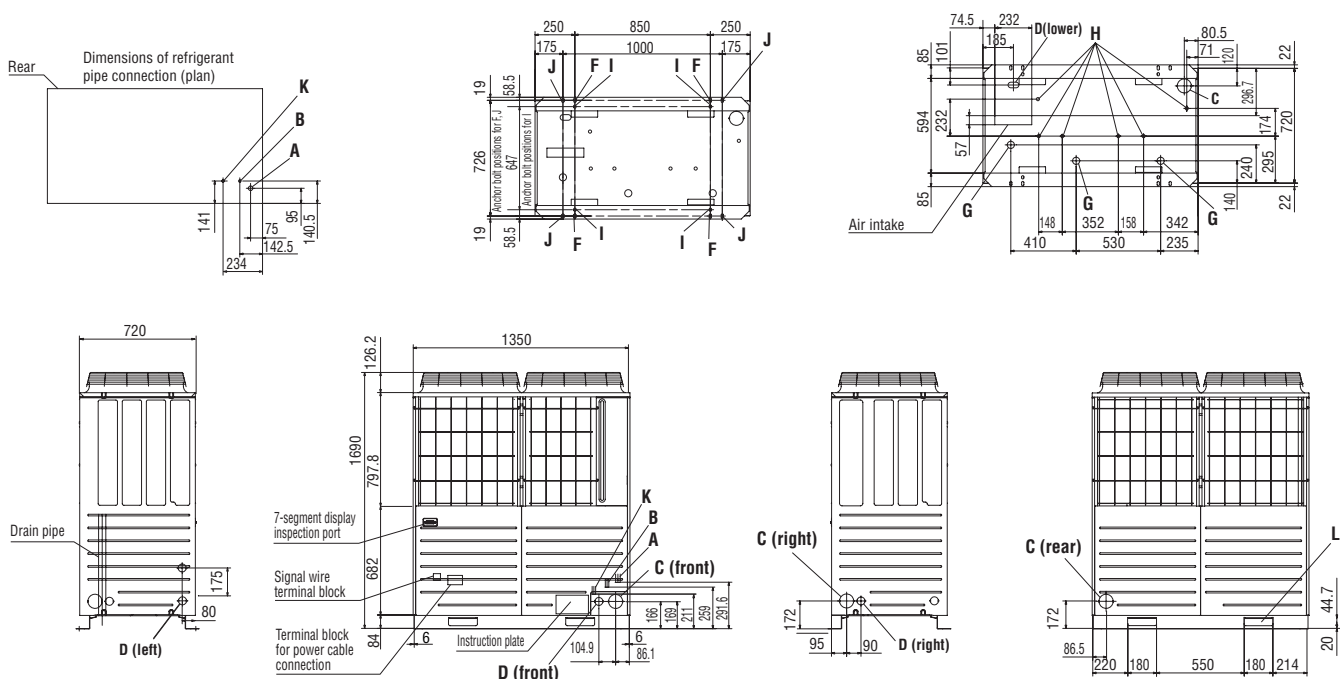

Mark	Item	
A	Service valve connection (gas side)	For refrigerant piping, please refer to the unit specifications.
B	Service valve connection (liquid line)	
C	Refrigerant pipe draw-out port	ø88
D	Power cable draw-in port	ø50
F	Anchor bolt hole	M10 x 4 places
G	Drain hose hole	ø45 x 3 places
H	Drain discharge port	ø20 x 6 places
K*	Oil-equalising pipe joint	ø3/8" flare
L	Sling holes for haulage or hoisting	180 x 44.7

*14 + 16HP models only

Installation example		
Dimensions	1	2
L ₁	500	Open
L ₂	10	200
L ₃	100	300
L ₄	10	Open
H ₁	1500	-
H ₂	No restrictions	No restrictions
H ₃	1000	No restrictions
H ₄	No restrictions	-

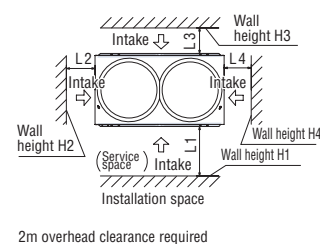

Notes:

- The unit must be fixed with anchor bolts.
- Leave a 2m or larger space above the unit.
- The unit name plate is attached on the lower right corner of the front panel.
- The ports for refrigerant pipe and power cable penetrations are covered with half-blanks. Please cut off a half-blank with nippers in using these ports.
- Use a ø88 port for refrigerant pipe connection.
- Anchor holes marked "L J" (four holes for M10) are for a renewal installation.

When more than one unit is installed

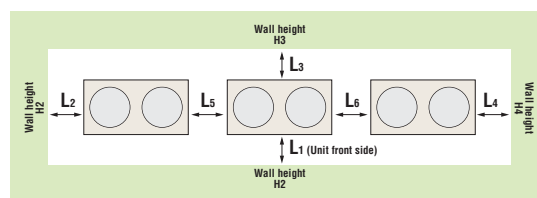

Installation example		
Dimensions	A	B
L ₁	500	Open
L ₂	10	200
L ₃	100	300
L ₄	10	Open
L ₅	0	400
L ₆	0	400
H ₁	1500	No restrictions
H ₂	No restrictions	No restrictions
H ₃	1000	No restrictions
H ₄	No restrictions	No restrictions



Mitsubishi Heavy Industries **KX6**/further information

Mitsubishi Heavy Industries operates a continuous CSR (Corporate Social Responsibility) policy, with a role to realise a sustainable society through it's various areas of business.

Creed

- We strongly believe that the customer comes first and that we are obliged to be an innovative partner to society.
- We base our activities on honesty, harmony, and a clear distinction between public and private life.
- We shall strive for innovative management and technological development from an international perspective.

Reason for Instituting the Creed

In Japan there are many enterprises with their own "creeds" which simply represent their management concept.

Mitsubishi Heavy Industries, Ltd. has a creed of this type, also. It was instituted in 1970 on the basis of the policy advocated by Koyata Iwasaki, president of Mitsubishi Goshi Kaisha in the 1920's, to indicate the essential attitude of the company, the mental attitude of the employees, and the future directions of the company.

The reason for instituting the present creed is so that all of us can call to mind our one hundred years of tradition, and strive for further development in the future.

Issued 1 June 1970

MHI's creed was established based on "The Three Corporate Principles" shared by the Mitsubishi Group from the company's beginnings. In the spirit of this creed, MHI continues its efforts to fulfil its three corporate social responsibilities (CSRs): "corporate governance and compliance," "the environment, human rights and labour," and "contribution to society through business activities."

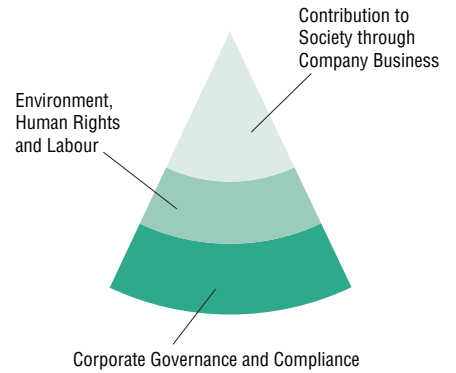

Contribution to Society through Company Business

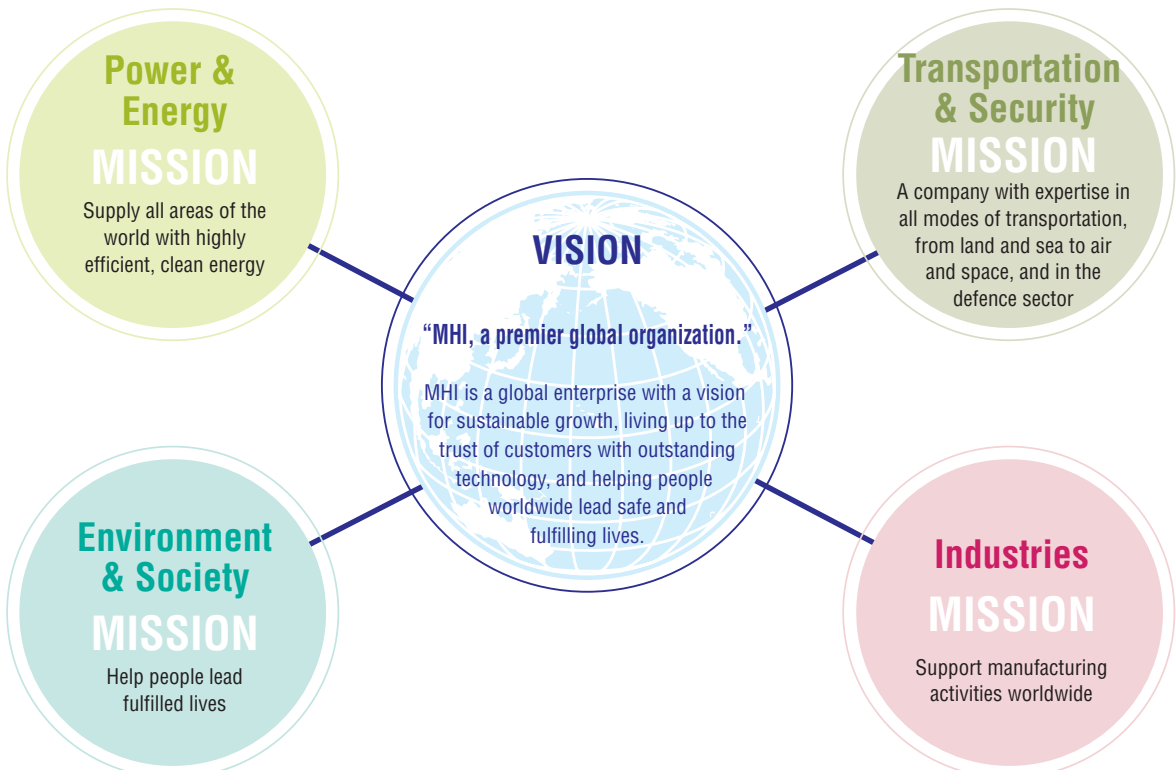

The KX6 product range has been developed in compliance with the Mitsubishi Heavy Industries Policy on the Environment.

In order to make the sustainable development of society possible, a basic policy on environmental matters has been established.

Pursuant to the express provision of Section 1 of its creed that “We strongly believe that customers come first and that we are obligated to be an innovative partner to society,” MHI shall, as a matter of primary importance, strive, through its R&D, manufacturing and other business activities, to play a useful role in the development of society. To this end, while remaining aware that a business enterprise is a member of society, MHI shall endeavour, in all aspects of its business activities, to reduce the burden on the environment and shall concentrate and fully utilise its technological capabilities for the development of technologies and products that will protect the environment, thus contributing to the establishment of a society in which sustainable development is possible.

In order to realise its basic policy, MHI has set the following seven conduct guidelines.

1. Recognise that environmental protection is top priority in the company’s operations, and encourage the entire company in its endeavours to protect and improve the environment.
2. Define roles and responsibilities regarding environmental protection by developing and maintaining a corporate organisation designated for environmental protection, and create and implement corporate policies and procedures on environmental matters.
3. Endeavour to reduce the burden on the environment by preventing pollution, saving resources, saving energy, reducing waste, reusing materials, and recycling in all aspects of the company’s business activities in R&D, designing, procurement of materials, manufacturing, transportation, use, service and disposal.
4. Endeavour to develop and provide advanced, highly reliable, unique technologies and products that contribute to solving environmental and energy problems.
5. Comply with national and local environmental laws and regulations, beyond mere compliance by enacting, implementing and evaluating voluntary standards where necessary, and to endeavour to continuously improve and promote environmental protection activities by establishing environmental goals and targets.
6. Endeavour to protect the environments of foreign countries by carefully examining the consequences of the company’s overseas business operations and the exportation of its products, and to become actively involved in technological co-operation overseas in areas of environmental protection.
7. Provide environmental training and other programs to enhance the environmental awareness of all company employees, and take steps to expand public relations activities, such as providing environment-related information to the public and social contribution activities.

Number of offices/plants by region (Consolidated) as of June, 2010

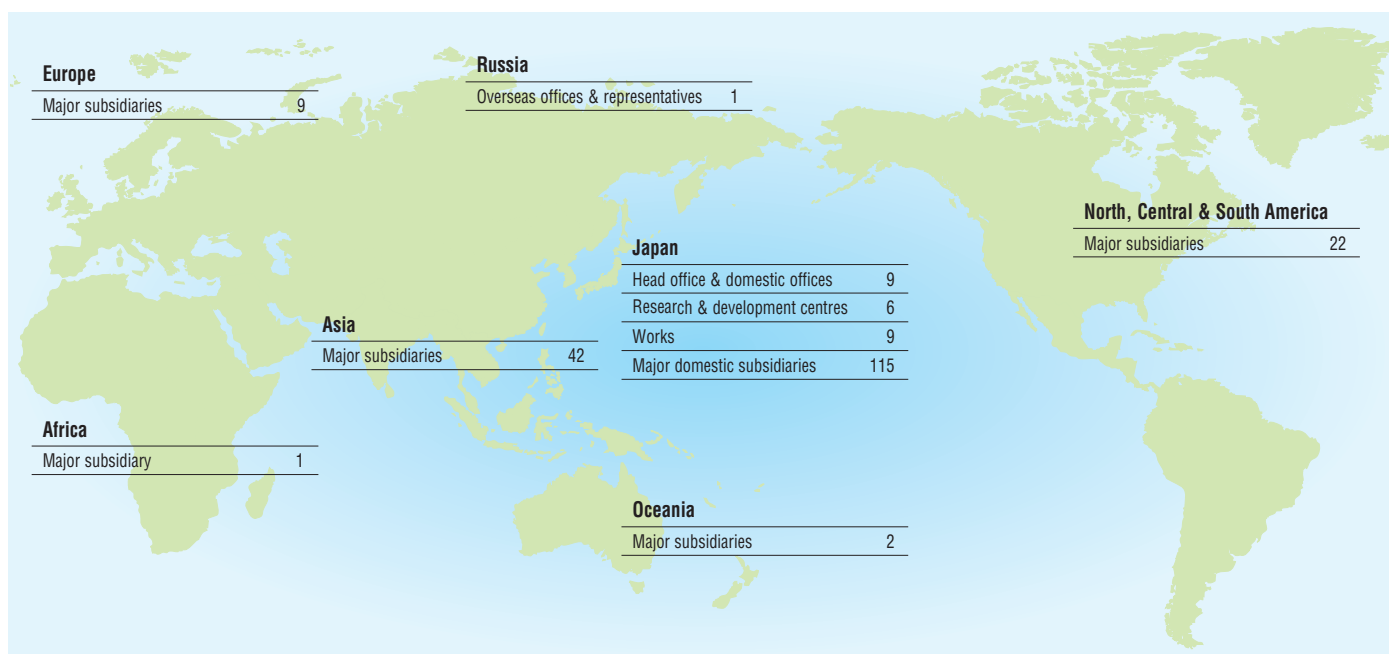

On the land and sea, in the sky and even in space, MHI's stage of operations is expanding limitlessly. We manufacture more than 700 different products which support various industrial and civil activities in both domestic and international markets.

Ships, steel structures, power systems, machinery for both industrial and general use, air-conditioners, pollution reduction and environmental control systems, aerospace systems – the MHI product lines which create rich and comfortable living environments, are as harmonious as an orchestra.

What creates this harmony is MHI's general technological expertise developed over more than a century of hard work. We are highly esteemed in the world for providing high

quality products through untiring technological research and development. From new energy development and environmental concerns to the exploration of space, with the advent of the 21st century MHI is confronting a variety of issues to ensure the realisation of a society in which there is harmony between mankind and technology.



- Crude Oil Storage Barges
- LNG Tanks
- Boilers & Turbines
- Oil Production Plants
- Contra-Rotating Propellers
- Thermal Power Plants
- Combined Cycle Plants
- Fuel Cells
- Water Turbines
- Wind Turbines
- Geothermal Power Plants
- PWR Nuclear Power Plants
- Uranium Enrichment Equipment
- FBRs
- Co-Generation Systems



- Ultra-High Steel Stacks
- Refuse Incineration Plants
- Night Soil Treatment Plants
- Electrostatic Precipitators
- Flue Gas Desulfurization System
- Fluidized Incinerators
- CFC Collecting Equipment



- Spillway Radial Gates
- Steel Bridges
- Penstocks
- Desalination Plants
- Physical Distribution Equipment
- Engines



- Unloader & Container Cranes
- Mechanical Parking Facilities
- Integrated Automated Storage Systems
- Rubber & Tyre Machinery
- Skyrails
- Monorail Cars
- New Transportation Systems
- Passenger Boarding Bridges

- Toll Collection Machine Systems
- Forklift Trucks
- Helicopters
- Aircraft
- Railway Maintenance Equipment
- LNG Carrier
- Container Ships



TRANSPORTATION
LOCAL DEVELOPMENT
ENVIRONMENT
RESOURCES/ENERGY

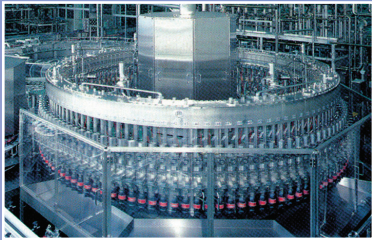

- Chemical Plants
- Wind Tunnel/Experiment Equipment
- Casting Machines
- Strip Mill
- Cement Plant
- Stepless Variable Speed Gears
- Industrial Robots
- Injection Moulding Machines
- Pulp & Paper Machinery
- Corrugation Machines
- Box Making Machines
- Machine Tools



- Ceiling Recess Packaged Air Conditioners
- Automotive Air Conditioners
- Residential Use Split Air Conditioners
- Refrigeration Units
- Dry Cleaning Machines
- Food Machinery
- Cruise Ships
- Multi-purpose Dome
- Stage Machinery Systems



- Cable Layer
- Printing Machinery



- Oceanographic Research Ships
- Deep Submergence Research Vehicles
- Communications Satellite Rockets
- Space Transportation
- Rockets & Engines



INDUSTRIAL

LEISURE/LIFESTYLE

INFORMATION SYSTEM

DEVELOPMENT

DEFENCE



- Submarines
- Naval Vessels
- Jet Fighters
- Helicopters
- Missiles
- Tanks & Infantry Fighting Vehicles

Before starting use

Heating performance

The heating performance values (kW) described in catalog are the values obtained by operating at an outdoor temperature of 7°C and indoor temperature of 20°C as set forth in the ISO Standards. As the heating performance decreases as the outdoor temperature drops, if the outdoor temperature is too low and the heating performance is insufficient, use other heating appliances as well.

Indication of sound values

The sound values are the values (A scale) measured in a chamber such as an anechoic chamber following the ISO Standards. In the actual installation state, the value is normally larger than the values given in the catalog due to the effect of surrounding noise and echo. Take this into consideration when installing.

Use in oil atmosphere

Avoid installing this unit in as atmosphere where oil scatters or builds up, such as in a kitchen or machine factory. If the oil adheres to the heat exchanger, the heat exchanging performance will drop, mist may be generated, and the synthetic resin parts may deform and break.

Use in acidic or alkaline atmosphere

If this unit is used in acidic atmosphere such as hot spring areas having high level of sulfuric gases or in alkaline atmosphere including ammonia or calcium chloride, places where the exhaust of the heat exchanger is sucked in, or at coastal areas where the unit is subject to salt breezes, the outer plate or heat exchanger, etc., will corrode. Please ask a dealer or specialist when you use an air conditioner in places differing from a general atmosphere.

Use in places with high ceilings

If the ceiling is high, install a circulator to improve the heat and air flow distribution when heating.

Refrigerant leakage

The refrigerant (R410A) used for Air conditioner is non-toxic and inflammable in its original state. However, in consideration of a state where the refrigerant leaks into the room, measures against refrigerant leaks must be taken in small rooms where the tolerable level could be exceeded. Take measures by installing ventilation devices, etc.

Use in snowy areas

Take the following measures when installing the outdoor unit in snowy areas.

•Snow prevention

Install a snow-prevention hood so that the snow does not obstruct the air intake port or enter and freeze in the outdoor unit.

•Snow piling

In areas with heavy snow fall, the piled snow could block the air intake port. In this case, a frame that is 50cm or higher than the estimated snow fall must be installed underneath the outdoor unit.

Automatic defrosting device

If the temperature is low, and the humidity is high, frost will stick to the heat exchanger of the outdoor unit. If use is continued, the heating performance will drop.

The "Automatic defrosting device" will function to remove this frost.

After heating for approx, three to ten minutes, it will stop, and the frost will be removed. After defrosting, hot air will be blown again.

Servicing the air-conditioner

After the air-conditioner is used for several seasons, dirt will build up in the air-conditioner causing the performance to drop. In addition to regular servicing, we recommend the maintenance contract (charged for) by a specialist.

⚠ Safety Precautions

Air-conditioner usage target

The air-conditioner described in this catalog is a dedicated cooling/heating device for human use.

Do not use it for special applications such as the storage of foodstuffs, animals or plants, precision devices or valuable art, etc.

This could cause the quality of the items to drop, etc.

Do not use this for cooling vehicles or ships. Water leakage or current leaks could occur.

Before use

Always read the "User's Manual" thoroughly before starting use.

Installation

Always commission the installation to a dealer or specialist. Improper installation will lead to water leakage, electric shocks and fires.

Make sure that the outdoor unit is stable in installation. Fix the unit to stable base.

Usage place

Do not install in places where combustible gas could leak or where there are sparks.

Installation in a place where combustible gas could be generated, flow or accumulate, or places containing carbon fibers could lead to fires.



Japan Head Office:

Mitsubishi Heavy Industries Ltd
16-5 2-Chome Kounan Minato-ku Tokyo
108-8215, Japan
www.mhi.co.jp

Our factories are ISO9001 and ISO14001 certified.

Certified ISO 9001



BIWAJIMA PLANT
Mitsubishi Heavy Industries, Ltd.
Air-conditioning & Refrigeration Systems Headquarters



MITSUBISHI HEAVY INDUSTRIES-
MAHAJAK AIR CONDITIONERS CO., LTD.



Mitsubishi Heavy
Industries-Haier (Dungdao)
Air-conditioners Co., Ltd.

Certified ISO 14001



BIWAJIMA PLANT
Mitsubishi Heavy Industries, Ltd.
Air-conditioning & Refrigeration Systems Headquarters



MITSUBISHI HEAVY INDUSTRIES-
MAHAJAK AIR CONDITIONERS CO., LTD.



Mitsubishi Heavy
Industries-Haier (Dungdao)
Air-conditioners Co., Ltd.

